

# Data sheet for three-phase Squirrel-Cage-Motors SIMOTICS

Motor type: **SD100 IEEE** FS: **444TS - 2p - 125 hp -**

Client order no.	Item-No.	Offer no.
Order no.	Consignment no.	Project
Remarks		

## Electrical data

Class I Division 2 Gr. A, B, C or D, T3

U [V]	$\Delta / Y$	f [Hz]	P [HP]	P [kW]	n [rpm]	I Load [Amps]					LRC	Nom. Eff Load [%]			Pwr. Factor Load [%]			Torque [lb-ft]	T <sub>A</sub> /T <sub>N</sub> LRT [%]	T <sub>k</sub> /T <sub>N</sub> BDT [%]
						4/4	3/4	1/2	0	4/4		3/4	2/4	4/4	3/4	2/4				
575	$\Delta$	60	125.00	90.00	3,600	112.00	83.90	59.00	29.60	726.4	95.0	95.1	94.5	89.0	88.0	84.0	184.0	110	200	
Frame Type: 444TS		Type of constr.: (A) Foot mounted - End shield				Ins. Cl.: Standard Class F Insulation		Motor Prot.: (A) Without Protection			NEMA Des.: B		S.F.: 1.15							
Mtr. WT: 0						Temp. Rise Cl.: B		Amb. Temp.: + 40 to -20 °C @1000 m			kVA: G		IP 55							

## Mechanical data

Sound level (SPL / SWL) at 60 Hz	73.0 dB(A) / 84.0 dB(A)							Thickener	Polyurea
Octave Band Center Frequencies Hertz									
	250	500	1000	2000	4000	8000	Hz	Safe Stall Time Hot	18 s
SPL@3	56.0	59.0	63.0	65.0	56.0	50.0	dB(A)	Safe Stall Time Cold	23 s
Moment of inertia	0.0 Lb-ft <sup>2</sup>							Frame material	cast iron
Ext Load Inertia Capability:	113.0 Lb ft <sup>2</sup>							Color, paint shade	Standard Paint - RAL7030
<b>Bearings</b>								Coating (paint finish)	Standard Alkyed + Epoxy (C2)
Bearing DE   NDE	6318 Z C3 S0			6316 Z C3 S0			<b>Ventilation Type</b>		
Bearing_Type	Ball Bearing			Ball Bearing			Method of cooling	TEFC	
AFBMA:	90BC03JP30			80BC03JP30			Direction of rotation	Bidirectional	
<b>Grease</b>								Fan Material	Polypropylen ESD
Capacity	7.5 oz			7.5 oz			VFD	CT: 4:1 VT: 20:1	
Grease Type:	Exxon Mobile EM							Space heaters	without
								Brake:	without

## Terminal box

Lead Wire Connection					Terminal box position	(3) F-1, Standard Floor Mount, T. Box LHS
Voltage	L1	L1	L1	Connected together	Material of terminal box	Cast Iron
----	----	----	----	----	Cable entry	3" NPT
----	T1	T2	T3	----		

### Notes:

I<sub>L</sub>/I<sub>N</sub> = locked rotor current / current nominal  
M<sub>L</sub>/M<sub>N</sub> = locked rotor torque / torque nominal  
M<sub>B</sub>/M<sub>N</sub> = break down torque / nominal torque

3) Value is valid only for DOL operation with motor design IC411  
2) at rated power / at full load

responsible dep. DI MC LVM	technical reference	created by DT Configurator	approved by	<i>Technical data are subject to change! There may be discrepancies between software and hardware versions</i>			
	document type datasheet	document status released		customer			
	title 1LE2421-4DA11-3AA3	document number					
© Siemens AG 2022	rev. 01	creation date 2022-04-09 00:19	language en	Page 1/1			

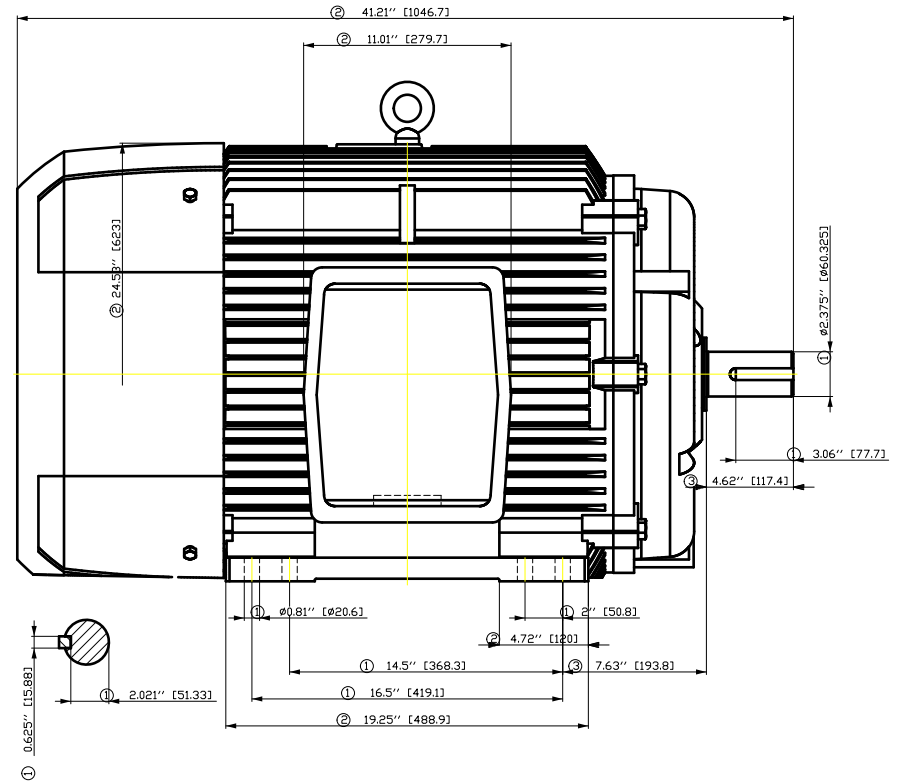
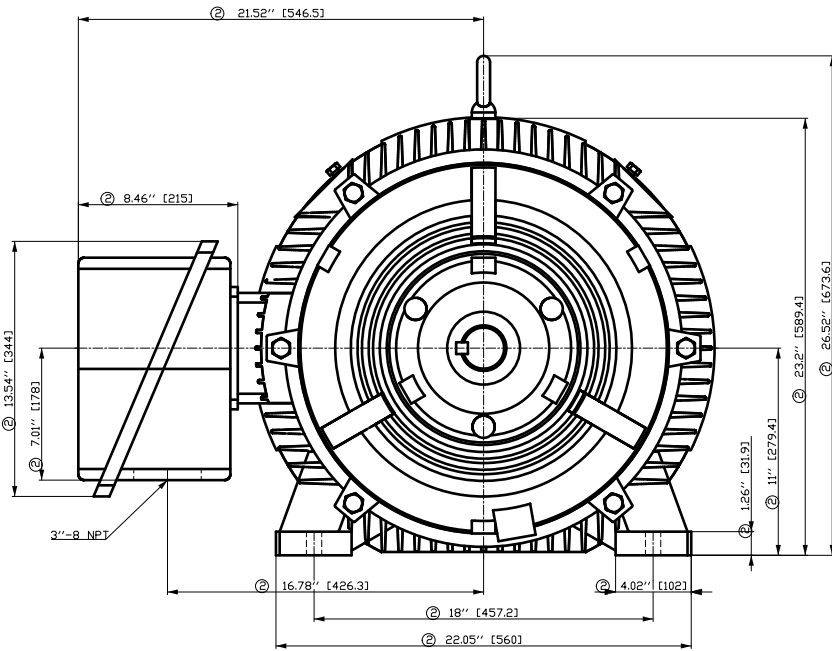

- ① Tolerances according to NEMA std.
- ② All these dimensions corresponding to assemblies and castings shall have a tolerance as per DIN standard 1686-GTB 19.
- ③ Not according to NEMA std.

Tolerance	Surface	Material	Weight	Scale
F50G GF8 ÖCFFH00H E	Author Creator Approval Department Change Order	ÖS Tæ: ^æ@` }*	E	{ {
SIEMENS	Doc. State	Item No	Doc Type	
	Revision	Index	Doc No	Paper Size
© Siemens AG 2018	Project No	Ref No	1st Language	2nd Language
	E	E	^	â^
			Sheet	F of F

# SIEMENS INDUSTRY, INC.

HP 125 VOLTS < 600V RPM 3600 TYPE SD100 IEEE841  
HZ 60 PHASE 3 FRAME 444TS NEMA B

## TORQUE & CURRENT VS. SPEED

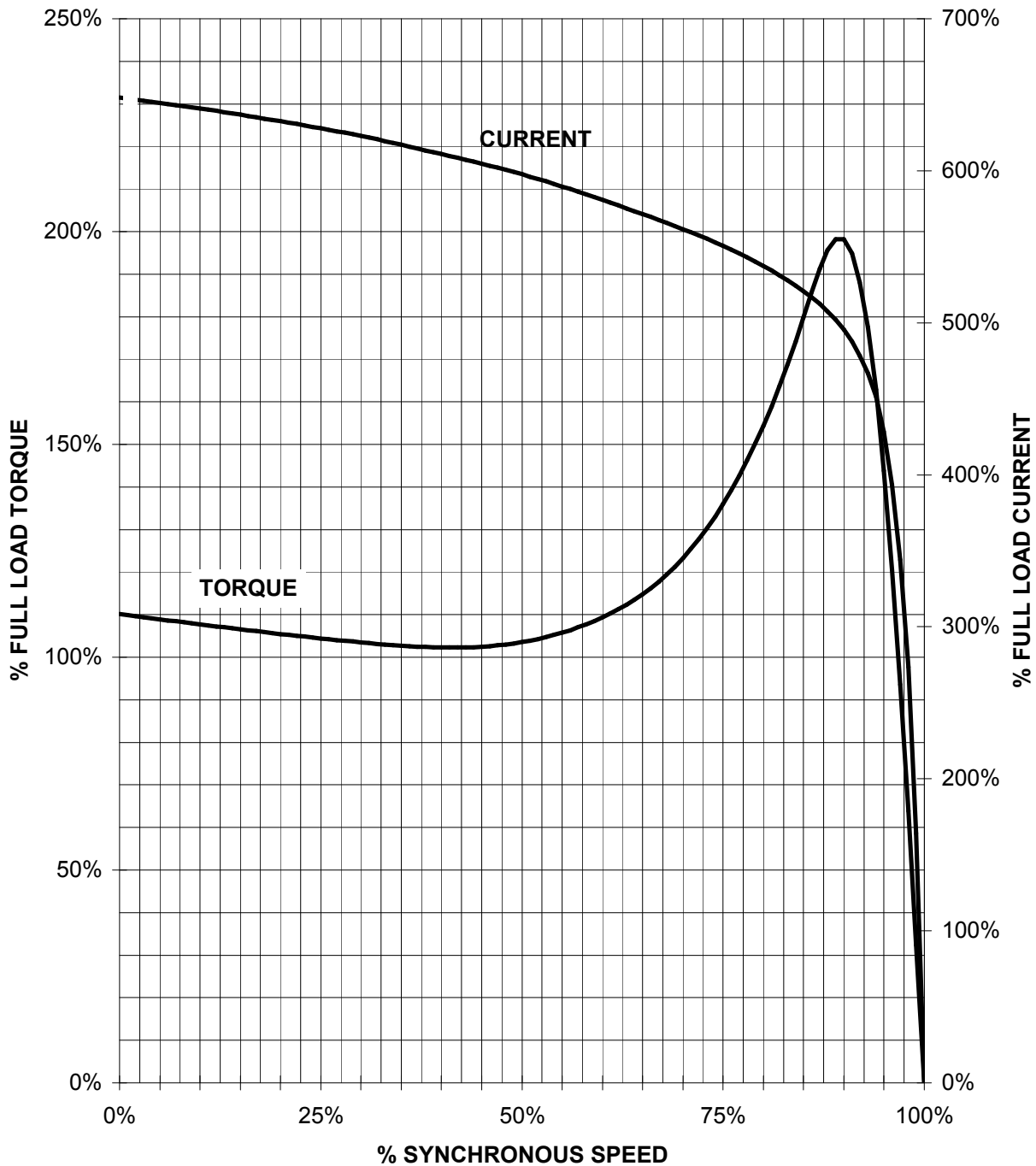

CUSTOMER: \_\_\_\_\_ ORDER#: \_\_\_\_\_

125 HP 3600 RPM 444TS FRAME 575 VOLTS 3 PHASE NEMA DESIGN B

**SIEMENS INDUSTRY, INC.**  
**PERFORMANCE CURVE**  
**SD100 IEEE841**

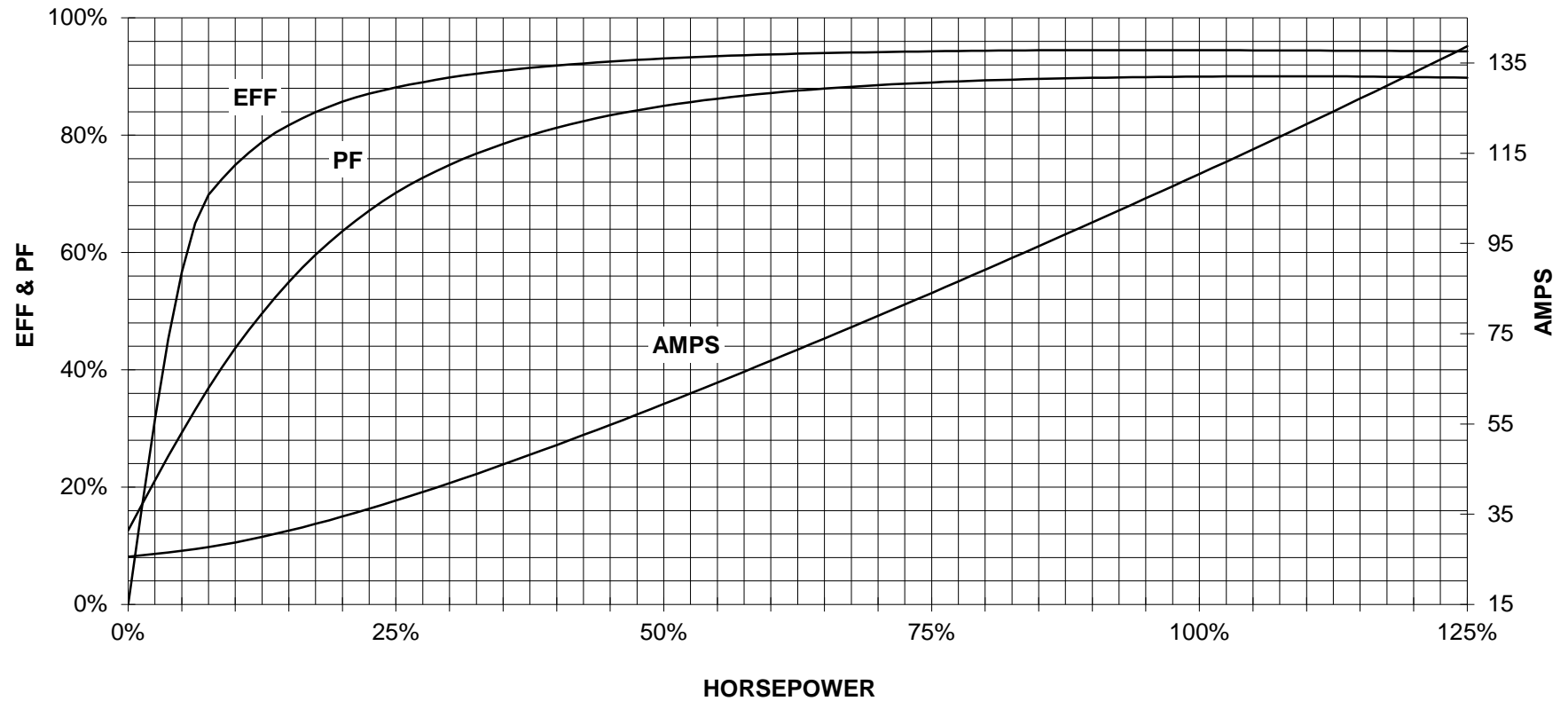

CUSTOMER \_\_\_\_\_ ORDER # \_\_\_\_\_ PO # \_\_\_\_\_

PERFORMANCE BASED ON DESIGN CALCULATIONS. SUBJECT TO CHANGE WITHOUT NOTICE.

REV. 1

Main terminal diagram

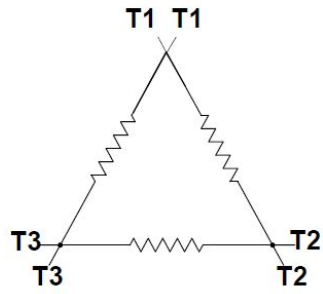

6 LEAD DELTA			
LINES			CONN.
L1	L2	L3	
T1	T2	T3	Δ

responsible dep. DI MC LVM	technical reference	created by	approved by	Project	
	document type Wiring Diagram		document status free		customer
	title 1LE2421-4DA11-3AA3		document number		
© Siemens AG 2019		rev. 01	creation date 12/03/2019	language en	Page 1/1