

Data sheet for three-phase Squirrel-Cage-Motors SIMOTICS

Motor type: **SD661** FS: **364T - 6p - 40 hp -**

Client order no.	Item-No.	Offer no.
Order no.	Consignment no.	Project

Remarks

Electrical data

Class I Division 2 Gr. A, B, C or D, T3

U [V]	Δ / Y	f [Hz]	P [HP]	P [kW]	n [rpm]	I Load [Amps]					LRC	Nom. Eff Load [%]			Pwr. Factor Load [%]			Torque [lb-ft]	T _A /T _N LRT [%]	T _k /T _N BDT [%]
						4/4	3/4	1/2	0	4/4		3/4	2/4	4/4	3/4	2/4				
460	Δ	60	40.00	30.00	1,200	49.00	37.80	28.30	18.00	290.0	94.1	94.1	94.4	81.0	79.0	70.0	177.0	190	220	

Frame Type: 364T	Type of constr.: (A) Foot mounted - End shield	Ins. Cl.: Standard Class F Insulation	Motor Prot.: (A) Without Protection	NEMA Des.: B	S.F.: 1.15
Mtr. WT: 1,000		Temp. Rise Cl.: B	Amb. Temp.: + 40 to -20 °C @1000 m	kVA: G	IP 56

Mechanical data

Sound level (SPL / SWL) at 60 Hz	60.0 dB(A) / 71.0 dB(A)	Thickener	Polyurea
Octave Band Center Frequencies Hertz	250 500 1000 2000 4000 8000 Hz	Safe Stall Time Hot	29 s
SPL@3	48.0 53.0 54.0 53.0 52.0 50.0 dB(A)	Safe Stall Time Cold	55 s
Moment of inertia	14.8 Lb-ft ²	Frame material	cast iron
Ext Load Inertia Capability:	503.0 Lb ft ²	Color, paint shade	Standard Paint - RAL7030
Bearings		Coating (paint finish)	Standard Alkyed + Epoxy (C2)
Bearing DE NDE	NU 314 6314 Z C3 S0	Ventilation Type	
Bearing_Type	Roller Bearing Ball Bearing	Method of cooling	TEFC
AFBMA:	70RU03M0 70BC03JP30	Direction of rotation	Bidirectional
Grease		Fan Material	Polypropylen ESD
Capacity	7.5 oz 7.5 oz	VFD	CT: 4:1 VT: 20:1
Grease Type:	Exxon Mobile EM	Space heaters	without
		Brake:	without

Terminal box

Lead Wire Connection	3 LEAD - DELTA	Terminal box position	(3) F-1, Standard Floor Mount, T. Box LHS
Voltage	L1 L1 L1 Connected together	Material of terminal box	Cast Iron
---	---	Cable entry	3" NPT
---	T1 T2 T3 ---		

Notes:

I_L/I_N = locked rotor current / current nominal
M_L/M_N = locked rotor torque / torque nominal
M_B/M_N = break down torque / nominal torque

3) Value is valid only for DOL operation with motor design IC411
2) at rated power / at full load

responsible dep. DI MC LVM	technical reference	created by DT Configurator	approved by	<i>Technical data are subject to change! There may be discrepancies between software and hardware versions</i>	
	document type datasheet	document status released	customer		
	title 1LE2422-3CC11-2AA3	document number			
© Siemens AG 2022		rev. 01	creation date 2022-04-08 22:16	language en	Page 1/1

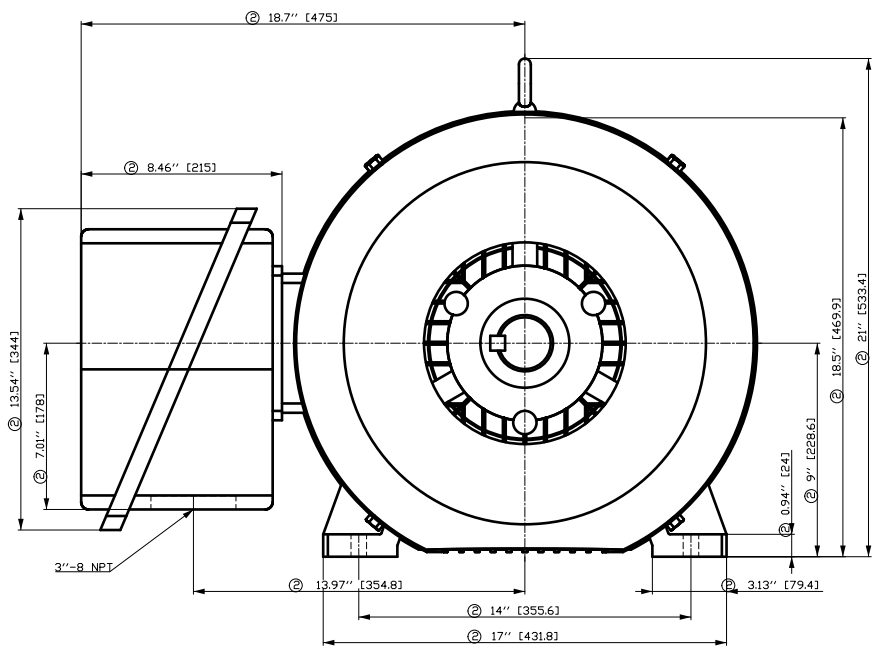

- ① Tolerances according to NEMA std.
- ② All these dimensions corresponding to assemblies and castings shall have a tolerance as per DIN standard 1686-GTB 19.
- ③ Not according to NEMA std.

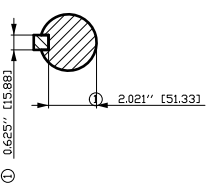
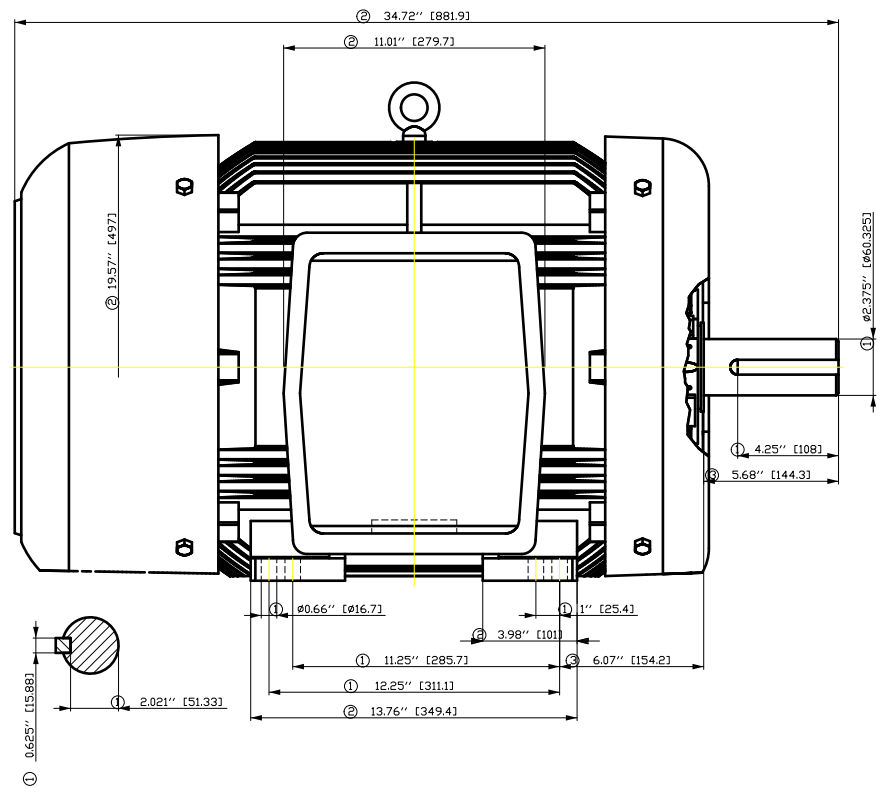

Tolerance	Surface	Material	Weight E	Scale 1:1
F50G G3H0OFFE00H E	Author Creator Approval Department Change Order	ÖVS T æ : ^æ@ } *		
SIEMENS	Doc. State Revision	I 00G Index RS	MFB Item No Doc No	Doc Type Paper Size 1st Language 2nd Language
	© Siemens AG 2018 Project No	E	E	F of F

SIEMENS INDUSTRY, INC.

HP 40 VOLTS <600 RPM 1200 TYPE SD661 IEEE841
HZ 60 PHASE 3 FRAME 364T NEMA B

TORQUE & CURRENT VS. SPEED

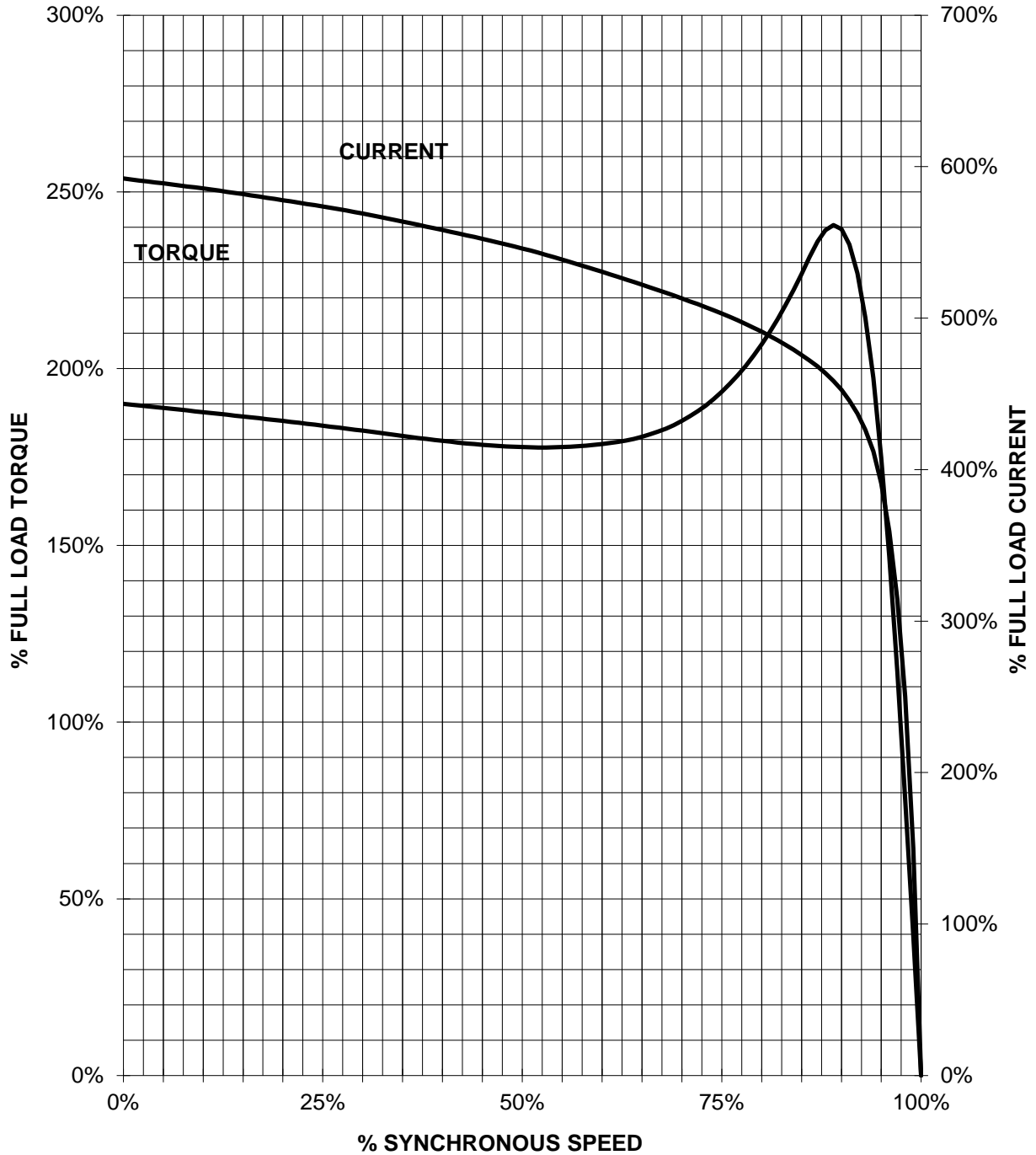

CUSTOMER: _____ ORDER#: _____

40 HP 1200 RPM 365T FRAME 460 VOLTS 3 PHASE NEMA DESIGN B

SIEMENS INDUSTRY, INC.
PERFORMANCE CURVE
SD661 IEEE841

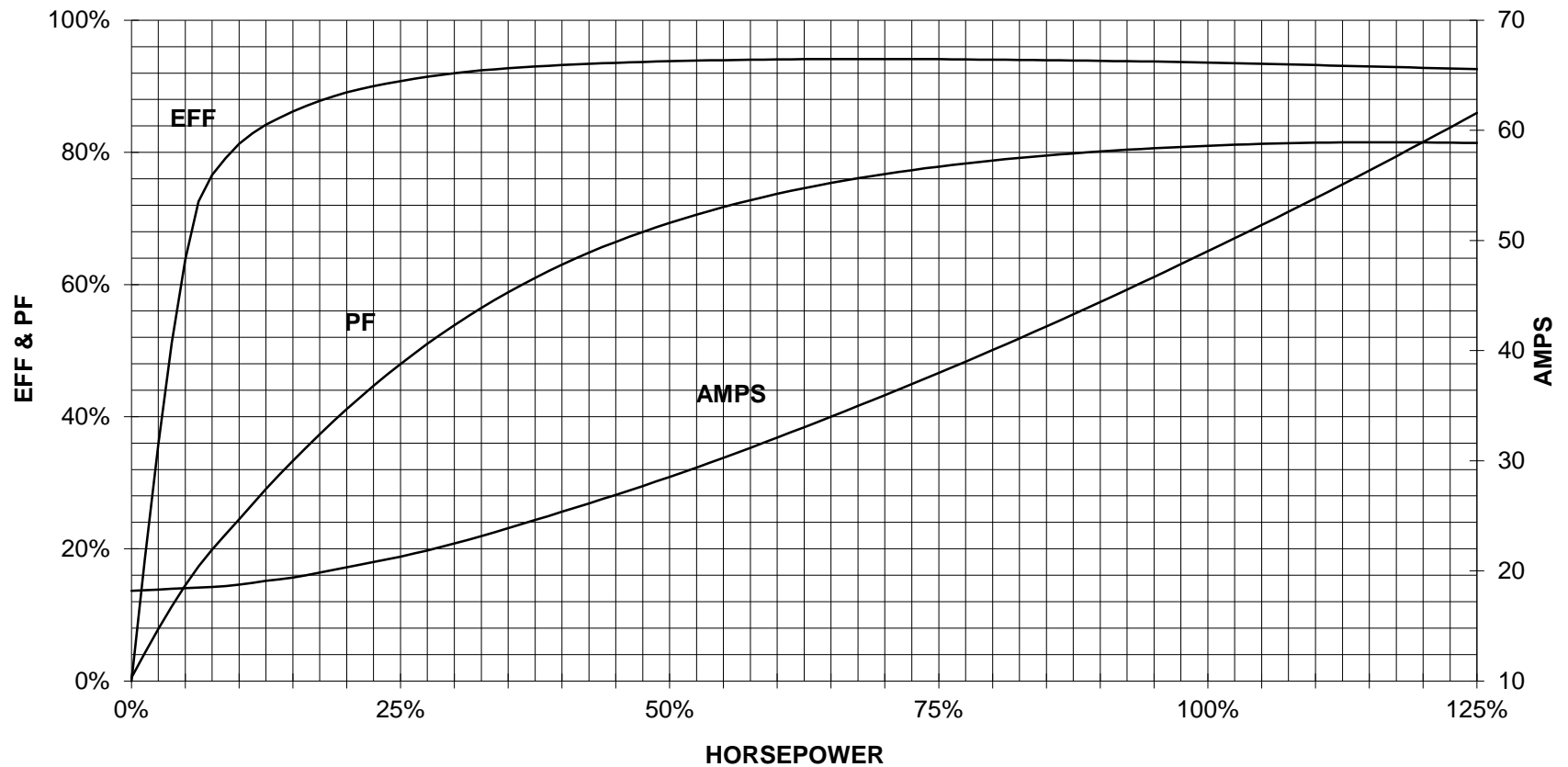

CUSTOMER _____ ORDER # _____ PO # _____

PERFORMANCE BASED ON DESIGN CALCULATIONS. SUBJECT TO CHANGE WITHOUT NOTICE.

REV. 1

Main terminal diagram



3 LEAD DELTA			
LINES			CONN.
L1	L2	L3	
T1	T2	T3	Δ

responsible dep. DI MC LVM	technical reference	created by	approved by	Project
SIEMENS	document type Wiring Diagram	document status free		customer
	title 1LE2422-3CC11-2AA3	document number		
© Siemens AG 2019		rev. 01	creation date 12/03/2019	language en Page 1/1