

Data sheet for three-phase Squirrel-Cage-Motors SIMOTICS

Motor type: SD200 NEMA Premium Next Generation **FS: 5,010 - 6p - 350 hp -**

Client order no.	Item-No.	Offer no.
Order no.	Consignment no.	Project

Remarks

Electrical data **Class I Division 2 Gr. A, B, C or D T3**

U [V]	Δ/Y	f [Hz]	P [HP]	P [kW]	n [rpm]	I Load [Amps]					Nom. Eff Load [%]			Pwr. Factor Load [%]			Torque [lb-ft]	T _A /T _N LRT [%]	T _k /T _N BDT [%]
						4/4	3/4	1/2	0	LRC	4/4	3/4	2/4	4/4	3/4	2/4			
460	$\Delta \Delta$	60	350.00	261.10	1,190	410	312.20	228.30	140.00	2550.0	96.2	96.6	96.6	84.1	81.5	74.3	1543.0	270	250

Frame Type: 5,010	Type of constr.: (A) Foot Mounted Horizontal (IMB3)	Ins. Cl.: Standard Class H Insulation	Motor Prot.: A: No Winding Protection	NEMA Des.: B	S.F.: 1.15
Mtr. WT: 4,387		Temp. Rise Cl.: B	Amb. Temp.: + 40 to °C @1000 m	kVA: G	IP 55

Mechanical data

Sound level (SPL / SWL) at 60 Hz	77.0 dB(A) / 90.0 dB(A)		Thickener	Polyurea					
Octave Band Center Frequencies Hertz			Safe Stall Time Hot	30 s					
	250	500	1000	2000	4000	8000	Hz	Safe Stall Time Cold	35 s
SPL@3	72.0	72.0	66.0	60.0	54.0	50.0	dB(A)	Frame material	Cast iron
Moment of inertia	229.0 Lb-ft ²		Color, paint shade	RAL 7030					
Ext Load Inertia Capability:	3720.0 Lb ft ²		Coating (paint finish)	Standard Alkyed + Epoxy (C2)					
Bearings			Ventilation Type						
Bearing DE NDE	6322 Z C3 S0		6322 Z C3 S0	Method of cooling	TEFC				
Bearing_Type	Ball Bearing		Ball Bearing	Direction of rotation	Bi-Directional				
AFBMA:	110BC03JP3		110BC03JP3	Fan Material	Polypropylene ESD				
Grease			VFD	CT: 4:1 VT: 20:1					
Capacity	17 oz		17 oz	Space heaters	without				
Grease Type:	Exxon Mobil EM		Brake:	-/-					

Terminal box

Lead Wire Connection	12 TERMINAL - Connection DELTA					Terminal box position	(1) LHS Mount - View From DE (F-1) - DE or Center of Motor
Voltage	L1	L1	L1	Connected together		Material of terminal box	Cast Iron
---	---	---	---	---	-	Cable entry	(1) 5" NPT
RUN	T12-T7-T6-T1	T10-T8-T4-T2	T11-T9-T5-T13	---	$\Delta \Delta$		

Notes:
 I_L/I_N = locked rotor current / current nominal
 M_L/M_N = locked rotor torque / torque nominal
 M_d/M_N = break down torque / nominal torque
 3) Value is valid only for DOL operation with motor design IC411
 2) at rated power / at full load

responsible dep.	technical reference	created by	approved by	<i>Technical data are subject to change! There may be discrepancies between software and customer interface</i>
DI MC LVM		DT Configurator		

	document type	document status	customer	
	datasheet	released		
	title	document number		
	1LE6321-5AC21-2AA1			
		rev.	creation date	language Page
		01	2022-04-08 01:09	en 1/1

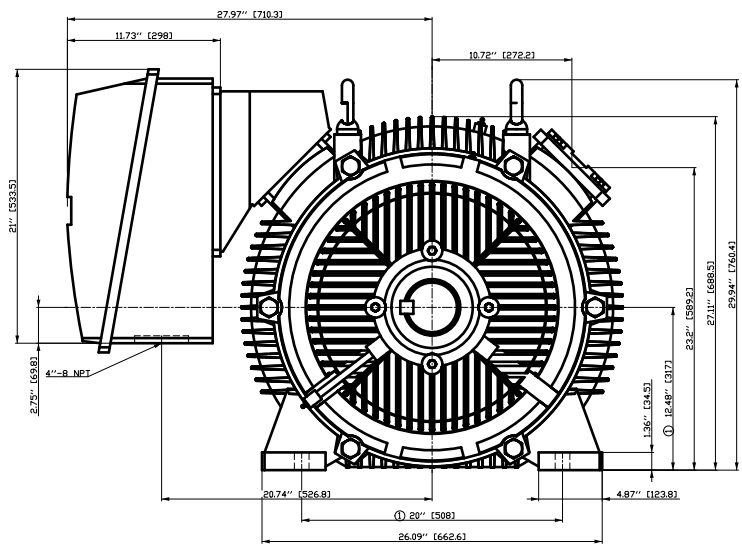

① Tolerances according to NEMA std.
 All dimensions corresponding to assemblies and castings shall have a tolerance as per ISO 8062-3 DCTG 12.

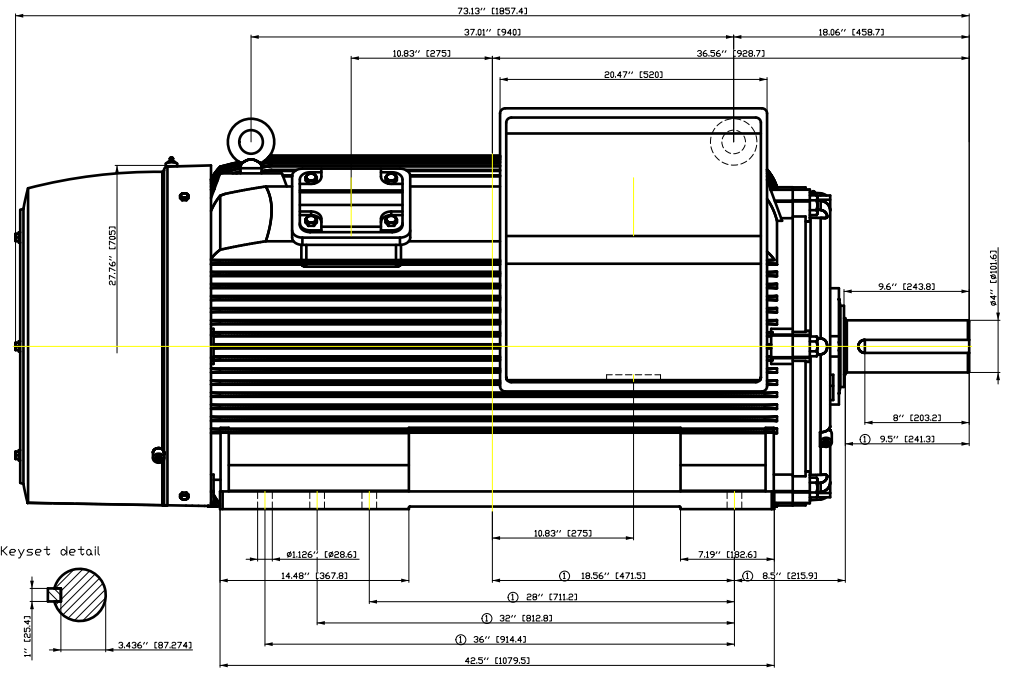

Keyset detail

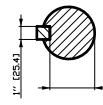

Tolerance	Surface	Material	Weight	Scale
F501 HGF E			E	{ { }
Author	Creator	ÖVS	Ö a ^) • 4) 2 4 / 2 3 3 *	
Approval	Department		T a e : ^ 2 0 ~ } *	
Change Order	Doc State	MLFB	Doc Type	/
Doc State	Revision	Index	Item No	Paper Size
SIEMENS	RS		Doc No	1st Language ^)
© Siemens AG 2018	Project No	E	Ref No	2nd Language a ^
				Sheet F of F

SIEMENS INDUSTRY, INC.

HP 350 VOLTS 460 RPM 1190 TYPE SD200
HZ 60 PHASE 3 FRAME 5010 NEMA B

TORQUE & CURRENT VS. SPEED

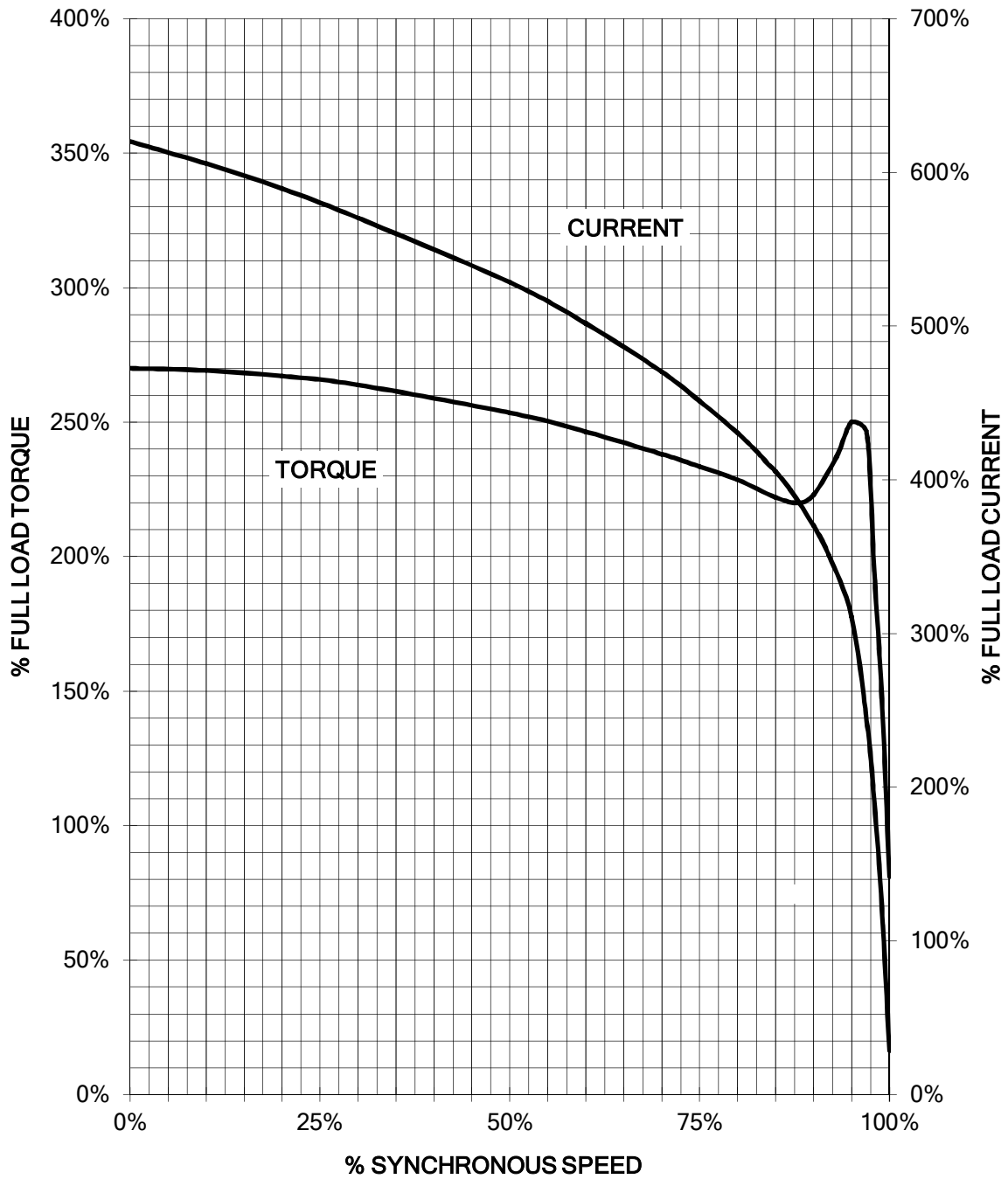

Unrestricted CUSTOMER: _____ ORDER#: _____

Main terminal diagram

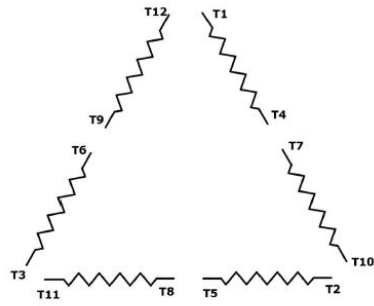

12 LEAD DELTA		
LINES	CONNECT TOGETHER	CONN.
L1	T12 - T7 - T6 - T1	ΔΔ
L2	T10 - T8 - T4 - T2	
L2	T11 - T9 - T5 - T3	

responsible dep. DI MC LVM	technical reference	created by	approved by	Project
SIEMENS	document type Wiring Diagram	document status free		customer
	title 1LE6321-5AC21-2AA1	document number		
© Siemens AG 2019	rev. 01	creation date 12/03/2019	language en	Page 1/1