

Data sheet for three-phase Squirrel-Cage-Motors SIMOTICS

Motor type: SD200 NEMA Premium Next Generation **FS: 5011S - 2p - 600 hp -**

Client order no.	Item-No.	Offer no.
Order no.	Consignment no.	Project
Remarks		

Electrical data **Class I Division 2 Gr. A, B, C or D T3**

U [V]	Δ/Y	f [Hz]	P [HP]	P [kW]	n [rpm]	I Load [Amps]					Nom. Eff Load [%]			Pwr. Factor Load [%]			Torque [lb-ft]	T _A /T _N LRT [%]	T _k /T _N BDT [%]
						4/4	3/4	1/2	0	LRC	4/4	3/4	2/4	4/4	3/4	2/4			
460	$\Delta \Delta$	60	600.00	447.60	3,585	650	500.30	361.90	145.00	4250.0	96.7	96.8	96.3	89.1	87.0	80.6	877.7	190	230

Frame Type: 5011S	Type of constr.: (A) Foot Mounted Horizontal (IMB3)	Ins. Cl.: Standard Class H Insulation	Motor Prot.: K: Stator RTD's, 2 Per Phase	NEMA Des.: -/-	S.F.: 1.15
Mtr. WT: 4,631		Temp. Rise Cl.: B	Amb. Temp.: + 40 to °C @1000 m	kVA: G	IP 55

Mechanical data

Sound level (SPL / SWL) at 60 Hz	82.0 dB(A) / 95.0 dB(A)		Thickener	Polyurea					
Octave Band Center Frequencies Hertz			Safe Stall Time Hot	17 s					
	250	500	1000	2000	4000	8000	Hz	Safe Stall Time Cold	22 s
SPL@3	79.0	74.0	73.0	72.0	72.0	67.0	dB(A)	Frame material	Cast iron
Moment of inertia	121.0 Lb-ft ²		Color, paint shade	RAL 7030					
Ext Load Inertia Capability:	443.0 Lb ft ²		Coating (paint finish)	Standard Alkyed + Epoxy (C2)					
Bearings			Ventilation Type						
Bearing DE NDE	6316 Z C3 S0		6316 Z C3 S0	Method of cooling	TEFC				
Bearing_Type	Ball Bearing		Ball Bearing	Direction of rotation	Bi-Directional				
AFBMA:	80BC03JP3		80BC03JP3	Fan Material	Polypropylene ESD				
Grease			VFD	CT: 4:1 VT: 20:1					
Capacity	9 oz		9 oz	Space heaters	without				
Grease Type:	Exxon Mobil EM		Brake:	-/-					

Terminal box

Lead Wire Connection	12 TERMINAL - Connection DELTA				Terminal box position	(1) LHS Mount - View From DE (F-1) - DE or Center of Motor
Voltage	L1	L1	L1	Connected together	Material of terminal box	Cast Iron
---	---	---	---	---	Cable entry	(1) 5" NPT
RUN	T12-T7-T6-T1	T10-T8-T4-T2	T11-T9-T5-T13	---		



Notes:
 I_r/I_N = locked rotor current / current nominal
 M_r/M_N = locked rotor torque / torque nominal
 M_d/M_N = break down torque / nominal torque
 3) Value is valid only for DOL operation with motor design IC411
 2) at rated power / at full load

responsible dep. DI MC LVM	technical reference	created by DT Configurator	approved by	<i>Technical data are subject to change! There may be discrepancies between software and hardware versions.</i>
-------------------------------	---------------------	-------------------------------	-------------	-----------------------------------------------------------------------------------------------------------------

	document type datasheet	document status released	customer	
	title 1LE6321-5EA01-2AK1	document number		
© Siemens AG 2022	rev. 01	creation date 2022-04-08 01:15	language en	Page 1/1

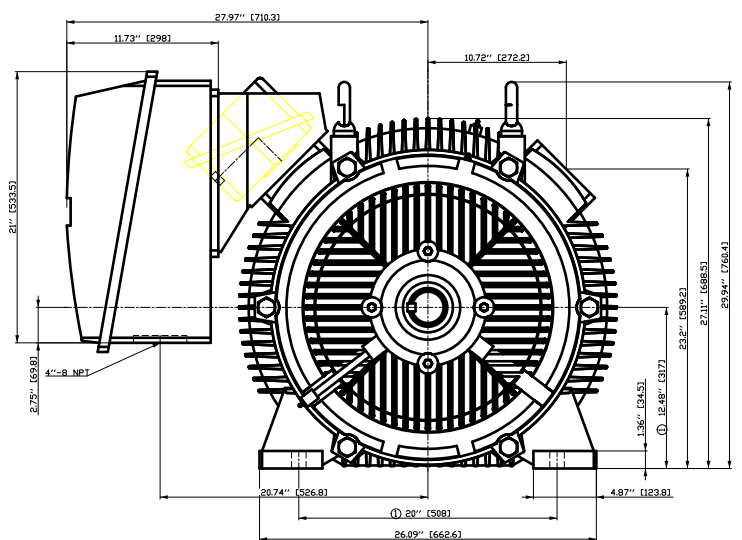

① Tolerances according to NEMA std.
 All dimensions corresponding to assemblies and castings shall have a tolerance as per ISO 8062-3 DCTG 12.

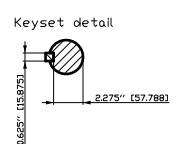
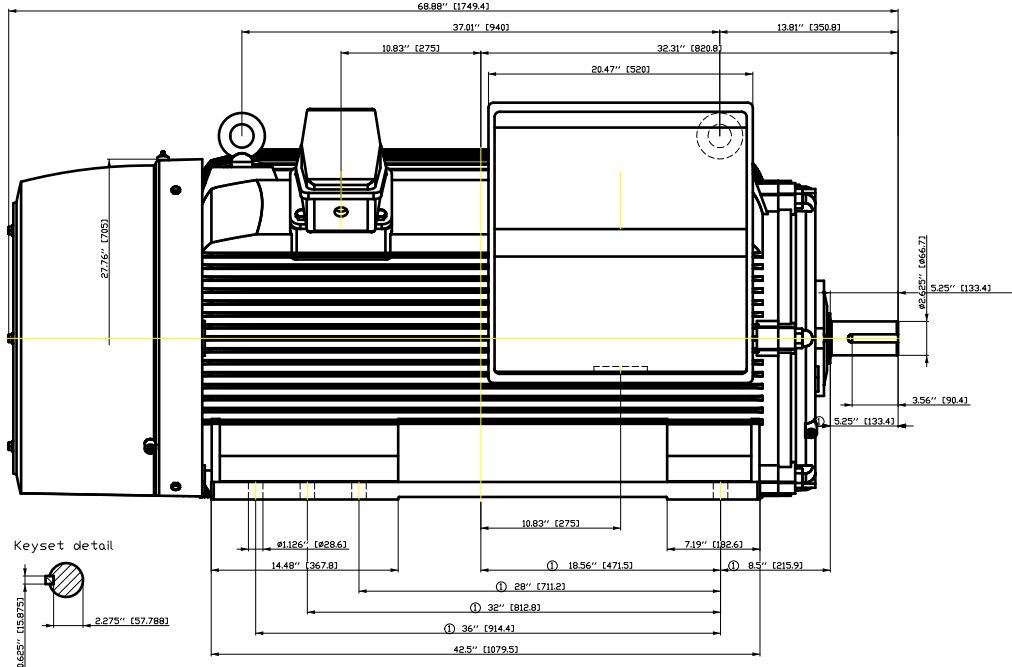

Tolerance	Surface	Material	Weight E	Scale 1:1
F501 HGF E ÖVS F505 F	Author Creator Approval Department Change Order	ÖS T a : ^ @ ~ } *		
SIEMENS © Siemens AG 2018	Doc State Revision	I B B G Index RS	MLFB Item No Doc No	Doc Type Paper Size 1st Language 2nd Language
	Project No	E	Ref No	E

刀线... 用... 为... 于... 口... 皮... 积...
 刀线... 用... 为... 于... 口... 皮... 积...
 刀线... 用... 为... 于... 口... 皮... 积...
 刀线... 用... 为... 于... 口... 皮... 积...

Main terminal diagram

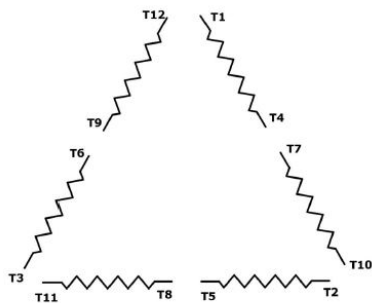

12 LEAD DELTA		
LINES	CONNECT TOGETHER	CONN.
L1	T12 - T7 - T6 - T1	ΔΔ
L2	T10 - T8 - T4 - T2	
L2	T11 - T9 - T5 - T3	

Motor protection

3 WIRE STATOR RTDs

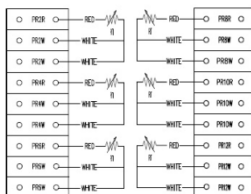

responsible dep.
DI MC LVM

technical reference

created by

approved by

Project

SIEMENS

document type
Wiring Diagram

title
1LE6321-5EA01-2AK1

document status
free

document number

customer