

Data sheet for three-phase Squirrel-Cage-Motors SIMOTICS

Motor type: FS: 184T - 2p - 5 hp -

Client order no.	Item-No.	Offer no.
Order no.	Consignment no.	Project
Remarks		

Electrical data Class I, Div 1 Gr. C&D; Class II, Div1, Gr. F&G

U [V]	Δ/Y	f [Hz]	P [HP]	P [kW]	n [rpm]	I Load [Amps]					LRC	Nom. Eff Load [%]			Pwr. Factor Load [%]			Torque [lb-ft]	T _A /T _N LRT [%]	T _k /T _N BDT [%]
						4/4	3/4	1/2	0	4/4		3/4	2/4	4/4	3/4	2/4				
460		60	5.00	-/-	3,505	6.00	4.60	3.40	2.00	46.0	88.5	89.1	88.2	88.2	85.9	78.1	7.5	173	427	
230		60	5.00	-/-	3,505	12.00					88.5	89.1	88.2	88.2	85.9	78.1	7.5	173	427	

Frame Type: 184T	Type of constr.: (A) Foot mounted - End shield	Ins. Cl.:Insulation class F	Motor Prot.:(G) Thermostats, Klixon type, normally closed	NEMA Des.: B	S.F.: 1.15
Mtr. WT:105		Temp. Rise Cl.: B	Amb. Temp.: + to -20 °C @1000 m	kVA: J	IP IP65

Mechanical data

Sound level (SPL / SWL) at 60 Hz	69.0 dB(A) / 81.0 dB(A)	Thickener	Polyurea
Octave Band Center Frequencies Hertz	250 500 1000 2000 4000 8000 Hz	Safe Stall Time Hot	15 s
SPL@3	dB(A)	Safe Stall Time Cold	29 s
Moment of inertia	0.2 Lb-ft ²	Frame material	cast iron
Ext Load Inertia Capability:	6.0 Lb ft ²	Color, paint shade	
Bearings		Coating (paint finish)	
Bearing DE NDE	6206 Z C3 S0 6206 Z C3 S0	Ventilation Type	
Bearing_Type	Ball Bearing Ball Bearing	Method of cooling	TEFC
AFBMA:	30BC02JP30 30BC02JP30	Direction of rotation	Bidirectional
Grease		Fan Material	Polypropylen ESD
Capacity	0.2 oz 0.2 oz	VFD	CT: 4:1 VT: 20:1
Grease Type:	Exxon Mobile EM	Space heaters	without
		Brake:	-/-

Terminal box

Lead Wire Connection	9 LEAD - WYE	Terminal box position	(3) Mounting - F-1
Voltage	L1 L1 L1 Connected together	Material of terminal box	
LOW	T1 T7 T2 T8 T3 T9 T4 T5 T6	Cable entry	-/-
HIGH	T1 T2 T3 T4 T7-T5 T8-T6 T9		

Notes:

I_r/I_N = locked rotor current / current nominal
M_r/M_N = locked rotor torque / torque nominal
M_b/M_N = break down torque / nominal torque
3) Value is valid only for DOL operation with motor design IC411
2) at rated power / at full load

responsible dep. DI MC LVM	technical reference	created by DT Configurator	approved by	<i>Technical data are subject to change! There may be discrepancies between software and hardware versions</i>	
	document type datasheet	document status released	customer		
	title 1MB2121-1CA31-4AG3	document number			
© Siemens AG 2022	rev. 01	creation date 2022-04-08 17:43	language en	Page 1/1	

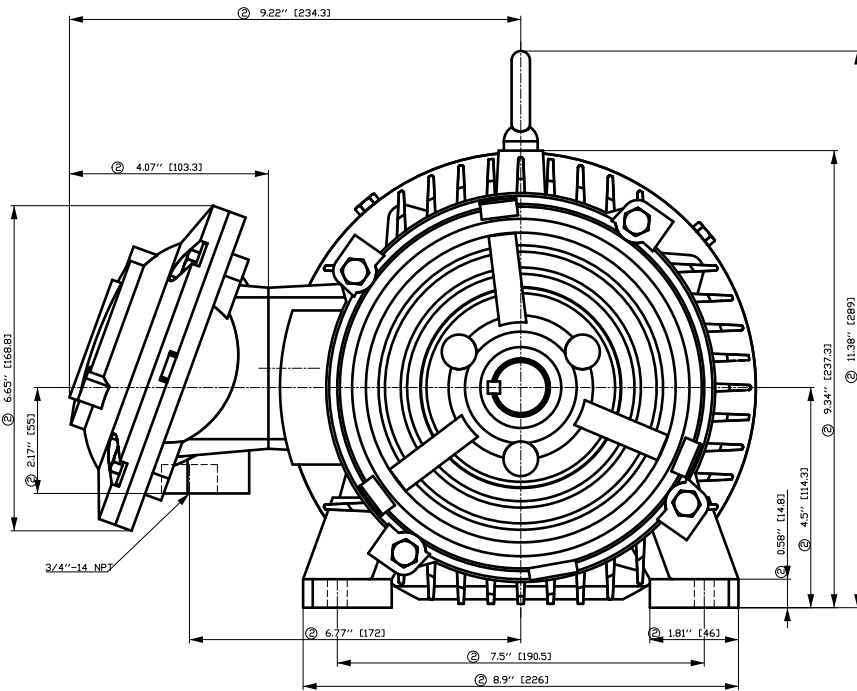

① Tolerances according to NEMA std.

② All these dimensions corresponding to assemblies and castings shall have a tolerance as per DIN standard 1686-GTB 19.

③ Not according to NEMA std.

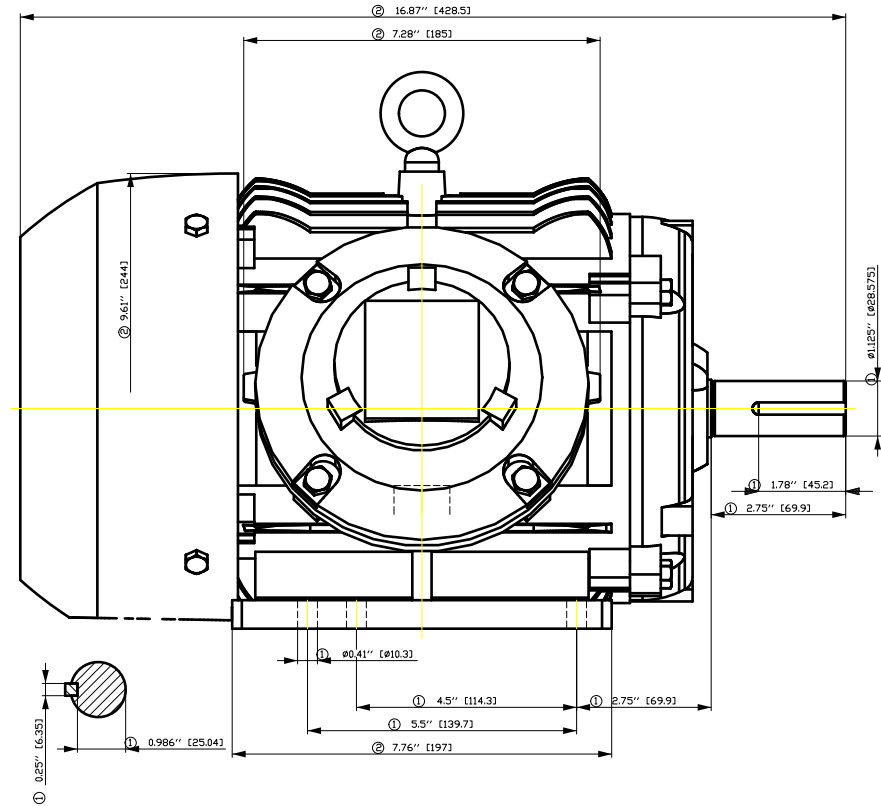

Tolerance	Surface	Material	Weight É	Scale ⌀ { }		
FT ÖGF CF Ê Ö Ö F Ê Ê Ö Ö H É	Author Creator ÖVS Approval Department Change Order	Öâ \) • ¼ } ¼ } ¼ } ¼ } * T æ : ^ ¼ @ } } * MFB				
	Doc. State I ð ÖGG				Item No	Doc Type
	Revision Index RS				Doc No	Paper Size CH
© Siemens AG 2018	Project No É				Ref No É	1st Language ^ 2nd Language â^
						Sheet F of F

Main terminal diagram



9 LEAD WYE					
Volts	LINES			CONNECTED TOGETHER	CONN.
	L1	L2	L3		
LOW	T1 T7	T2 T6	T3 T9	T4 T5 T6	YY
HIGH	T1	T2	T3	T4 T7-T5 T8-T6 T9	Y

Motor protection

THERMOSTATS



responsible dep.
DI MC LVM

technical reference

created by

approved by

Project

SIEMENS

document type
Wiring Diagram

title
1MB2121-1CA31-4AG3

document status
free

document number

customer

SIEMENS INDUSTRY, INC.

HP 5 VOLTS <600 RPM 3600 TYPE XP100
HZ 60 PHASE 3 FRAME 184T NEMA B

TORQUE & CURRENT VS. SPEED

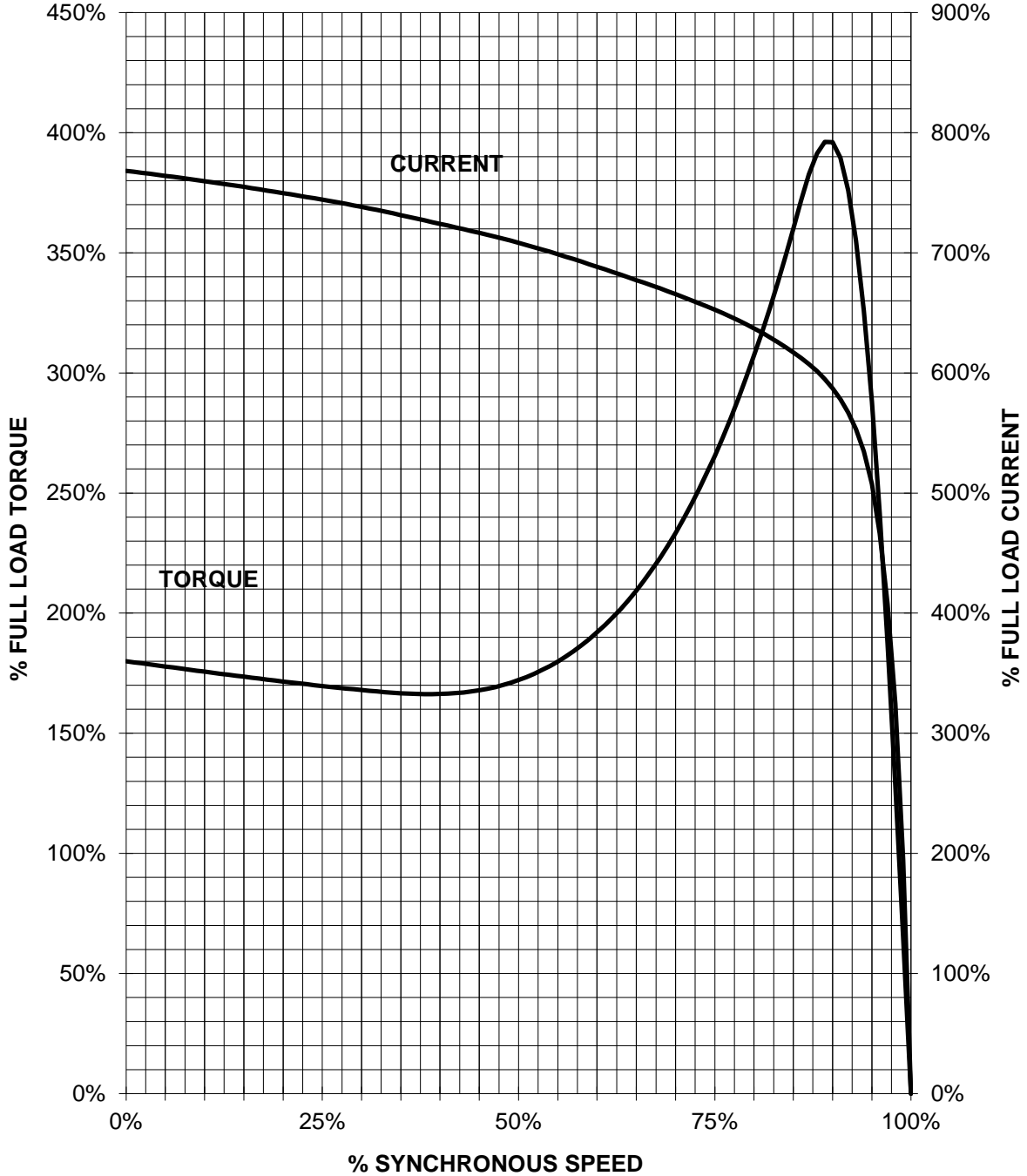

CUSTOMER: _____ ORDER#: _____

5 HP 3600 RPM 184T FRAME 460 VOLTS 3 PHASE NEMA DESIGN B

**SIEMENS INDUSTRY, INC.
PERFORMANCE CURVE
XP100**

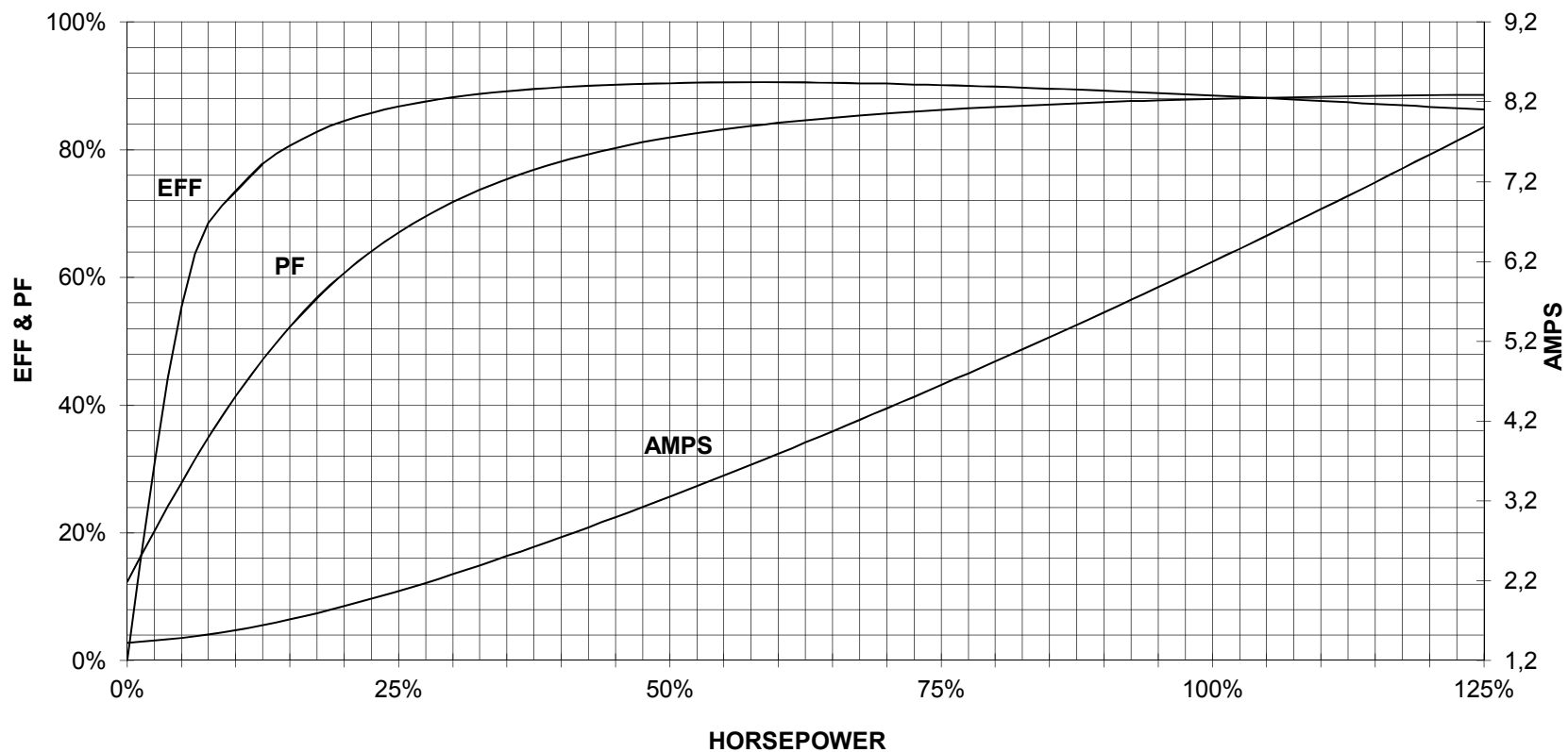

CUSTOMER _____ ORDER # _____ PO # _____

PERFORMANCE BASED ON DESIGN CALCULATIONS. SUBJECT TO CHANGE WITHOUT NOTICE.

REV. 1