

# Data sheet for three-phase Squirrel-Cage-Motors SIMOTICS

**Motor type:** FS: 184T - 6p - 2 hp -

|                  |                 |           |
|------------------|-----------------|-----------|
| Client order no. | Item-No.        | Offer no. |
| Order no.        | Consignment no. | Project   |

Remarks

**Electrical data** Class I, Div 1 Gr. C&D; Class II, Div1, Gr. F&G

| U [V] | $\Delta/Y$ | f [Hz] | P [HP] | P [kW] | n [rpm] | I Load [Amps] |      |      |      |      | LRC  | Nom. Eff Load [%] |      |      | Pwr. Factor Load [%] |      |     | Torque [lb-ft] | T <sub>A</sub> /T <sub>N</sub> LRT [%] | T <sub>k</sub> /T <sub>N</sub> BDT [%] |
|-------|------------|--------|--------|--------|---------|---------------|------|------|------|------|------|-------------------|------|------|----------------------|------|-----|----------------|--|--|
|       |            |        |        |        |         | 4/4           | 3/4  | 1/2  | 0    | 4/4  |      | 3/4               | 2/4  | 4/4  | 3/4                  | 2/4  |     |                |  |  |
| 460   |            | 60     | 2.00   | -/-    | 1,160   | 3.20          | 2.70 | 2.30 | 1.90 | 20.0 | 88.5 | 88.7              | 87.5 | 66.1 | 58.8                 | 46.5 | 9.1 | 242            | 308                                    |  |
| 230   |            | 60     | 2.00   | -/-    | 1,160   | 6.40          |      |      |      |      | 88.5 | 88.7              | 87.5 | 66.1 | 58.8                 | 46.5 | 9.1 | 242            | 308                                    |  |

|                  |  |                             |   |              |            |
|------------------|--|-----------------------------|---|--------------|------------|
| Frame Type: 184T | Type of constr.: (A) Foot mounted - End shield | Ins. Cl.:Insulation class F | Motor Prot.:(G) Thermostats, Klixon type, normally closed | NEMA Des.: B | S.F.: 1.15 |
| Mtr. WT:125      |  | Temp. Rise Cl.: B           | Amb. Temp.: + to -20 °C @1000 m                           | kVA: J       | IP IP65    |

**Mechanical data**

|                                      |                                |                         |                  |
|--------------------------------------|--------------------------------|-------------------------|------------------|
| Sound level (SPL / SWL) at 60 Hz     | 54.0 dB(A) / 63.0 dB(A)        | Thickener               | Polyurea         |
| Octave Band Center Frequencies Hertz | 250 500 1000 2000 4000 8000 Hz | Safe Stall Time Hot     | 23 s             |
| SPL@3                                |                                | Safe Stall Time Cold    | 32 s             |
| Moment of inertia                    | 0.3 Lb-ft <sup>2</sup>         | Frame material          | cast iron        |
| Ext Load Inertia Capability:         | 30.0 Lb ft <sup>2</sup>        | Color, paint shade      |                  |
| <b>Bearings</b>                      |                                | Coating (paint finish)  |                  |
| Bearing DE   NDE                     | 6206 Z C3 S0   6206 Z C3 S0    | <b>Ventilation Type</b> |                  |
| Bearing_Type                         | Ball Bearing   Ball Bearing    | Method of cooling       | TEFC             |
| AFBMA:                               | 30BC02JP30   30BC02JP30        | Direction of rotation   | Bidirectional    |
| <b>Grease</b>                        |                                | Fan Material            | Polypropylen ESD |
| Capacity                             | 0.2 oz   0.2 oz                | VFD                     | CT: 4:1 VT: 20:1 |
| Grease Type:                         | Exxon Mobile EM                | Space heaters           | without          |
|                                      |                                | Brake:                  | -/-              |

**Terminal box**

|                      |                             |                          |                    |
|----------------------|-----------------------------|--------------------------|--------------------|
| Lead Wire Connection | 9 LEAD - WYE                | Terminal box position    | (3) Mounting - F-1 |
| Voltage              | L1 L1 L1 Connected together | Material of terminal box |                    |
| LOW                  | T1 T7 T2 T8 T3 T9 T4 T5 T6  | Cable entry              | -/-                |
| HIGH                 | T1 T2 T3 T4 T7-T5 T8-T6 T9  |                          |                    |

**Notes:**  
 I<sub>r</sub>/I<sub>N</sub> = locked rotor current / current nominal  
 M<sub>r</sub>/M<sub>N</sub> = locked rotor torque / torque nominal  
 M<sub>b</sub>/M<sub>N</sub> = break down torque / nominal torque  
 3) Value is valid only for DOL operation with motor design IC411  
 2) at rated power / at full load

|                               |                     |                               |             |  |
|-------------------------------|---------------------|-------------------------------|-------------|--|
| responsible dep.<br>DI MC LVM | technical reference | created by<br>DT Configurator | approved by | <i>Technical data are subject to change! There may be discrepancies between software and hardware versions</i> |
|-------------------------------|---------------------|-------------------------------|-------------|--|

|                   |                             |                                   |                |             |
|-------------------|-----------------------------|-----------------------------------|----------------|-------------|
|                   | document type<br>datasheet  | document status<br>released       | customer       |             |
|                   | title<br>1MB2121-1CC31-4AG3 | document number                   |                |             |
| © Siemens AG 2022 | rev.<br>01                  | creation date<br>2022-04-08 17:47 | language<br>en | Page<br>1/1 |

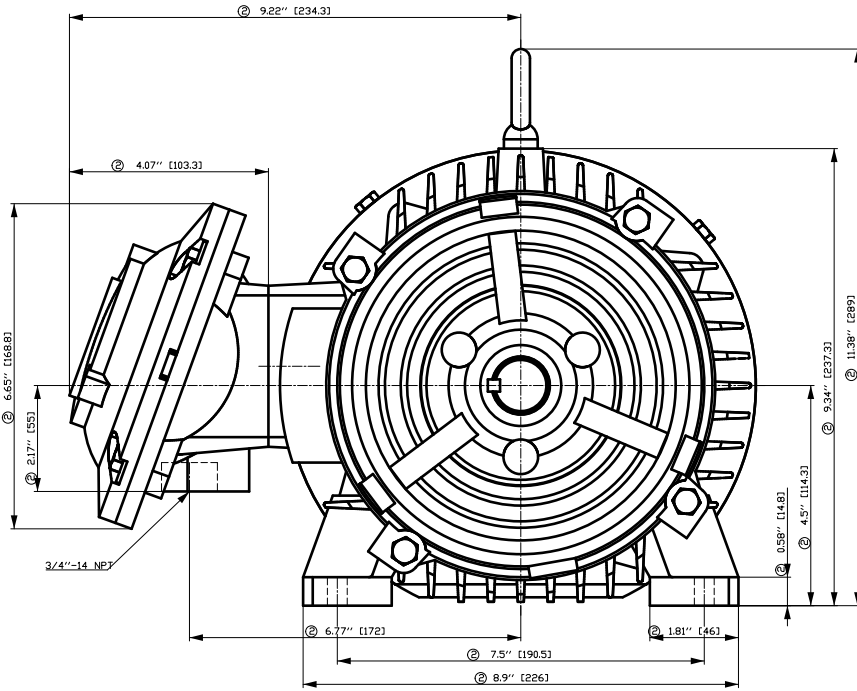

- ① Tolerances according to NEMA std.
- ② All these dimensions corresponding to assemblies and castings shall have a tolerance as per DIN standard 1686-GTB 19.
- ③ Not according to NEMA std.

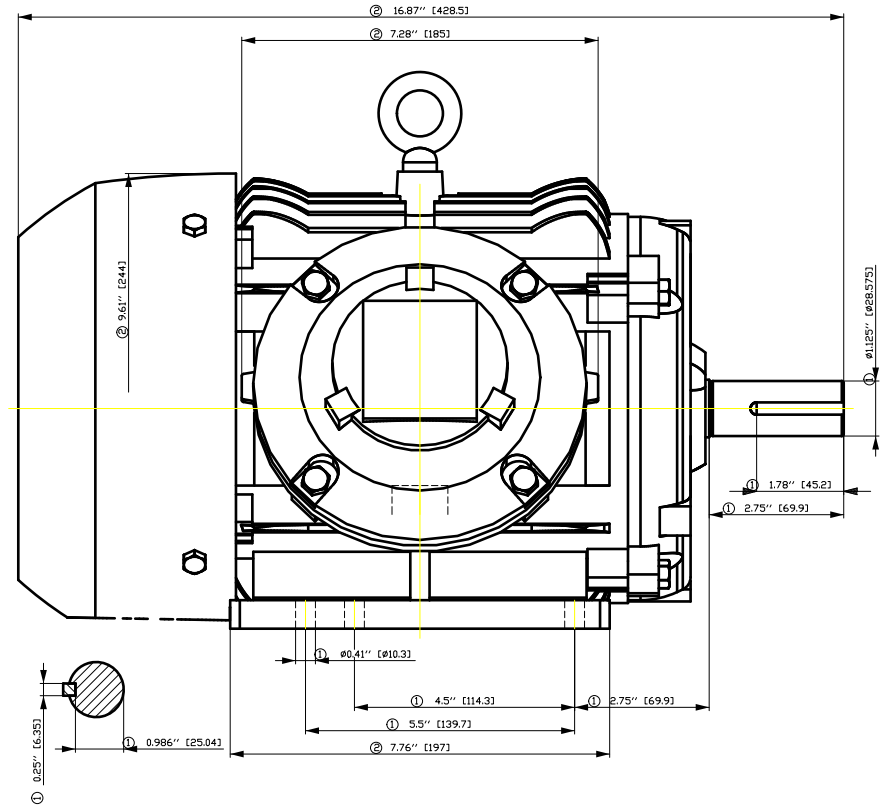

|                    |              |                  |         |                 |
|--------------------|--------------|------------------|---------|-----------------|
| Tolerance          | Surface      | Material         | Weight  | Scale           |
| FT ÖGF:FEÖÖHF# ÖÖH | Author       | Öä ^)•ä)ä/ä/ä ä* | Ë       | { {             |
| Ë                  | Creator      | ÖVS              |         |                 |
|                    | Approval     | T ä: ^ä@`)*      |         |                 |
|                    | Department   |                  |         |                 |
|                    | Change Order | MLFB             |         | Doc Type        |
| <b>SIEMENS</b>     | Doc. State   | I ð ÖÖG          | Item No | Paper Size      |
| © Siemens AG       | Revision     | Index RS         | Doc No  | 1st Language ^) |
| 2018               | Project No   | Ë                | Ref No  | 2nd Language ä^ |
|                    |              |                  |         | Sheet F of F    |

Main terminal diagram

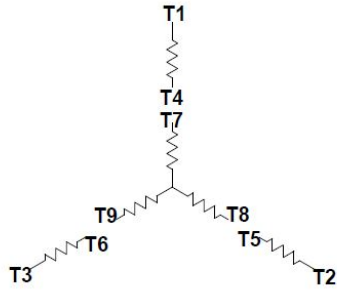

| 9 LEAD WYE |          |          |          |                    |       |  |
|------------|----------|----------|----------|--------------------|-------|--|
| Volts      | LINES    |          |          | CONNECTED TOGETHER | CONN. |  |
|            | L1       | L2       | L3       |                    |       |  |
| LOW        | T1<br>T7 | T2<br>T6 | T3<br>T9 | T4 T5 T6           | YY    |  |
| HIGH       | T1       | T2       | T3       | T4 T7-T5 T8-T6 T9  | Y     |  |

Motor protection

THERMOSTATS

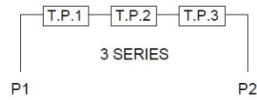

responsible dep.  
DI MC LVM

technical reference

created by

approved by

Project

**SIEMENS**

document type  
Wiring Diagram

title  
1MB2121-1CC31-4AG3

document status  
free

document number

customer

# SIEMENS INDUSTRY, INC.

HP 2 VOLTS <600 RPM 1200 TYPE XP100  
HZ 60 PHASE 3 FRAME 184T NEMA B

## TORQUE & CURRENT VS. SPEED

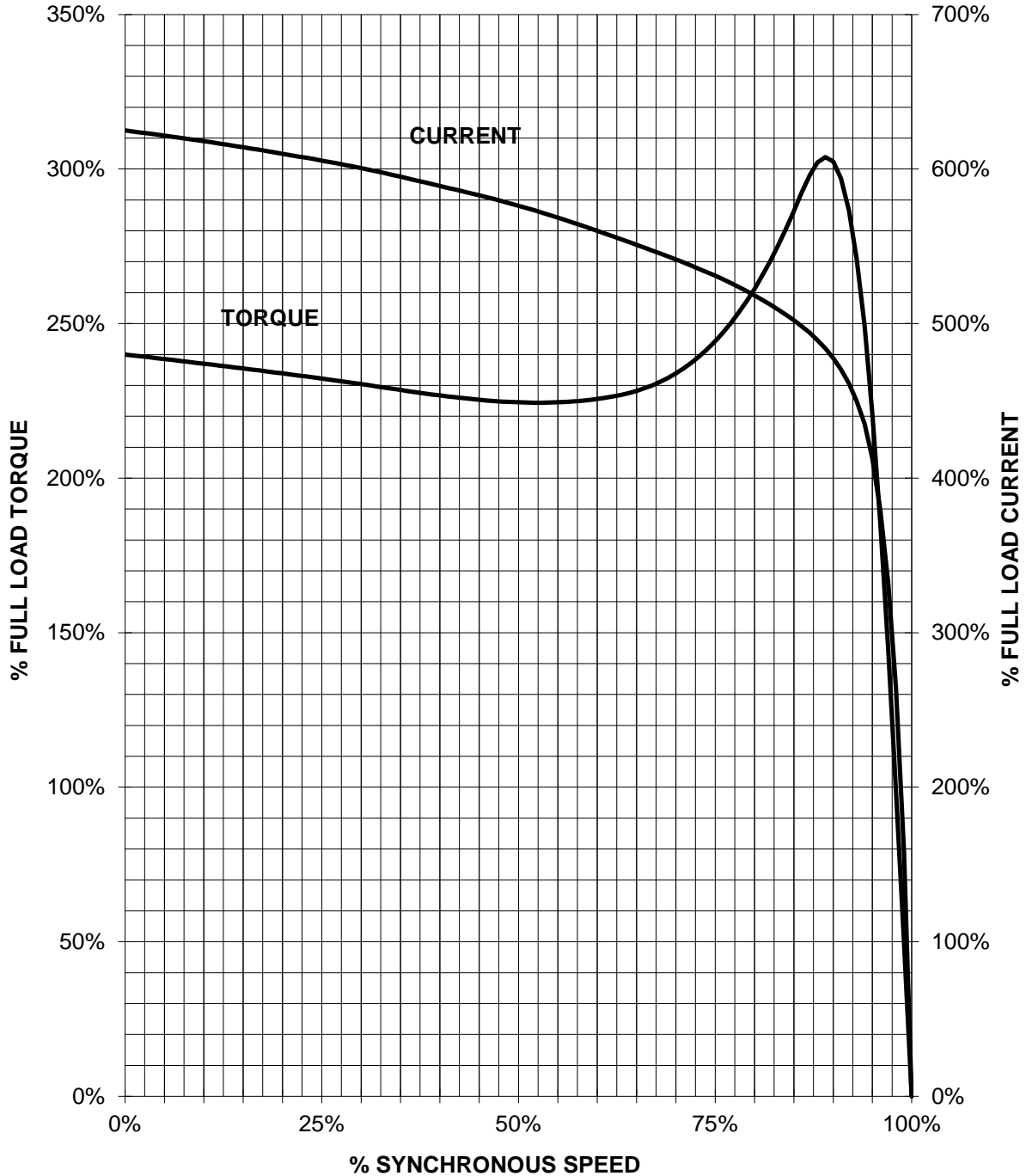

CUSTOMER: \_\_\_\_\_ ORDER#: \_\_\_\_\_

2 HP 1200 RPM 184T FRAME 460 VOLTS 3 PHASE NEMA DESIGN B

**SIEMENS INDUSTRY, INC.**  
**PERFORMANCE CURVE**  
**XP100**

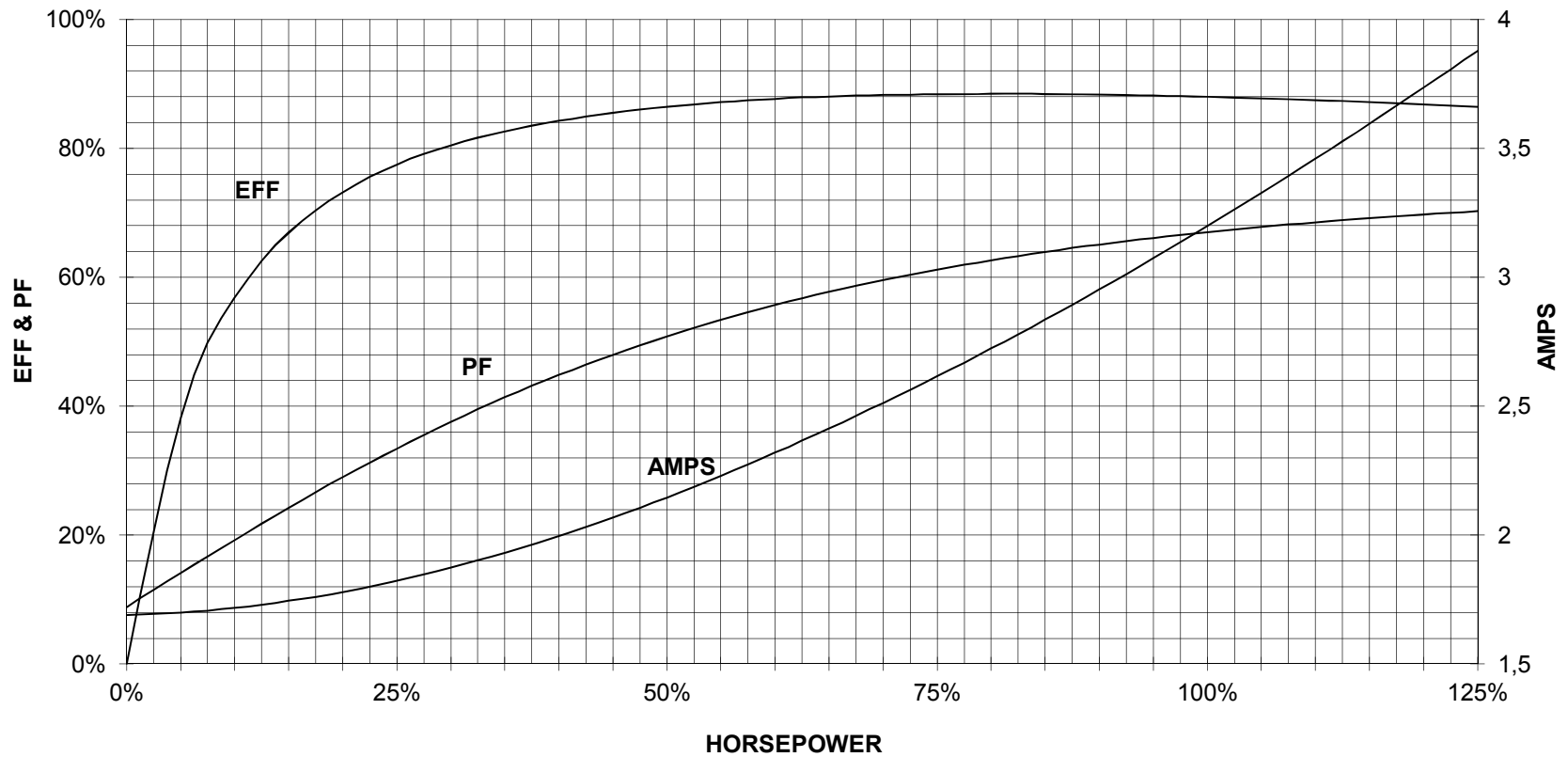

CUSTOMER \_\_\_\_\_ ORDER # \_\_\_\_\_ PO # \_\_\_\_\_

PERFORMANCE BASED ON DESIGN CALCULATIONS. SUBJECT TO CHANGE WITHOUT NOTICE.

REV. 1