

# Data sheet for three-phase Squirrel-Cage-Motors SIMOTICS

**Motor type:** FS: 182T - 8p - 1 hp -

Client order no.	Item-No.	Offer no.
Order no.	Consignment no.	Project
Remarks		

**Electrical data** Class I, Div 1 Gr. C&D; Class II, Div1, Gr. F&G

U [V]	$\Delta/Y$	f [Hz]	P [HP]	P [kW]	n [rpm]	I Load [Amps]					LRC	Nom. Eff Load [%]			Pwr. Factor Load [%]			Torque [lb-ft]	T <sub>A</sub> /T <sub>N</sub> LRT [%]	T <sub>k</sub> /T <sub>N</sub> BDT [%]
						4/4	3/4	1/2	0	4/4		3/4	2/4	4/4	3/4	2/4				
460		60	1.00	-/-	870	2.10	1.90	1.70	1.50	9.0	81.5	80.0	77.0	56.0	47.0	36.0	8.0	138	250	
230		60	1.00	-/-	870	4.20					81.5	80.0	77.0	56.0	47.0	36.0	8.0	138	250	

Frame Type: 182T	Type of constr.: (A) Foot mounted - End shield	Ins. Cl.:Insulation class F	Motor Prot.:(G) Thermostats, Klixon type, normally closed	NEMA Des.: B	S.F.: 1.15
Mtr. WT:105		Temp. Rise Cl.: B	Amb. Temp.: + to -20 °C @1000 m	kVA: J	IP IP65

**Mechanical data**

Sound level (SPL / SWL) at 60 Hz	54.0 dB(A) / 63.0 dB(A)	Thickener	Polyurea
Octave Band Center Frequencies Hertz	250 500 1000 2000 4000 8000 Hz	Safe Stall Time Hot	50 s
SPL@3		Safe Stall Time Cold	68 s
Moment of inertia	0.2 Lb-ft <sup>2</sup>	Frame material	cast iron
Ext Load Inertia Capability:	31.0 Lb ft <sup>2</sup>	Color, paint shade	
<b>Bearings</b>		Coating (paint finish)	
Bearing DE   NDE	6206 Z C3 S0   6206 Z C3 S0	<b>Ventilation Type</b>	
Bearing_Type	Ball Bearing   Ball Bearing	Method of cooling	TEFC
AFBMA:	30BC02JP30   30BC02JP30	Direction of rotation	Bidirectional
<b>Grease</b>		Fan Material	Polypropylen ESD
Capacity	0.2 oz   0.2 oz	VFD	CT: 4:1 VT: 20:1
Grease Type:	Exxon Mobile EM	Space heaters	without
		Brake:	-/-

**Terminal box**

Lead Wire Connection	9 LEAD - WYE	Terminal box position	(3) Mounting - F-1
Voltage	L1 L1 L1 Connected together	Material of terminal box	
LOW	T1 T7 T2 T8 T3 T9 T4 T5 T6	Cable entry	-/-
HIGH	T1 T2 T3 T4 T7-T5 T8-T6 T9		

**Notes:**

I<sub>r</sub>/I<sub>N</sub> = locked rotor current / current nominal  
M<sub>r</sub>/M<sub>N</sub> = locked rotor torque / torque nominal  
M<sub>b</sub>/M<sub>N</sub> = break down torque / nominal torque

3) Value is valid only for DOL operation with motor design IC411  
2) at rated power / at full load

responsible dep. DI MC LVM	technical reference	created by DT Configurator	approved by	<i>Technical data are subject to change! There may be discrepancies between software and hardware versions</i>	
	document type datasheet	document status released	customer		
	title 1MB2121-1CD11-4AG3	document number			
© Siemens AG 2022		rev. 01	creation date 2022-04-08 17:48	language en	Page 1/1

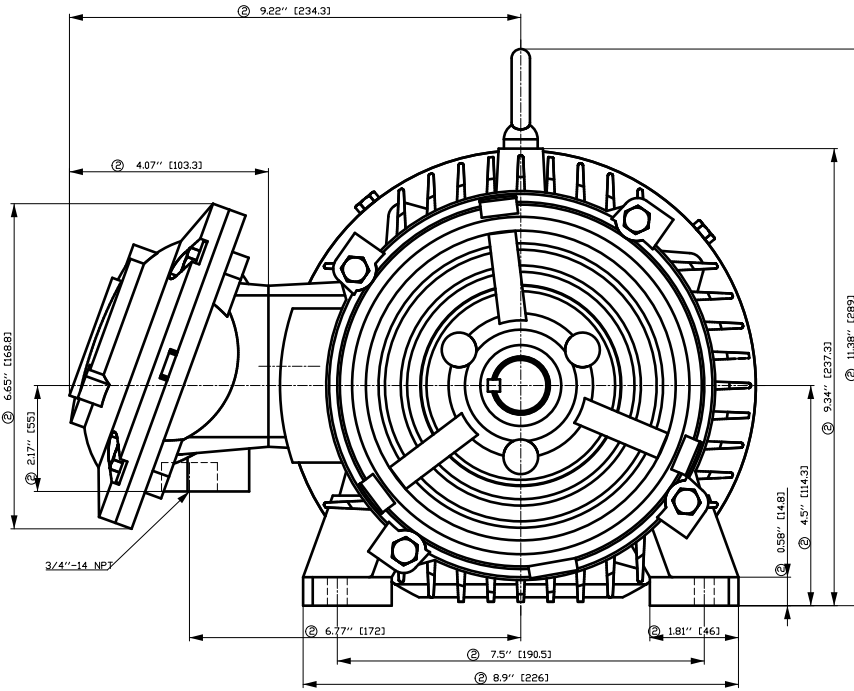

① Tolerances according to NEMA std.

② All these dimensions corresponding to assemblies and castings shall have a tolerance as per DIN standard 1686-GTB 19.

③ Not according to NEMA std.

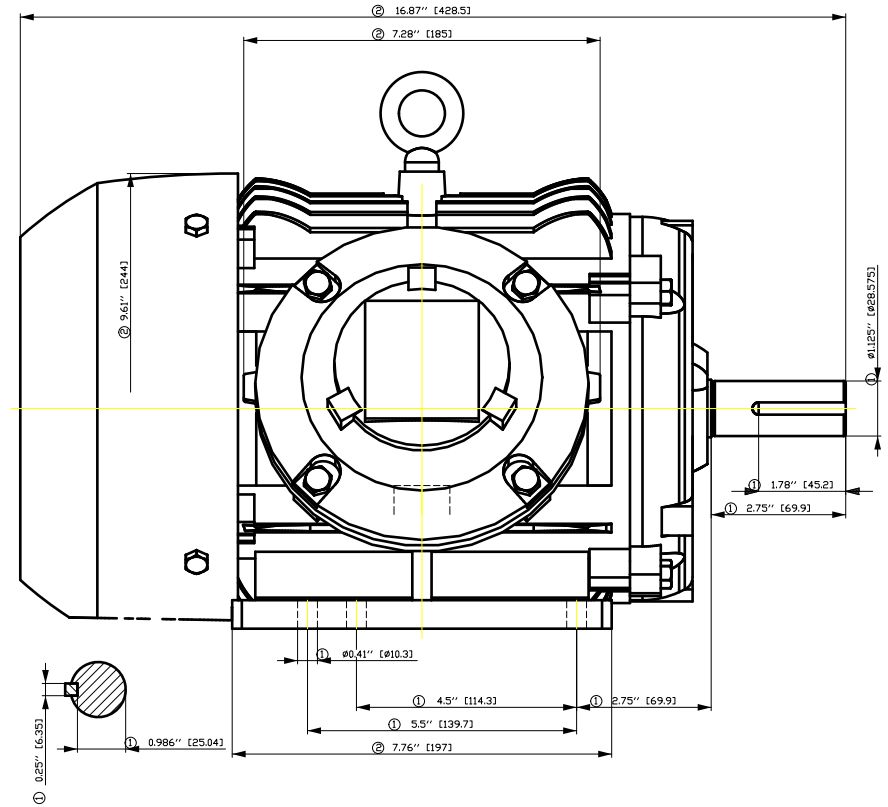

Tolerance	Surface	Material	Weight	Scale
FT ÖGF:FEÖÖFFB ÖDH	Author	ÖS T a: ^@~}*	E	
E	Creator			
	Approval			
	Department			
	Change Order	MFB	Doc Type	
	Doc. State	I ð BGG	Item No	Paper Size
	Revision	Index RS	Doc No	1st Language
				2nd Language
© Siemens AG 2018	Project No	E	Ref No	E
				Sheet F of F

Main terminal diagram



9 LEAD WYE						
Volts	LINES			CONNECTED TOGETHER	CONN.	
	L1	L2	L3			
LOW	T1 T7	T2 T6	T3 T9	T4 T5 T6	YY	
HIGH	T1	T2	T3	T4 T7-T5 T8-T6 T9	Y	

Motor protection

THERMOSTATS

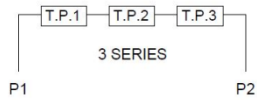

responsible dep. DI MC LVM	technical reference	created by	approved by	Project
<b>SIEMENS</b>	document type Wiring Diagram	document status free		customer
	title 1MB2121-1CD11-4AG3	document number		
© Siemens AG 2019	rev. 01	creation date 12/03/2019	language en	Page 1/1

# SIEMENS INDUSTRY, INC.

HP 1 VOLTS <600 RPM 900 TYPE XP100  
HZ 60 PHASE 3 FRAME 182T NEMA B

## TORQUE & CURRENT VS. SPEED

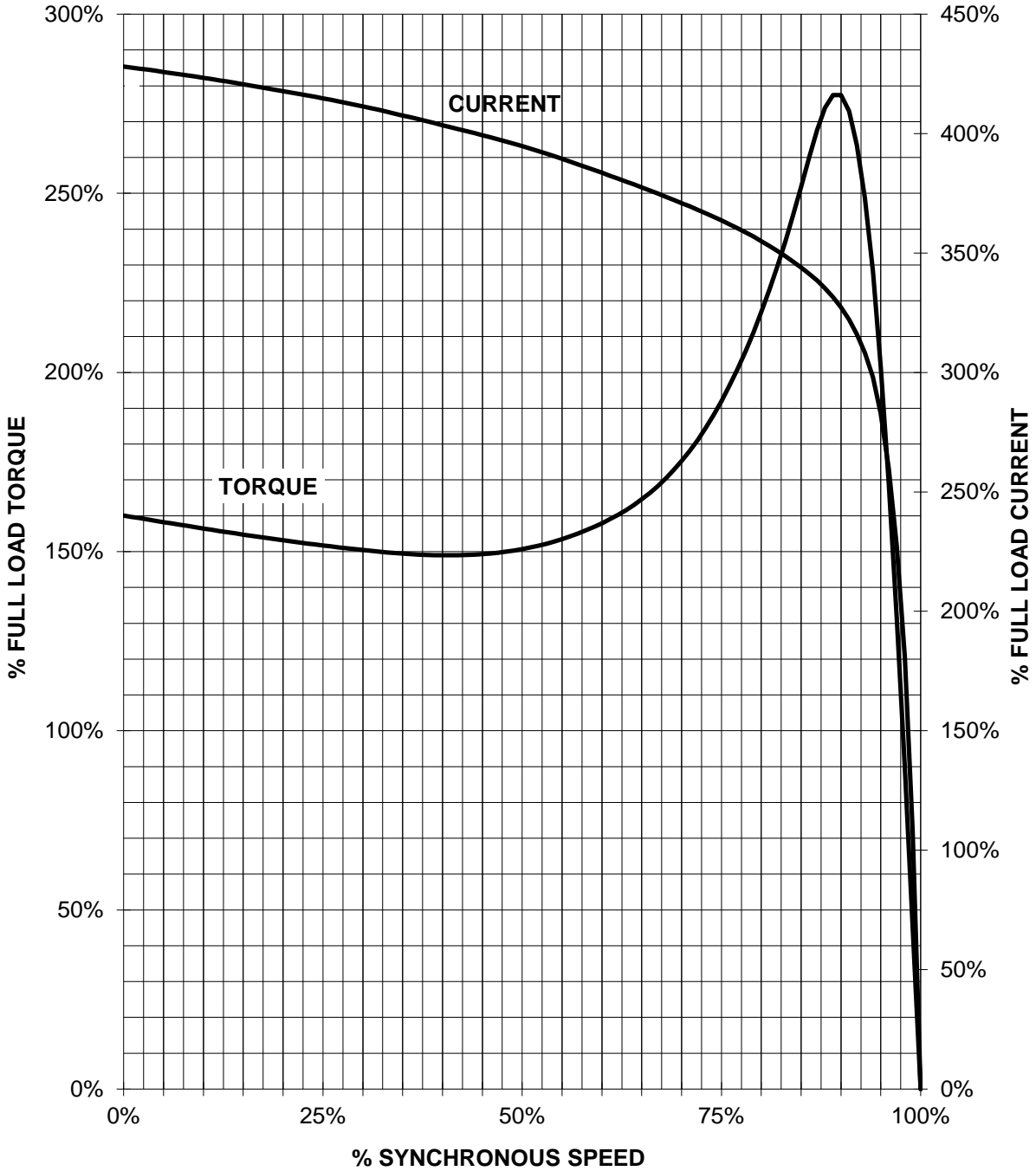

CUSTOMER: \_\_\_\_\_ ORDER#: \_\_\_\_\_

1 HP 900 RPM 182T FRAME 460 VOLTS 3 PHASE NEMA DESIGN B

**SIEMENS INDUSTRY, INC.  
PERFORMANCE CURVE  
XP100**

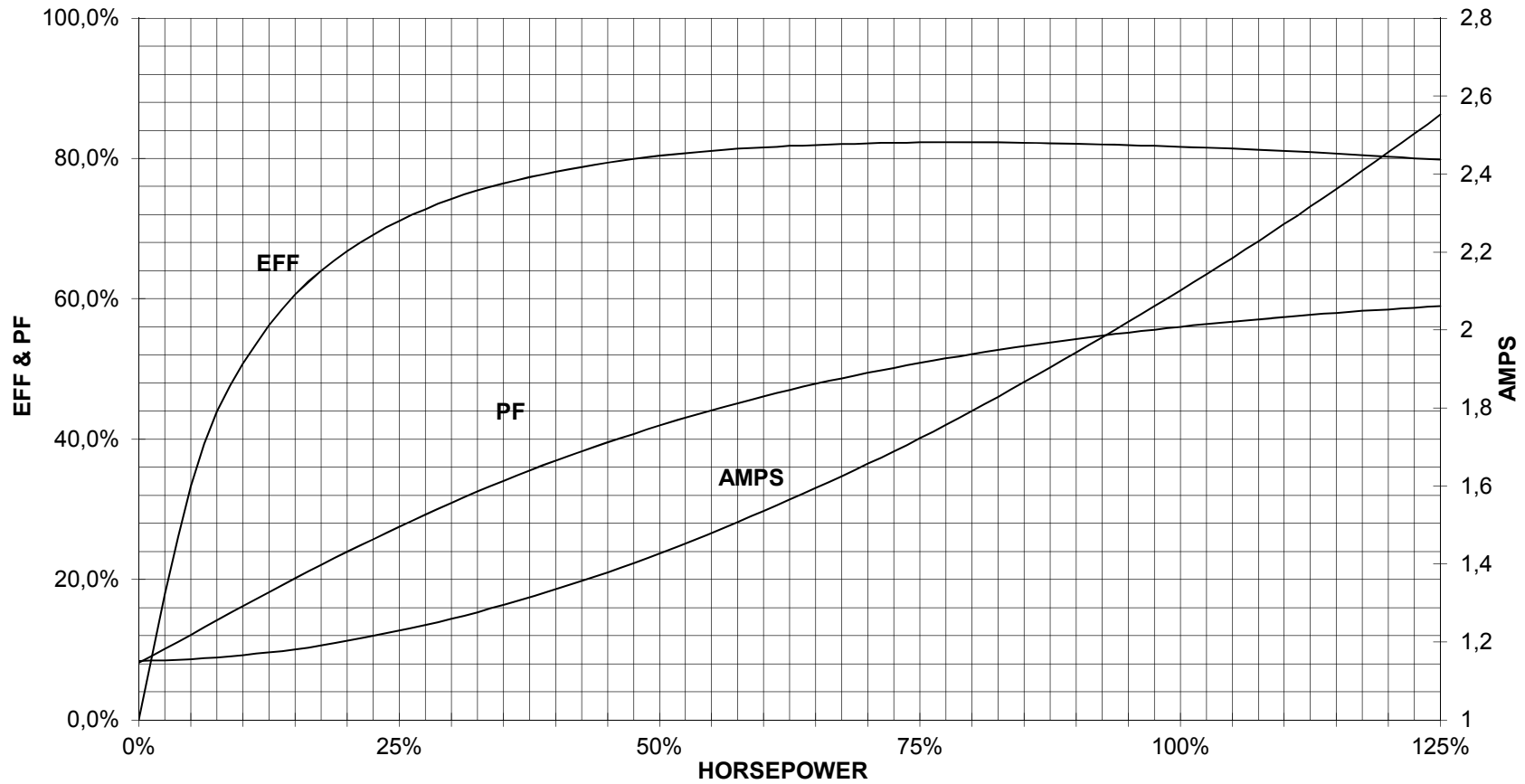

CUSTOMER \_\_\_\_\_ ORDER # \_\_\_\_\_ PO # \_\_\_\_\_

PERFORMANCE BASED ON DESIGN CALCULATIONS. SUBJECT TO CHANGE WITHOUT NOTICE.

REV. 1