

Data sheet for three-phase Squirrel-Cage-Motors SIMOTICS

Motor type: FS: 213T - 8p - 2 hp -

Client order no.	Item-No.	Offer no.
Order no.	Consignment no.	Project

Remarks

Electrical data Class I, Div 1 Gr. C&D; Class II, Div1, Gr. F&G

U [V]	Δ/Y	f [Hz]	P [HP]	P [kW]	n [rpm]	I Load [Amps]					LRC	Nom. Eff Load [%]			Pwr. Factor Load [%]			Torque [lb-ft]	T _A /T _N LRT [%]	T _k /T _N BDT [%]
						4/4	3/4	1/2	0	4/4		3/4	2/4	4/4	3/4	2/4				
575		60	2.00	-/-	870	2.60	2.10	1.70	1.60	12.8	84.0	84.5	84.0	67.0	63.0	51.0	16.0	175	262	

Frame Type: 213T	Type of constr.: (A) Foot mounted - End shield	Ins. Cl.: Insulation class F	Motor Prot.: (G) Thermostats, Klixon type, normally closed	NEMA Des.: B	S.F.: 1.15
Mtr. WT: 161		Temp. Rise Cl.: B	Amb. Temp.: + to -20 °C @1000 m	kVA: H	IP IP65

Mechanical data

Sound level (SPL / SWL) at 60 Hz	64.0 dB(A) / 71.0 dB(A)	Thickener	Polyurea
Octave Band Center Frequencies Hertz	250 500 1000 2000 4000 8000 Hz	Safe Stall Time Hot	22 s
SPL@3		Safe Stall Time Cold	38 s
Moment of inertia	0.5 Lb-ft ²	Frame material	cast iron
Ext Load Inertia Capability:	60.0 Lb ft ²	Color, paint shade	
Bearings		Coating (paint finish)	
Bearing DE NDE	6208 Z C3 S0 6208 Z C3 S0	Ventilation Type	
Bearing_Type	Ball Bearing Ball Bearing	Method of cooling	TEFC
AFBMA:	40BC02JP30 40BC02JP30	Direction of rotation	Bidirectional
Grease		Fan Material	Polypropylen ESD
Capacity	0.3 oz 0.3 oz	VFD	CT: 4:1 VT: 20:1
Grease Type:	Exxon Mobile EM	Space heaters	without
		Brake:	-/-

Terminal box

Lead Wire Connection	3 LEAD - WYE	Terminal box position	(3) Mounting - F-1
Voltage	L1 L1 L1 Connected together	Material of terminal box	
----	----	Cable entry	-/-
----	T1 T2 T3		

Notes:
 I_r/I_N = locked rotor current / current nominal
 M_r/M_N = locked rotor torque / torque nominal
 M_b/M_N = break down torque / nominal torque
 3) Value is valid only for DOL operation with motor design IC411
 2) at rated power / at full load

responsible dep. DI MC LVM	technical reference	created by DT Configurator	approved by	<i>Technical data are subject to change! There may be discrepancies between software and hardware versions.</i>
-------------------------------	---------------------	-------------------------------	-------------	-----------------------------------------------------------------------------------------------------------------

	document type datasheet	document status released	customer	
	title 1MB2121-2AD11-3AG3	document number		
© Siemens AG 2022	rev. 01	creation date 2022-04-08 18:56	language en	Page 1/1

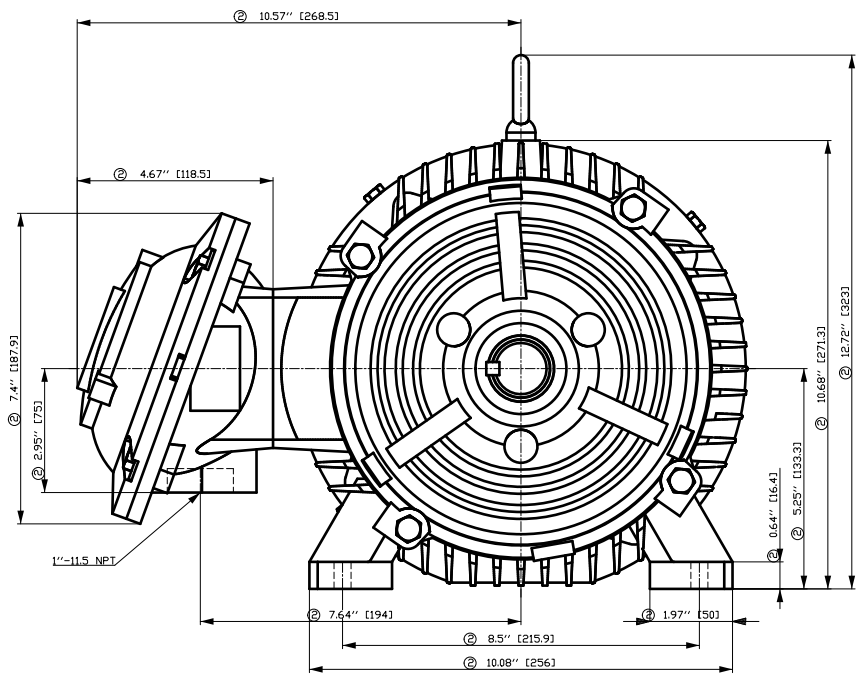

- ① Tolerances according to NEMA std.
- ② All these dimensions corresponding to assemblies and castings shall have a tolerance as per DIN standard 1686-GTB 19.
- ③ Not according to NEMA std.

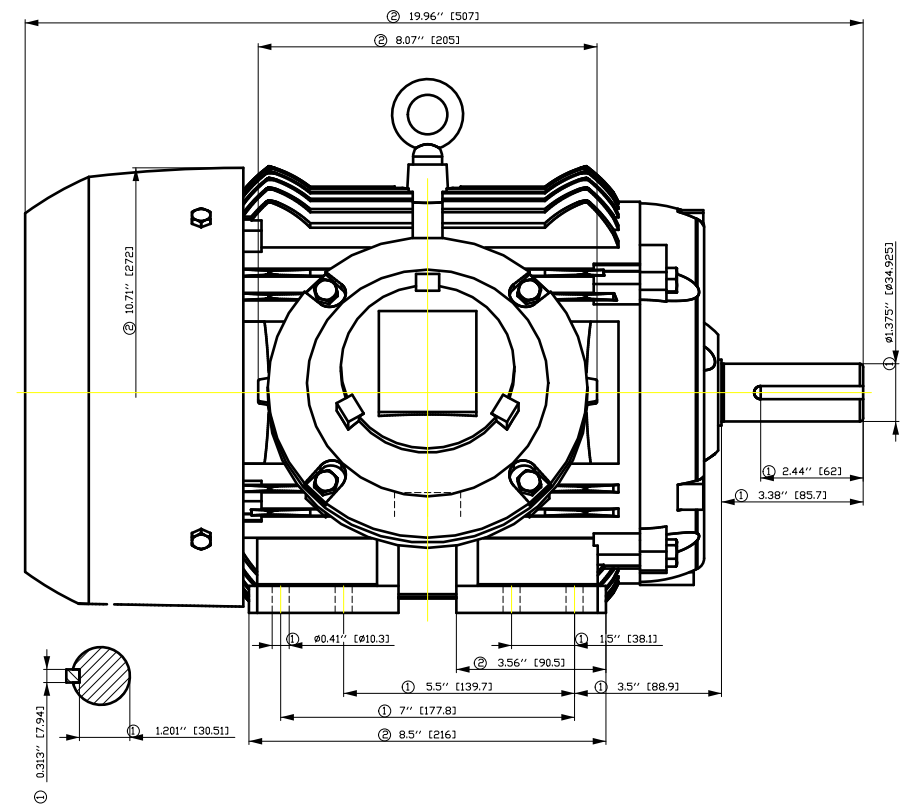

刀线管
 用文全
 积
 01
 02
 03
 04
 05
 06
 07
 08
 09
 10
 11
 12
 13
 14
 15
 16
 17
 18
 19
 20
 21
 22
 23
 24
 25
 26
 27
 28
 29
 30
 31
 32
 33
 34
 35
 36
 37
 38
 39
 40
 41
 42
 43
 44
 45
 46
 47
 48
 49
 50
 51
 52
 53
 54
 55
 56
 57
 58
 59
 60
 61
 62
 63
 64
 65
 66
 67
 68
 69
 70
 71
 72
 73
 74
 75
 76
 77
 78
 79
 80
 81
 82
 83
 84
 85
 86
 87
 88
 89
 90
 91
 92
 93
 94
 95
 96
 97
 98
 99
 100

Tolerance	Surface	Material	Weight	Scale
FT ÖGFC EÖFFH ÖÖH	Author	ÖS T a : ^ @ } *	E	
E	Creator			
	Approval			
	Department			
	Change Order	MFB	Doc Type	/
	Doc. State	I ÖB ÖG	Item No	Paper Size
	Revision	Index RS	Doc No	1st Language
				2nd Language
© Siemens AG 2018	Project No	E	Ref No	E
				Sheet F of F

Main terminal diagram

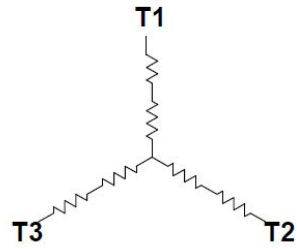

3 LEAD WYE			
LINES			CONN.
L1	L2	L3	
T1	T2	T3	Y

Motor protection

THERMOSTATS



responsible dep.
DI MC LVM

technical reference

created by

approved by

Project

SIEMENS

document type
Wiring Diagram

title
1MB2121-2AD11-3AG3

document status
free

document number

customer

SIEMENS INDUSTRY, INC.

HP 2 VOLTS <600 RPM 900 TYPE XP100
HZ 60 PHASE 3 FRAME 213T NEMA B

TORQUE & CURRENT VS. SPEED

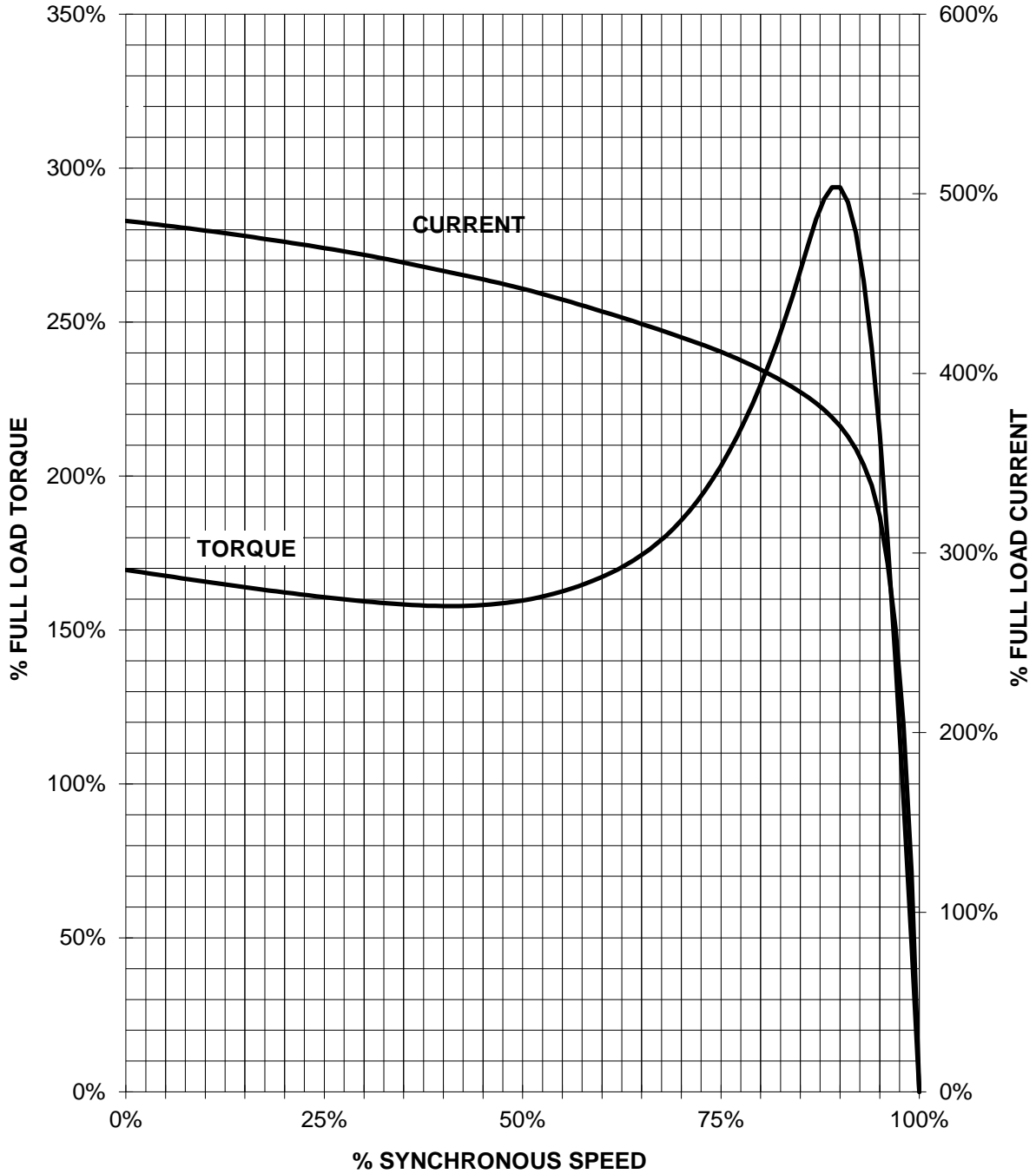

CUSTOMER: _____ ORDER#: _____

2 HP 900 RPM 213T FRAME 575 VOLTS 3 PHASE NEMA DESIGN B

SIEMENS INDUSTRY, INC.
PERFORMANCE CURVE
XP100

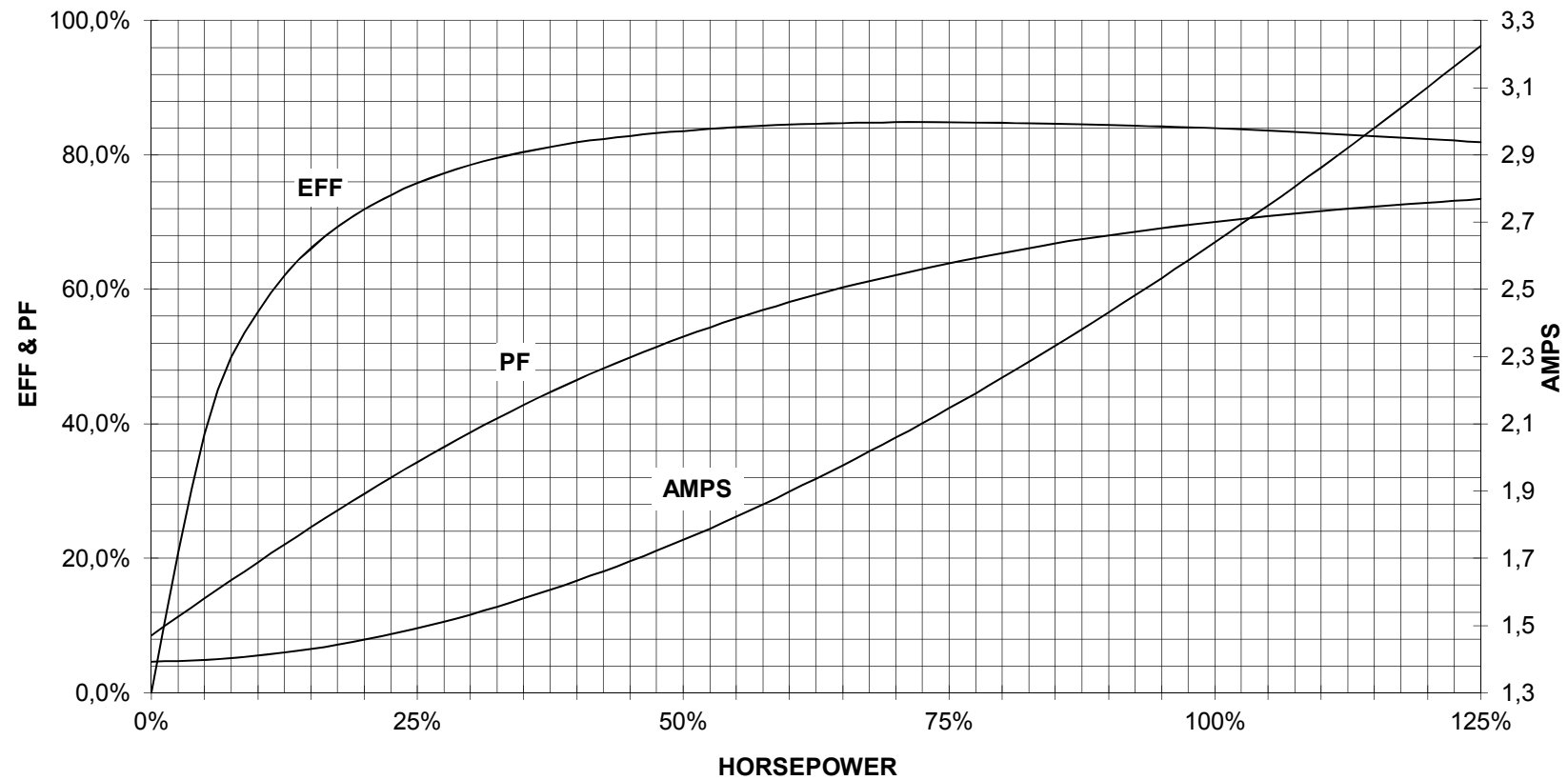

CUSTOMER _____ ORDER # _____ PO # _____

PERFORMANCE BASED ON DESIGN CALCULATIONS. SUBJECT TO CHANGE WITHOUT NOTICE.

REV. 1