

Data sheet for three-phase Squirrel-Cage-Motors SIMOTICS

Motor type: FS: 284TS - 2p - 25 hp -

Client order no.	Item-No.	Offer no.
Order no.	Consignment no.	Project
Remarks		

Electrical data Class I, Div 1 Gr. C&D; Class II, Div1, Gr. F&G

U [V]	Δ/Y	f [Hz]	P [HP]	P [kW]	n [rpm]	I Load [Amps]					LRC	Nom. Eff Load [%]			Pwr. Factor Load [%]			Torque [lb-ft]	T _A /T _N LRT [%]	T _k /T _N BDT [%]
						4/4	3/4	1/2	0	4/4		3/4	2/4	4/4	3/4	2/4				
575		60	25.00	-/-	3,525	23.20	17.70	12.60	5.60	146.4	91.7	92.2	91.4	88.0	86.0	81.0	37.0	159	251	

Frame Type: 284TS	Type of constr.: (A) Foot mounted - End shield	Ins. Cl.:Insulation class F	Motor Prot.:(G) Thermostats, Klixon type, normally closed	NEMA Des.: B	S.F.: 1.15
Mtr. WT:526		Temp. Rise Cl.: B	Amb. Temp.: + to -20 °C @1000 m	kVA: G	IP IP65

Mechanical data

Sound level (SPL / SWL) at 60 Hz	72.0 dB(A) / 83.0 dB(A)	Thickener	Polyurea
Octave Band Center Frequencies Hertz	250 500 1000 2000 4000 8000 Hz	Safe Stall Time Hot	16 s
SPL@3	dB(A)	Safe Stall Time Cold	30 s
Moment of inertia	3.1 Lb-ft ²	Frame material	cast iron
Ext Load Inertia Capability:	26.0 Lb ft ²	Color, paint shade	
Bearings		Coating (paint finish)	
Bearing DE NDE	6310 Z C3 S0 6310 Z C3 S0	Ventilation Type	
Bearing_Type	Ball Bearing Ball Bearing	Method of cooling	TEFC
AFBMA:	50BC03JP30 50BC03JP30	Direction of rotation	Bidirectional
Grease		Fan Material	Polypropylen ESD
Capacity	2.6 oz 2.6 oz	VFD	CT: 4:1 VT: 20:1
Grease Type:	Exxon Mobile EM	Space heaters	without
		Brake:	-/-

Terminal box

Lead Wire Connection	3 LEAD - DELTA	Terminal box position	(3) Mounting - F-1
Voltage	L1 L1 L1 Connected together	Material of terminal box	
----	----	Cable entry	-/-
----	T1 T2 T3		

Notes:			
I _r /I _N = locked rotor current / current nominal	M _r /M _N = locked rotor torque / torque nominal	M _b /M _N = break down torque / nominal torque	3) Value is valid only for DOL operation with motor design IC411 2) at rated power / at full load

responsible dep. DI MC LVM	technical reference	created by DT Configurator	approved by	<i>Technical data are subject to change! There may be discrepancies between software and hardware versions</i>			
	document type datasheet	document status released	customer				
	title 1MB2121-2DA11-3AG3	document number					
© Siemens AG 2022		rev. 01	creation date 2022-04-08 21:01	language en	Page 1/1		

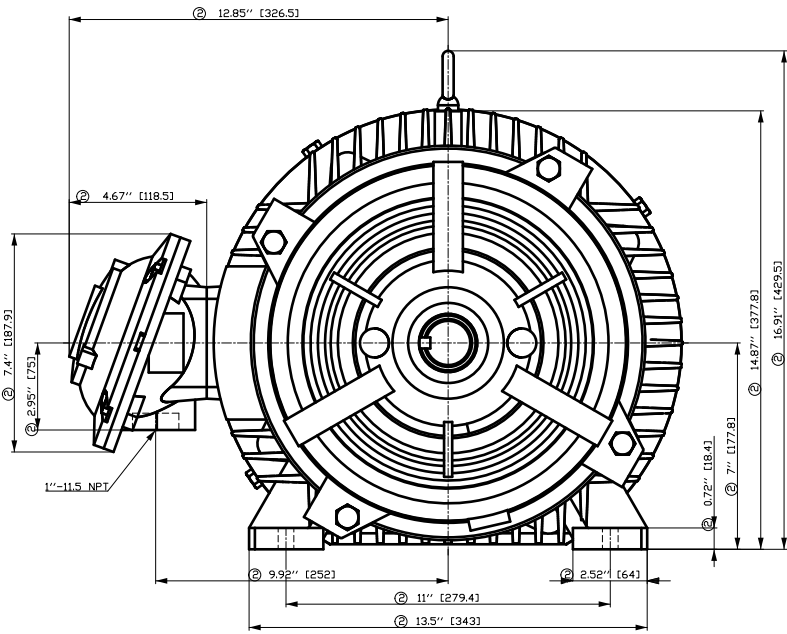

- ① Tolerances according to NEMA std.
- ② All these dimensions corresponding to assemblies and castings shall have a tolerance as per DIN standard 1686-GTB 19.
- ③ Not according to NEMA std.

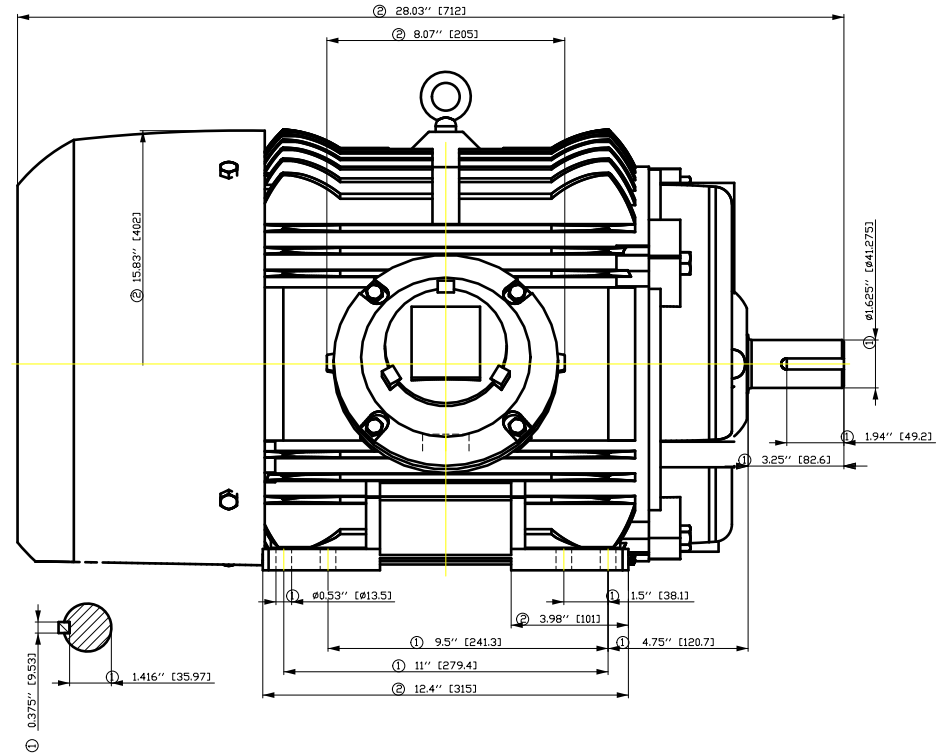

Tolerance	Surface	Material	Weight	Scale
FT ÖGFC EÖÖFF EÖÖH	Author	ÖB ^} • 4 } 2/4/2 3 *	E	{ {
E	Creator	ÖVS		
	Approval	T æ : ^ 2 @ } *		
	Department			
	Change Order	MFB		Doc Type
	Doc. State	I B ÖG		Paper Size
	Revision	Index RS		1st Language ^}
				2nd Language a^
© Siemens AG 2018	Project No	E	Ref No	E
				Sheet
				F of F

Main terminal diagram

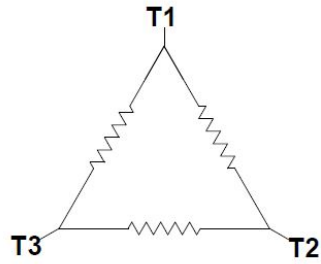

3 LEAD DELTA			
LINES			CONN.
L1	L2	L3	
T1	T2	T3	Δ

Motor protection

THERMOSTATS



responsible dep.
DI MC LVM

technical reference

created by

approved by

Project

SIEMENS

document type
Wiring Diagram

title
1MB2121-2DA11-3AG3

document status
free

document number

customer

SIEMENS INDUSTRY, INC.

HP 25 VOLTS <600 RPM 3600 TYPE XP100
HZ 60 PHASE 3 FRAME 284TS NEMA B

TORQUE & CURRENT VS. SPEED

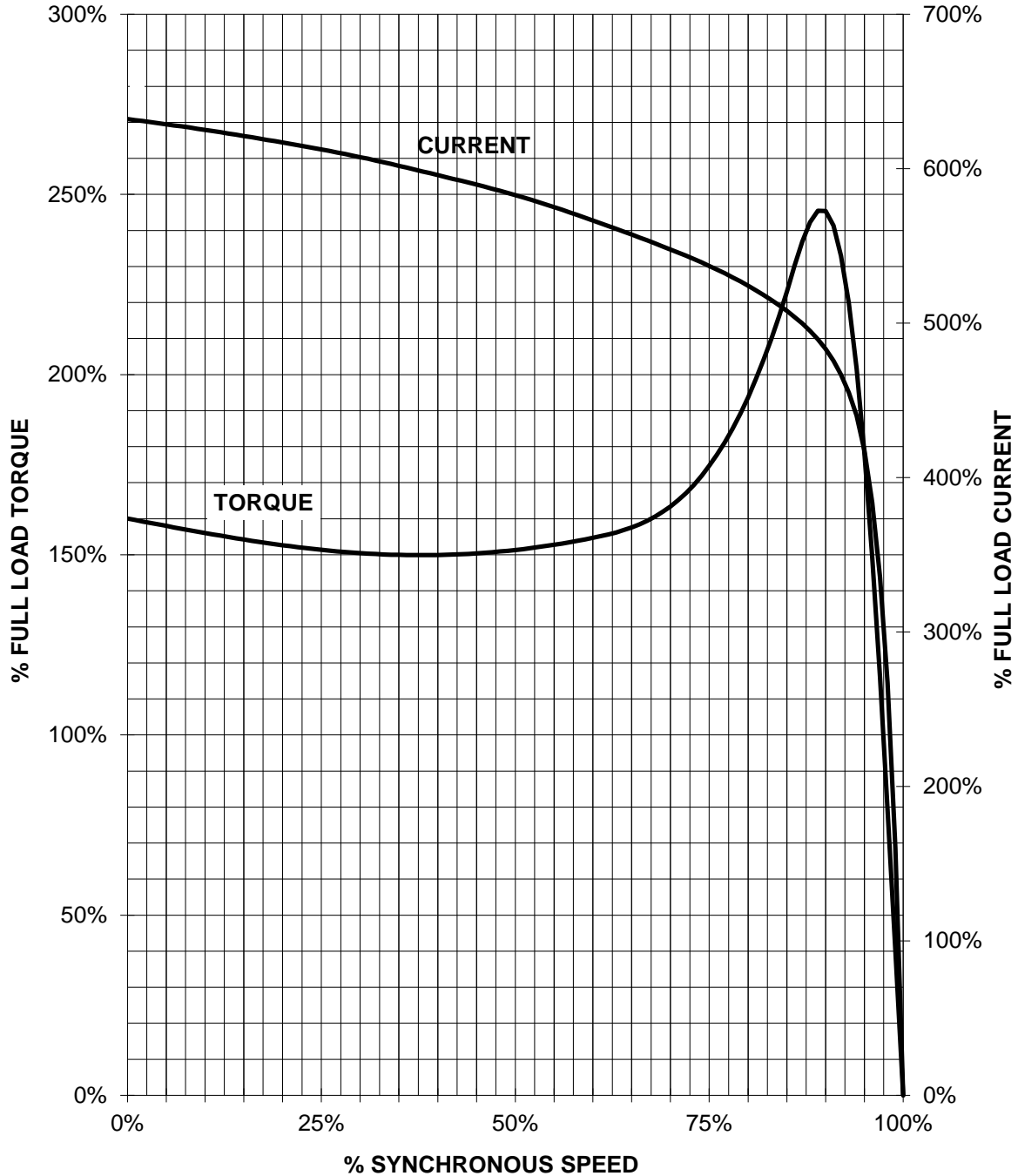

CUSTOMER: _____ ORDER#: _____

25 HP 3600 RPM 284TS FRAME 575 VOLTS 3 PHASE NEMA DESIGN B

SIEMENS INDUSTRY, INC.
PERFORMANCE CURVE
XP100

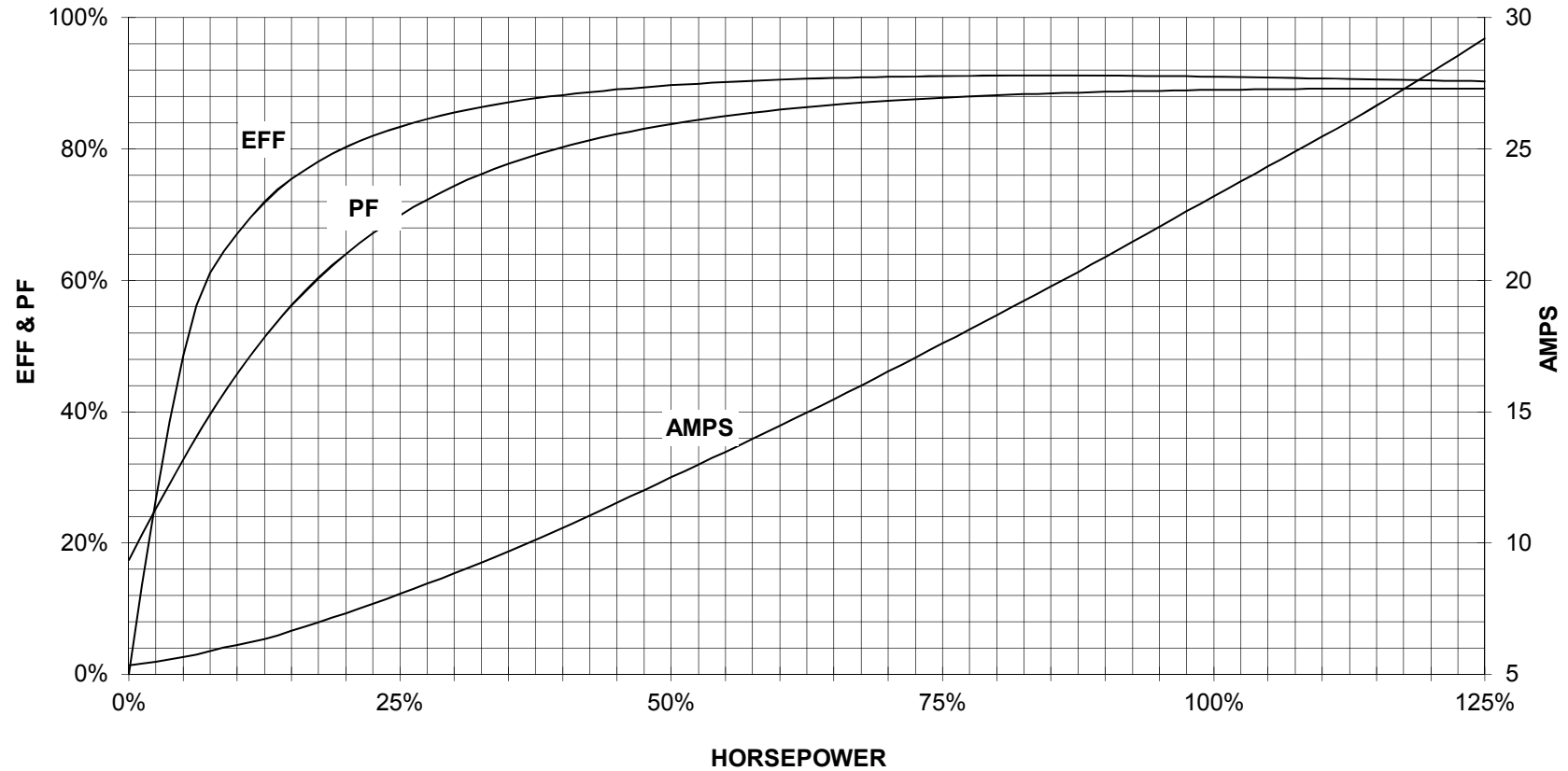

CUSTOMER _____ ORDER # _____ PO # _____

PERFORMANCE BASED ON DESIGN CALCULATIONS. SUBJECT TO CHANGE WITHOUT NOTICE.

REV. 1