

Data sheet for three-phase Squirrel-Cage-Motors SIMOTICS

Motor type: FS: 365T - 4p - 75 hp -

Client order no.	Item-No.	Offer no.
Order no.	Consignment no.	Project

Remarks

Electrical data Class I, Div 1 Gr. C&D; Class II, Div1, Gr. F&G

U [V]	Δ/Y	f [Hz]	P [HP]	P [kW]	n [rpm]	I Load [Amps]					LRC	Nom. Eff Load [%]			Pwr. Factor Load [%]			Torque [lb-ft]	T _A /T _N LRT [%]	T _k /T _N BDT [%]
						4/4	3/4	1/2	0			4/4	3/4	2/4	4/4	3/4	2/4			
575		60	75.00	-/-	1,780	68.00	51.70	37.70	20.00	434.4	95.4	95.8	95.6	87.0	85.0	78.0	221.0	180	240	

Frame Type: 365T	Type of constr.: (A) Foot mounted - End shield	Ins. Cl.:Insulation class F	Motor Prot.:(G) Thermostats, Klixon type, normally closed	NEMA Des.: B	S.F.: 1.15
Mtr. WT:947		Temp. Rise Cl.: B	Amb. Temp.: + to -20 °C @1000 m	kVA: G	IP IP65

Mechanical data

Sound level (SPL / SWL) at 60 Hz	64.0 dB(A) / 75.0 dB(A)	Thickener	Polyurea
Octave Band Center Frequencies Hertz	250 500 1000 2000 4000 8000 Hz	Safe Stall Time Hot	25 s
SPL@3		Safe Stall Time Cold	35 s
Moment of inertia	19.8 Lb-ft ²	Frame material	cast iron
Ext Load Inertia Capability:	338.0 Lb ft ²	Color, paint shade	
Bearings		Coating (paint finish)	
Bearing DE NDE	6314 Z C3 S0 6314 Z C3 S0	Ventilation Type	
Bearing_Type	Ball Bearing Ball Bearing	Method of cooling	TEFC
AFBMA:	70BC03JP30 70BC03JP30	Direction of rotation	Bidirectional
Grease		Fan Material	Polypropylen ESD
Capacity	7.5 oz 7.5 oz	VFD	CT: n/a VT: 20:1
Grease Type:	Exxon Mobile EM	Space heaters	without
		Brake:	-/-

Terminal box

Lead Wire Connection	3 LEAD - DELTA	Terminal box position	(3) Mounting - F-1
Voltage	L1 L1 L1 Connected together	Material of terminal box	
---	---	Cable entry	-/-
---	T1 T2 T3		

Notes:
 I_L/I_N = locked rotor current / current nominal
 M_L/M_N = locked rotor torque / torque nominal
 M_d/M_N = break down torque / nominal torque
 3) Value is valid only for DOL operation with motor design IC411
 2) at rated power / at full load

responsible dep. DI MC LVM	technical reference	created by DT Configurator	approved by	<i>Technical data are subject to change! There may be discrepancies between software and hardware versions.</i>
-------------------------------	---------------------	-------------------------------	-------------	---

	document type datasheet	document status released	customer		
	title 1MB2121-3CB21-3AG3	document number			
© Siemens AG 2022		rev. 01	creation date 2022-04-08 22:18	language en	Page 1/1

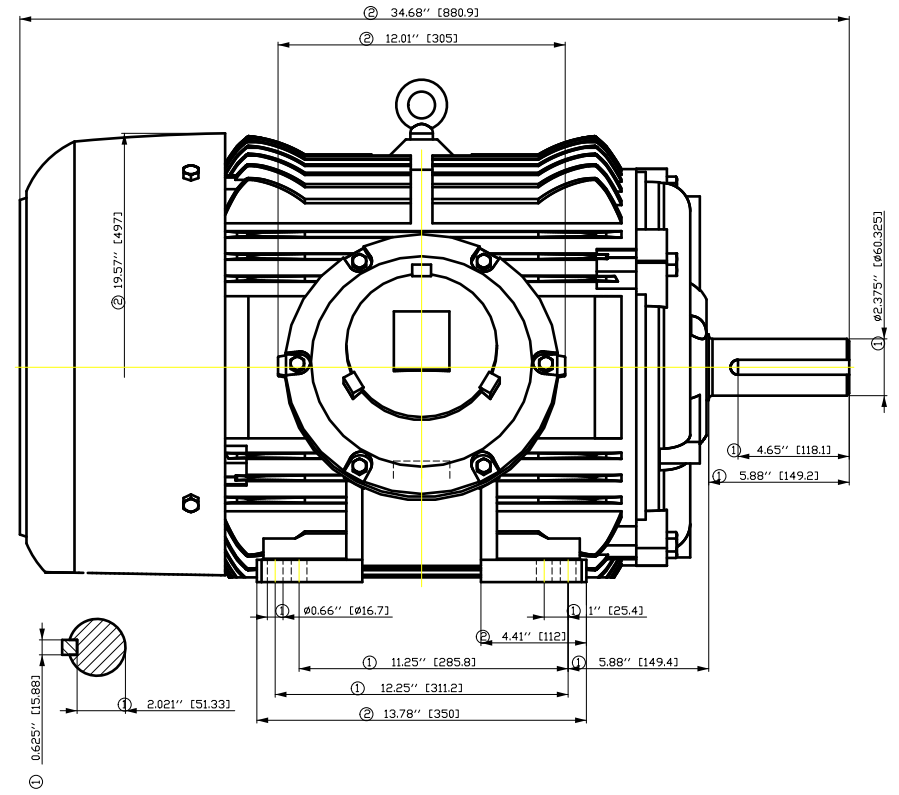
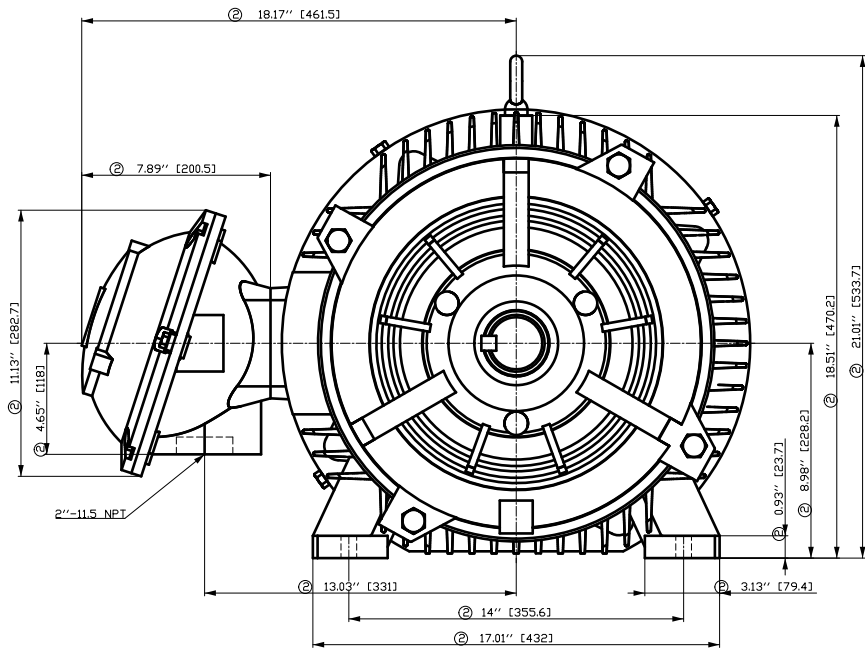

- ① Tolerances according to NEMA std.
- ② All these dimensions corresponding to assemblies and castings shall have a tolerance as per DIN standard 1686-GTB 19.
- ③ Not according to NEMA std.

Tolerance	Surface	Material	Weight	Scale
FT ÖGF:CF#ÖÖGF#ÖÖH É	Author Creator Approval Department Change Order	ÖS T æ : ^æ@` } *	É	{ {
SIEMENS	Doc. State	Item No	Doc Type	
	Revision	Index	Paper Size	
© Siemens AG	Project No	Ref No	1st Language	
2018	É	É	2nd Language	
			Sheet F of F	

Main terminal diagram

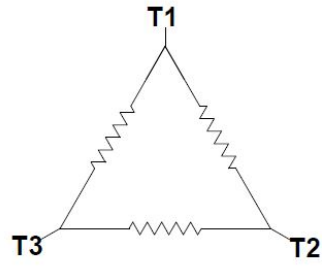

3 LEAD DELTA			
LINES			CONN.
L1	L2	L3	
T1	T2	T3	Δ

Motor protection

THERMOSTATS



responsible dep.
DI MC LVM

technical reference

created by

approved by

Project

SIEMENS

document type
Wiring Diagram

title
1MB2121-3CB21-3AG3

document status
free

document number

customer

SIEMENS INDUSTRY, INC.

HP 75 VOLTS <600 RPM 1800 TYPE XP100
HZ 60 PHASE 3 FRAME 365T NEMA B

TORQUE & CURRENT VS. SPEED

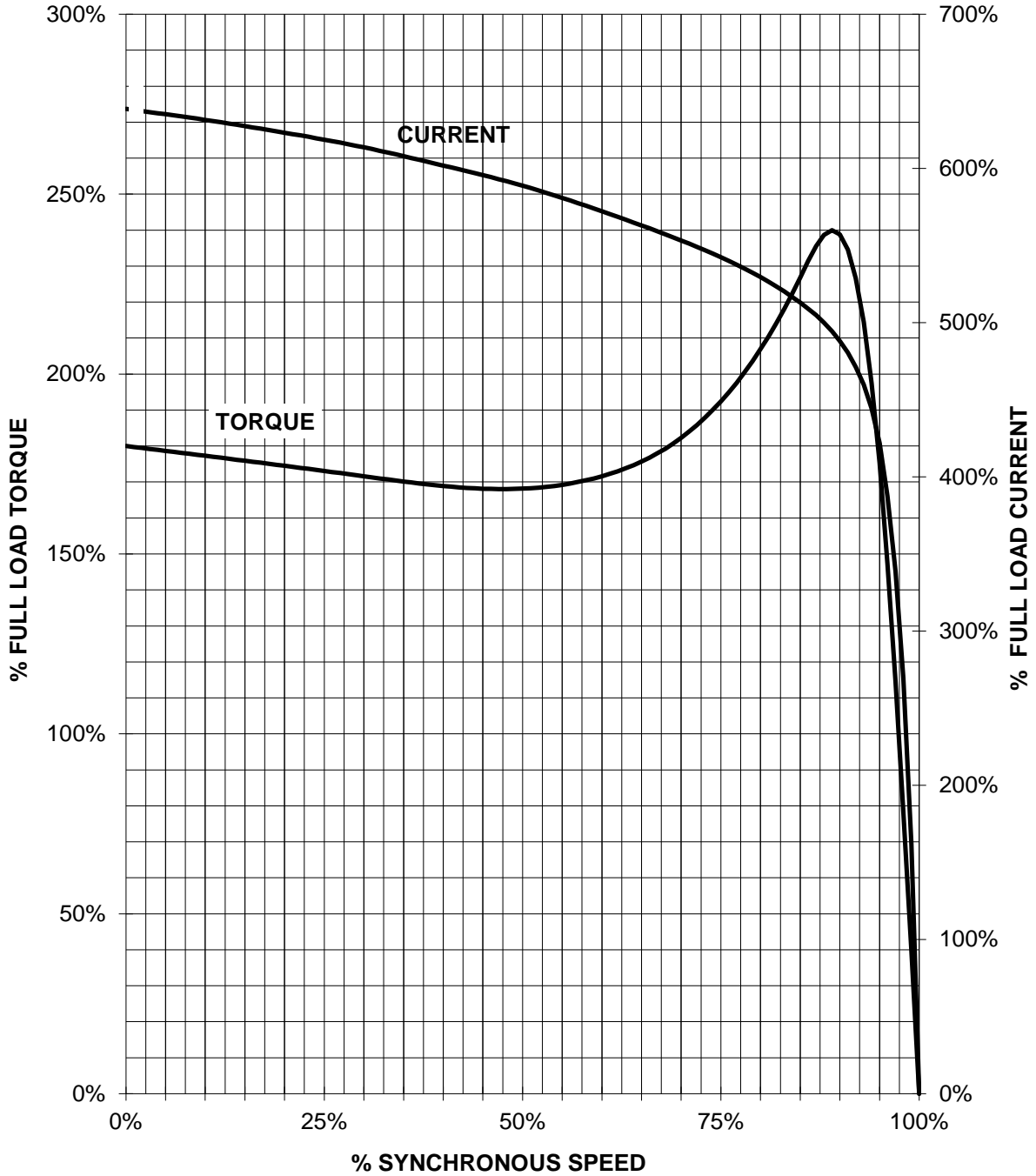

CUSTOMER: _____ ORDER#: _____

75 HP 1800 RPM 365T FRAME 575 VOLTS 3 PHASE NEMA DESIGN B

SIEMENS INDUSTRY, INC.
PERFORMANCE CURVE
XP100

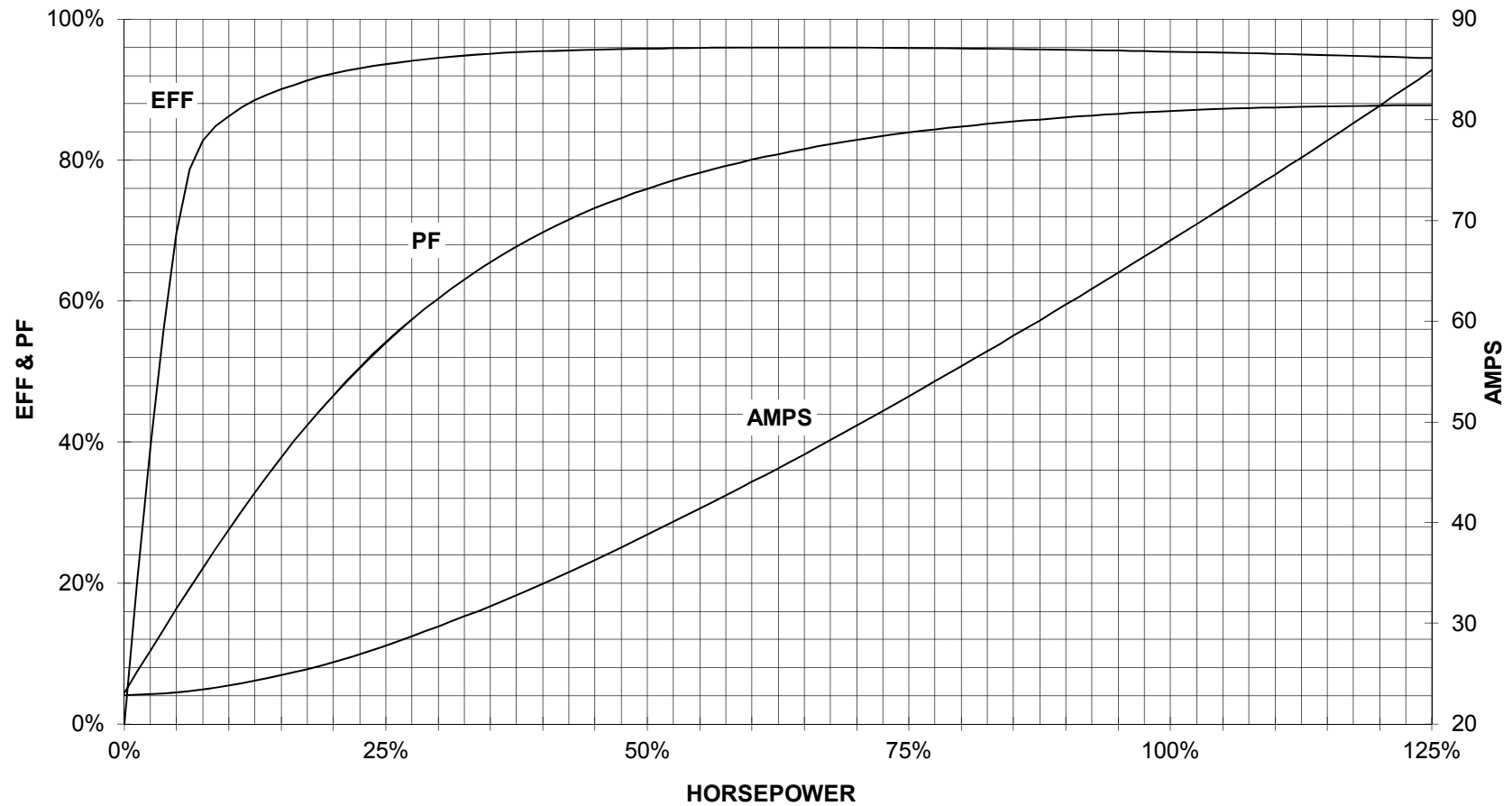

CUSTOMER _____ ORDER # _____ PO # _____

PERFORMANCE BASED ON DESIGN CALCULATIONS. SUBJECT TO CHANGE WITHOUT NOTICE.
REV. 1