

# Data sheet for three-phase Squirrel-Cage-Motors SIMOTICS

**Motor type:** FS: 447T - 6p - 150 hp -

Client order no.	Item-No.	Offer no.
Order no.	Consignment no.	Project
Remarks		

**Electrical data** Class I, Div 1 Gr. C&D; Class II, Div1, Gr. F&G

U [V]	$\Delta/Y$	f [Hz]	P [HP]	P [kW]	n [rpm]	I Load [Amps]					LRC	Nom. Eff Load [%]			Pwr. Factor Load [%]			Torque [lb-ft]	T <sub>A</sub> /T <sub>N</sub> LRT [%]	T <sub>k</sub> /T <sub>N</sub> BDT [%]
						4/4	3/4	1/2	0			4/4	3/4	2/4	4/4	3/4	2/4			
575		60	150.00	-/-	1,190	137.60	107.10	80.50	47.20	868.0	95.8	96.0	95.6	85.0	82.0	73.0	662.0	140	200	
Frame Type: 447T		Type of constr.: (A) Foot mounted - End shield				Ins. Cl.:Insulation class F		Motor Prot.:(G) Thermostats, Klixon type, normally closed				NEMA Des.: B		S.F.: 1.15						
Mtr. WT:2,051						Temp. Rise Cl.: B		Amb. Temp.: + to -20 °C @1000 m				kVA: G		IP IP65						

**Mechanical data**

Sound level (SPL / SWL) at 60 Hz	73.0 dB(A) / 84.0 dB(A)	Thickener	Polyurea
Octave Band Center Frequencies Hertz		Safe Stall Time Hot	28 s
250	500	1000	2000
4000	8000	Hz	
SPL@3	dB(A)		Safe Stall Time Cold
		Frame material	cast iron
Moment of inertia	68.6 Lb-ft <sup>2</sup>	Color, paint shade	
Ext Load Inertia Capability:	1720.0 Lb ft <sup>2</sup>	Coating (paint finish)	
<b>Bearings</b>		<b>Ventilation Type</b>	
Bearing DE   NDE	NU 320	6316 Z C3 S0	Method of cooling
Bearing_Type	Roller Bearing	Ball Bearing	TEFC
AFBMA:	100RU03M0	80BC03JP30	Direction of rotation
<b>Grease</b>			Bidirectional
Capacity	14.5 oz	7.5 oz	Fan Material
Grease Type:	Exxon Mobile EM		Polypropylen ESD
			VFD
			CT: n/a VT: 20:1
			Space heaters
			without
			Brake:
			-/-

**Terminal box**

Lead Wire Connection	6 LEAD - DELTA	Terminal box position	(3) Mounting - F-1
Voltage	L1	L1	L1
	Connected together	Material of terminal box	
----	----	Cable entry	-/-
----	T1	T2	T3
----	----		

**Notes:**

I<sub>r</sub>/I<sub>N</sub> = locked rotor current / current nominal  
M<sub>r</sub>/M<sub>N</sub> = locked rotor torque / torque nominal  
M<sub>b</sub>/M<sub>N</sub> = break down torque / nominal torque  
3) Value is valid only for DOL operation with motor design IC411  
2) at rated power / at full load

responsible dep. DI MC LVM	technical reference	created by DT Configurator	approved by	<i>Technical data are subject to change! There may be discrepancies between software and hardware versions</i>	
	document type datasheet	document status released	customer		
	title 1MB2121-4CC31-3AG3	document number			
© Siemens AG 2022	rev. 01	creation date 2022-04-09 02:00	language en	Page 1/1	

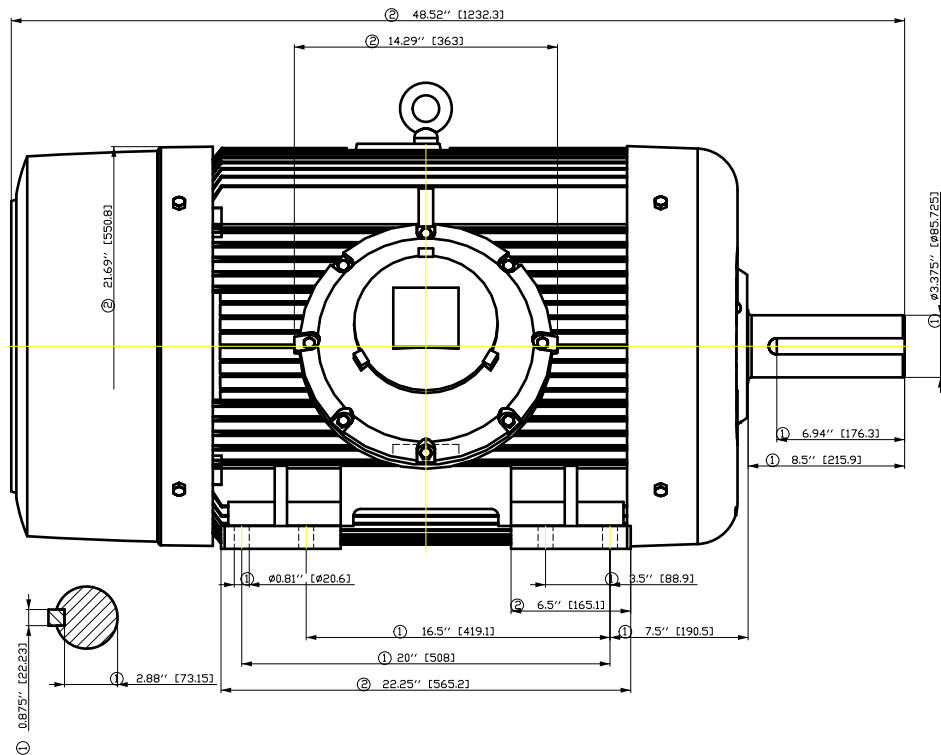
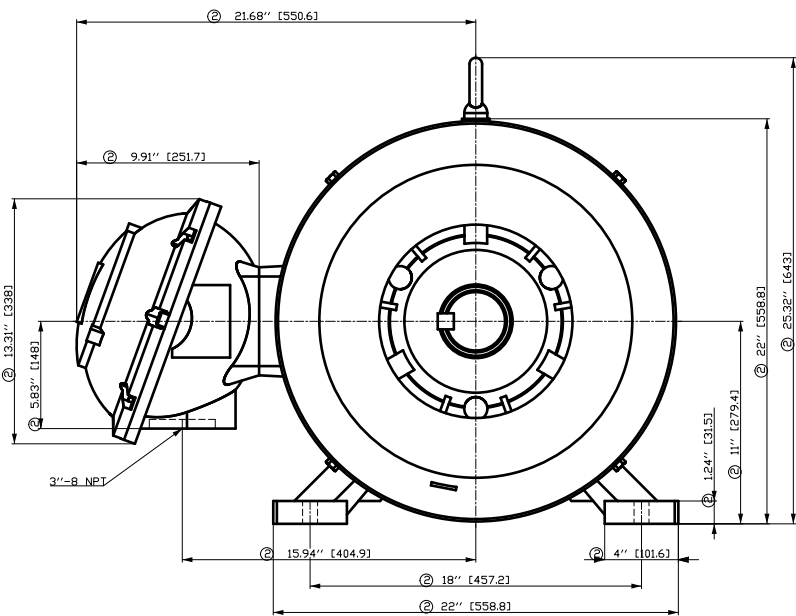

- ① Tolerances according to NEMA std.
- ② All these dimensions corresponding to assemblies and castings shall have a tolerance as per DIN standard 1686-GTB 19.
- ③ Not according to NEMA std.

Tolerance	Surface	Material	Weight	Scale
FT ÖGF C F# ÖÖHF# ÖÖH	Author	ÖS T æ : ^ æ @ } *	E	
E	Creator			
	Approval			
	Department	MLFB	Doc Type	/
	Change Order		Paper Size	CH
	Doc. State	I E B G G	Item No	
	Revision	Index RS	Doc No	1st Language ^
© Siemens AG 2018	Project No	E	Ref No	E
			Sheet	F of F

刀线管  
用转为  
英文  
标注  
积

刀线管  
用转为  
英文  
标注  
积

刀线管  
用转为  
英文  
标注  
积

刀线管  
用转为  
英文  
标注  
积

刀线管  
用转为  
英文  
标注  
积

Main terminal diagram

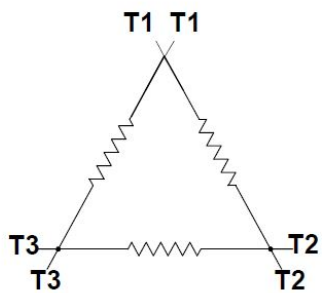

6 LEAD DELTA			
LINES			CONN.
L1	L2	L3	
T1	T2	T3	Δ

Motor protection

THERMOSTATS

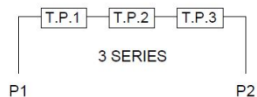

responsible dep.  
DI MC LVM

technical reference

created by

approved by

Project

**SIEMENS**

document type  
Wiring Diagram

title  
1MB2121-4CC31-3AG3

document status  
free

document number

customer

# SIEMENS INDUSTRY, INC.

HP 150 VOLTS <600 RPM 1200 TYPE XP100  
HZ 60 PHASE 3 FRAME 447T NEMA B

## TORQUE & CURRENT VS. SPEED

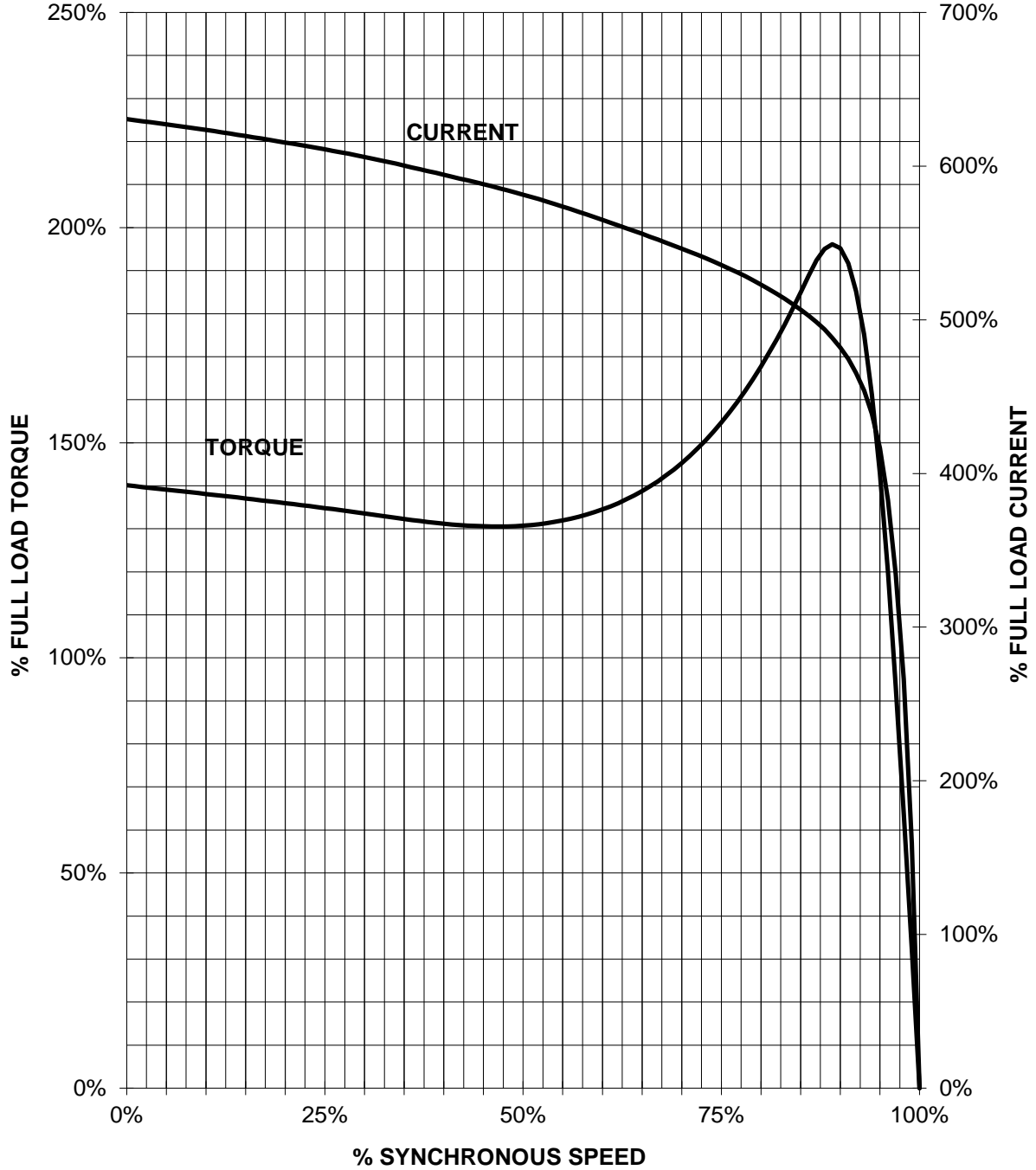

CUSTOMER: \_\_\_\_\_ ORDER#: \_\_\_\_\_

150 HP 1200 RPM 447T FRAME 575 VOLTS 3 PHASE NEMA DESIGN B

**SIEMENS INDUSTRY, INC.**  
**PERFORMANCE CURVE**  
**XP100**

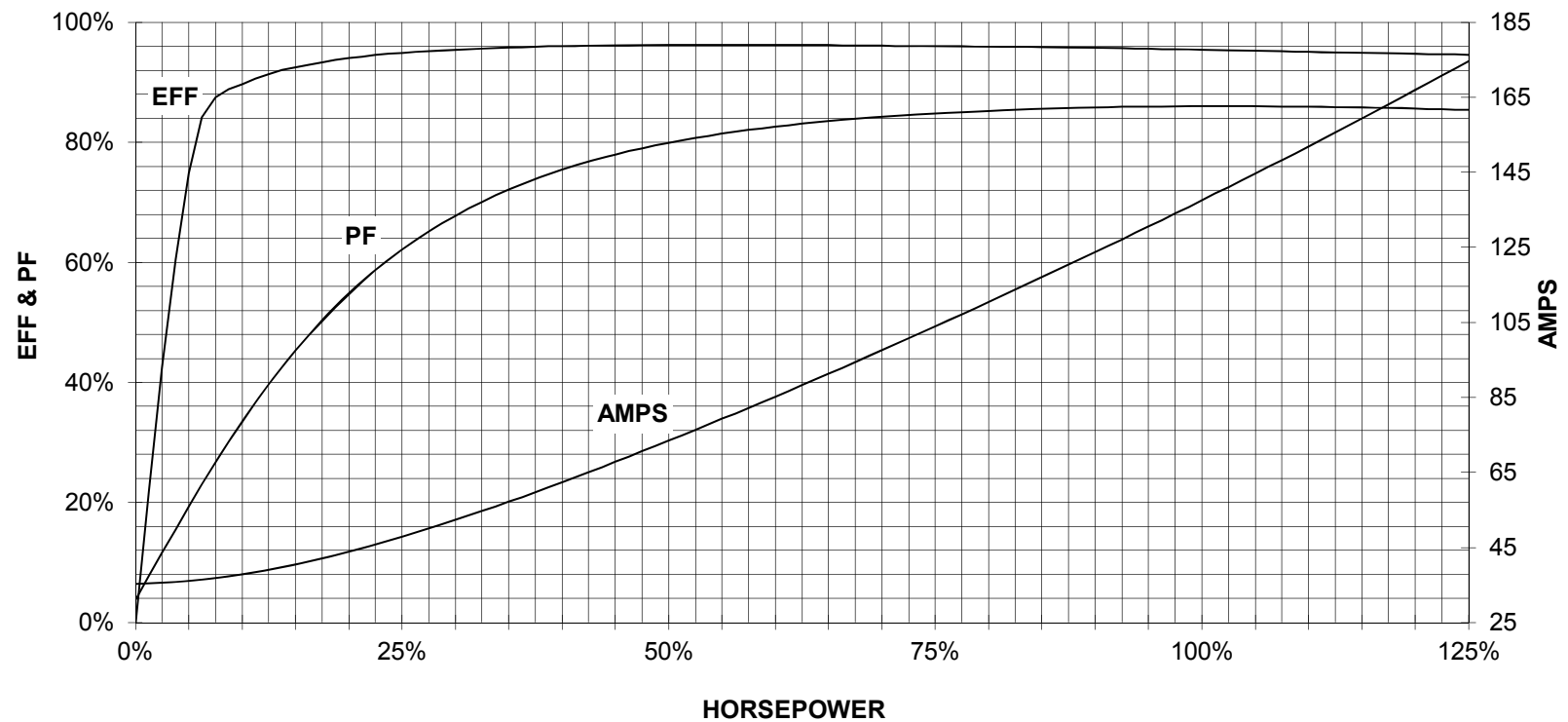

CUSTOMER \_\_\_\_\_ ORDER # \_\_\_\_\_ PO # \_\_\_\_\_

PERFORMANCE BASED ON DESIGN CALCULATIONS. SUBJECT TO CHANGE WITHOUT NOTICE.

REV. 1