

Data sheet for three-phase Squirrel-Cage-Motors SIMOTICS

Motor type: FS: 444T - 8p - 75 hp -

Client order no.	Item-No.	Offer no.
Order no.	Consignment no.	Project

Remarks

Electrical data Class I, Div 1 Gr. C&D; Class II, Div1, Gr. F&G

U [V]	Δ/Y	f [Hz]	P [HP]	P [kW]	n [rpm]	I Load [Amps]					LRC	Nom. Eff Load [%]			Pwr. Factor Load [%]			Torque [lb-ft]	T _A /T _N LRT [%]	T _k /T _N BDT [%]
						4/4	3/4	1/2	0			4/4	3/4	2/4	4/4	3/4	2/4			
460		60	75.00	-/-	885	94.00	73.80	56.10	37.00	543.0	93.6	93.9	93.5	80.0	76.0	67.0	445.0	135	200	
230		60	75.00	-/-	885	188.00					93.6	93.9	93.5	80.0	76.0	67.0	445.0	135	200	

Frame Type: 444T	Type of constr.: (A) Foot mounted - End shield	Ins. Cl.:Insulation class F	Motor Prot.:(G) Thermostats, Klixon type, normally closed	NEMA Des.: B	S.F.: 1.15
Mtr. WT:1,551		Temp. Rise Cl.: B	Amb. Temp.: + to -20 °C @1000 m	kVA: G	IP IP65

Mechanical data

Sound level (SPL / SWL) at 60 Hz	65.0 dB(A) / 76.0 dB(A)	Thickener	Polyurea
Octave Band Center Frequencies Hertz	250 500 1000 2000 4000 8000 Hz	Safe Stall Time Hot	25 s
SPL@3		Safe Stall Time Cold	32 s
Moment of inertia	40.0 Lb-ft ²	Frame material	cast iron
Ext Load Inertia Capability:	1810.0 Lb ft ²	Color, paint shade	
Bearings		Coating (paint finish)	
Bearing DE NDE	NU 318 6316 Z C3 S0	Ventilation Type	
Bearing_Type	Roller Bearing Ball Bearing	Method of cooling	TEFC
AFBMA:	90RU03M0 80BC03JP30	Direction of rotation	Bidirectional
Grease		Fan Material	Polypropylen ESD
Capacity	14.5 oz 7.5 oz	VFD	CT: n/a VT: 20:1
Grease Type:	Exxon Mobile EM	Space heaters	without
		Brake:	-/-

Terminal box

Lead Wire Connection	9 LEAD - DELTA	Terminal box position	(3) Mounting - F-1
Voltage	L1 L1 L1 Connected together	Material of terminal box	
LOW	T1 T7 T6 T2 T8 T4 T3 T9 T5	Cable entry	-/-
HIGH	T1 T2 T3 T4 T7-T5 T8-T6 T9		

Notes:
 I_L/I_N = locked rotor current / current nominal
 M_L/M_N = locked rotor torque / torque nominal
 M_d/M_N = break down torque / nominal torque
 3) Value is valid only for DOL operation with motor design IC411
 2) at rated power / at full load

responsible dep. DI MC LVM	technical reference	created by DT Configurator	approved by	<i>Technical data are subject to change! There may be discrepancies between software and hardware versions</i>
-------------------------------	---------------------	-------------------------------	-------------	--

	document type datasheet	document status released	customer	
	title 1MB2121-4CD11-6AG3	document number	rev. 01	creation date 2022-04-09 02:01
© Siemens AG 2022				Page 1/1

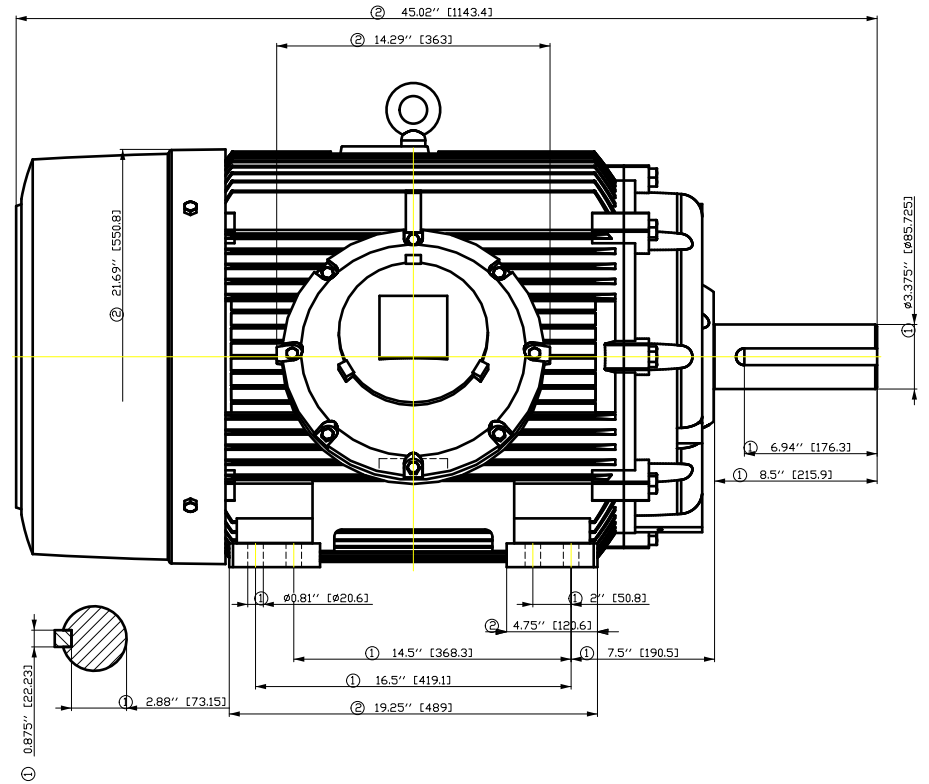
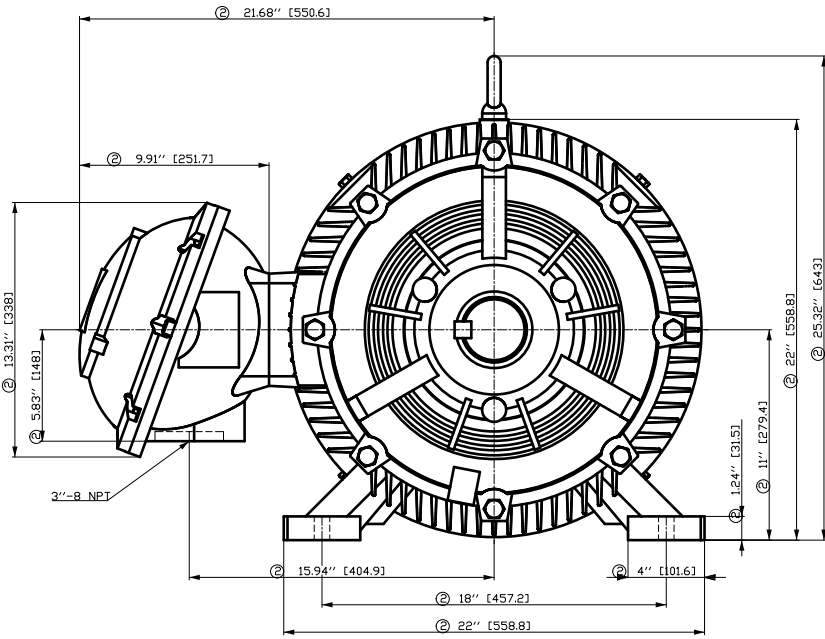

- ① Tolerances according to NEMA std.
- ② All these dimensions corresponding to assemblies and castings shall have a tolerance as per DIN standard 1686-GTB 19.
- ③ Not according to NEMA std.

Tolerance	Surface	Material	Weight	Scale
FT ÖGF:FF ÖÖFF:FF ÖÖH	Author	ÖS T: 1.2.2018	E	
E	Creator			
	Approval			
	Department			
	Change Order	MFB	Doc Type	/
	Doc. State	I EEEG	Item No	CH
	Revision	Index RS	Doc No	1st Language ^
				2nd Language a^
© Siemens AG 2018	Project No	E	Ref No	E
			Sheet	F of F

Main terminal diagram

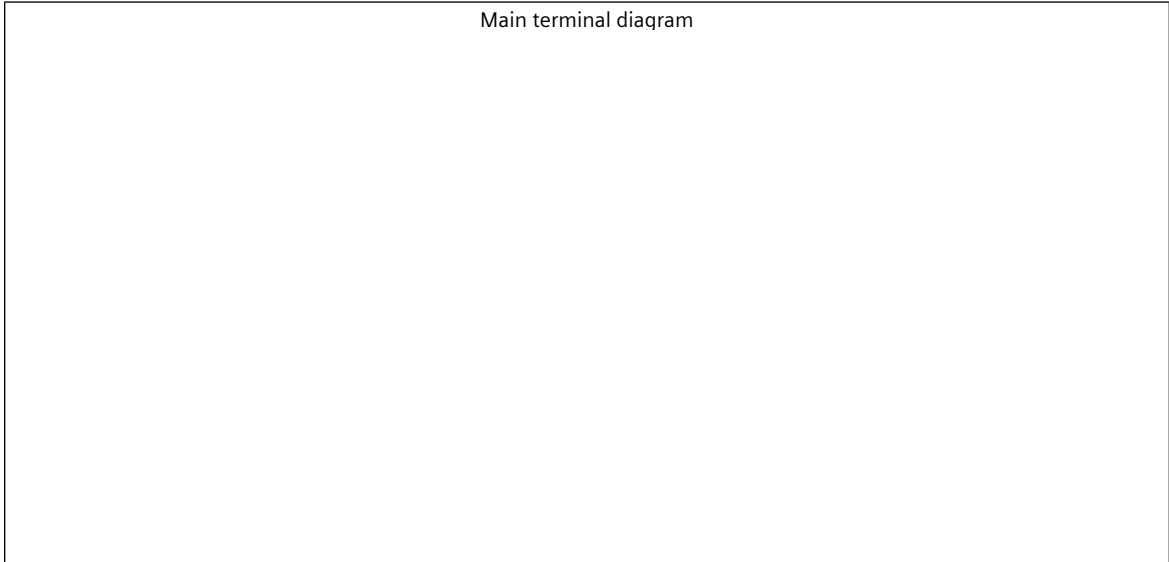

Motor protection

THERMOSTATS

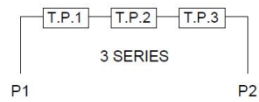

responsible dep. DI MC LVM	technical reference	created by	approved by	Project		
	document type Wiring Diagram		document status free		customer	
	title 1MB2121-4CD11-6AG3		document number			
© Siemens AG 2019			rev. 01	creation date 12/03/2019	language en	Page 1/1

SIEMENS INDUSTRY, INC.

HP 75 VOLTS <600 RPM 900 TYPE XP100
HZ 60 PHASE 3 FRAME 444T NEMA B

TORQUE & CURRENT VS. SPEED

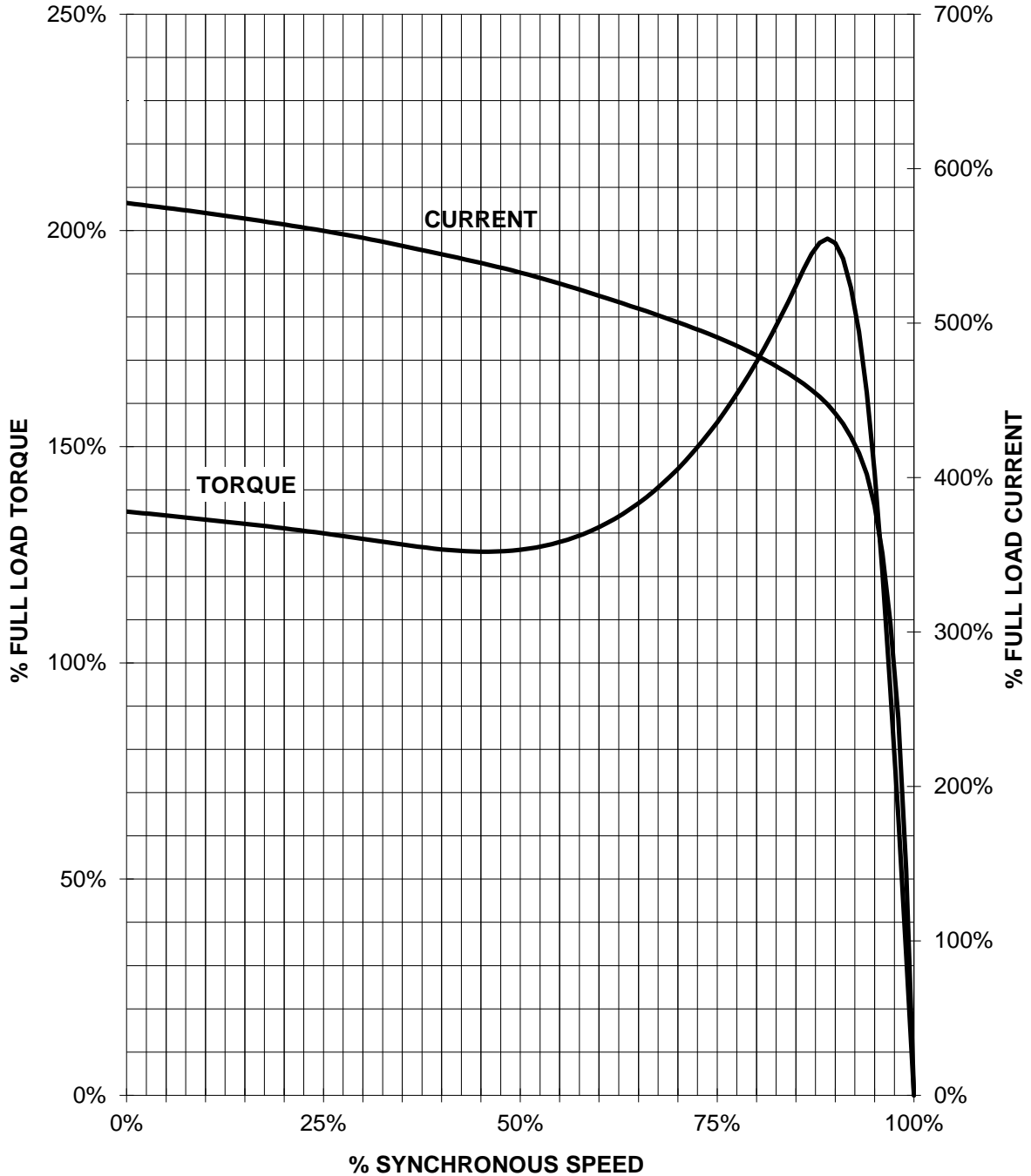

CUSTOMER: _____ ORDER#: _____