

Data sheet for three-phase Squirrel-Cage-Motors SIMOTICS

Motor type: FS: 447T - 8p - 125 hp -

Client order no.	Item-No.	Offer no.
Order no.	Consignment no.	Project

Remarks

Electrical data Class I, Div 1 Gr. C&D; Class II, Div1, Gr. F&G

U [V]	Δ/Y	f [Hz]	P [HP]	P [kW]	n [rpm]	I Load [Amps]					LRC	Nom. Eff Load [%]			Pwr. Factor Load [%]			Torque [lb-ft]	T _A /T _N LRT [%]	T _k /T _N BDT [%]
						4/4	3/4	1/2	0	4/4		3/4	2/4	4/4	3/4	2/4				
460		60	125.00	-/-	885	152.00	117.30	88.40	54.00	908.0	94.1	94.7	94.6	82.0	79.0	70.0	742.0	130	200	

Frame Type: 447T	Type of constr.: (A) Foot mounted - End shield	Ins. Cl.:Insulation class F	Motor Prot.:(G) Thermostats, Klixon type, normally closed	NEMA Des.: B	S.F.: 1.15
Mtr. WT:2,029		Temp. Rise Cl.: B	Amb. Temp.: + to -20 °C @1000 m	kVA: G	IP IP65

Mechanical data

Sound level (SPL / SWL) at 60 Hz	64.0 dB(A) / 75.0 dB(A)	Thickener	Polyurea
Octave Band Center Frequencies Hertz	250 500 1000 2000 4000 8000 Hz	Safe Stall Time Hot	20 s
SPL@3	dB(A)	Safe Stall Time Cold	30 s
Moment of inertia	64.5 Lb-ft ²	Frame material	cast iron
Ext Load Inertia Capability:	2920.0 Lb ft ²	Color, paint shade	
Bearings		Coating (paint finish)	
Bearing DE NDE	NU 320 6316 Z C3 S0	Ventilation Type	
Bearing_Type	Roller Bearing Ball Bearing	Method of cooling	TEFC
AFBMA:	100RU03M0 80BC03JP30	Direction of rotation	Bidirectional
Grease		Fan Material	Polypropylen ESD
Capacity	14.5 oz 7.5 oz	VFD	CT: n/a VT: 20:1
Grease Type:	Exxon Mobile EM	Space heaters	without
		Brake:	-/-

Terminal box

Lead Wire Connection	6 LEAD - DELTA	Terminal box position	(3) Mounting - F-1
Voltage	L1 L1 L1 Connected together	Material of terminal box	
----	----	Cable entry	-/-
----	T1 T2 T3		

Notes:
 I_r/I_N = locked rotor current / current nominal
 M_r/M_N = locked rotor torque / torque nominal
 M_b/M_N = break down torque / nominal torque
 3) Value is valid only for DOL operation with motor design IC411
 2) at rated power / at full load

responsible dep. DI MC LVM	technical reference	created by DT Configurator	approved by	<i>Technical data are subject to change! There may be discrepancies between software and hardware versions</i>			
	document type datasheet	document status released	customer		document number		
	title 1MB2121-4CD31-2AG3	rev. 01	creation date 2022-04-09 02:03	language en	Page 1/1		
© Siemens AG 2022							

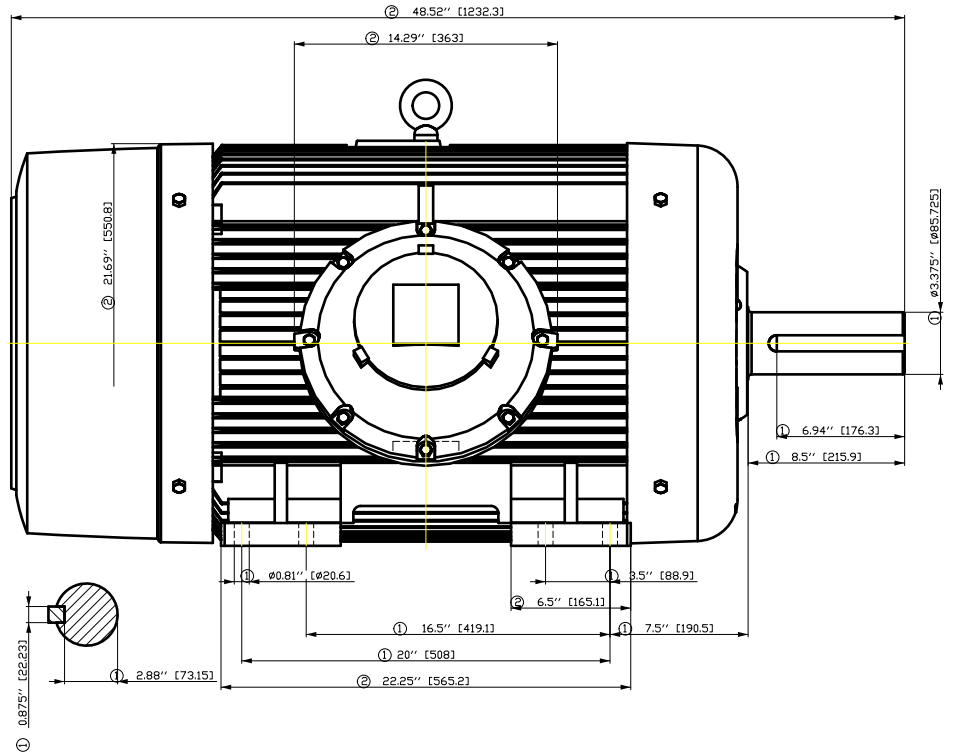
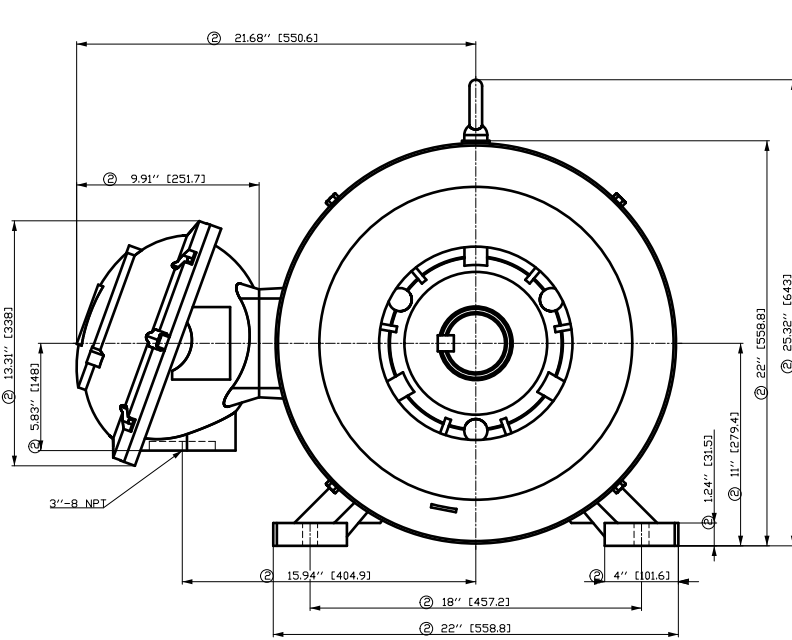

- ① Tolerances according to NEMA std.
- ② All these dimensions corresponding to assemblies and castings shall have a tolerance as per DIN standard 1686-GTB 19.
- ③ Not according to NEMA std.

Tolerance	Surface	Material	Weight	Scale
FT ÖGFCFÈ ÖÖHFÈÖÖH È	Author Creator Approval Department Change Order	ÖS T æ : ^æ@` } *	È	{ {
SIEMENS	Doc. State	I ÈÈÈÈ	Item No	Paper Size
	Revision	Index RS	Doc No	1st Language 2nd Language
© Siemens AG 2018	Project No	È	Ref No	È
			Doc Type	Sheet F of F

Main terminal diagram

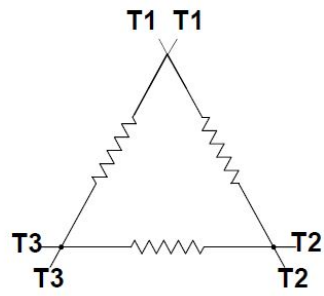

6 LEAD DELTA			
LINES			CONN.
L1	L2	L3	
T1	T2	T3	Δ

Motor protection

THERMOSTATS

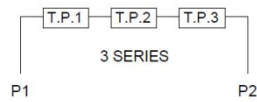

responsible dep. DI MC LVM	technical reference	created by	approved by	Project	
	document type Wiring Diagram		document status free		customer
	title 1MB2121-4CD31-2AG3		document number		
© Siemens AG 2019		rev. 01	creation date 12/03/2019	language en	Page 1/1

SIEMENS INDUSTRY, INC

HP 125 VOLTS <600 RPM 900 TYPE XP100
HZ 60 PHASE 3 FRAME 447T NEMA B

TORQUE & CURRENT VS. SPEED

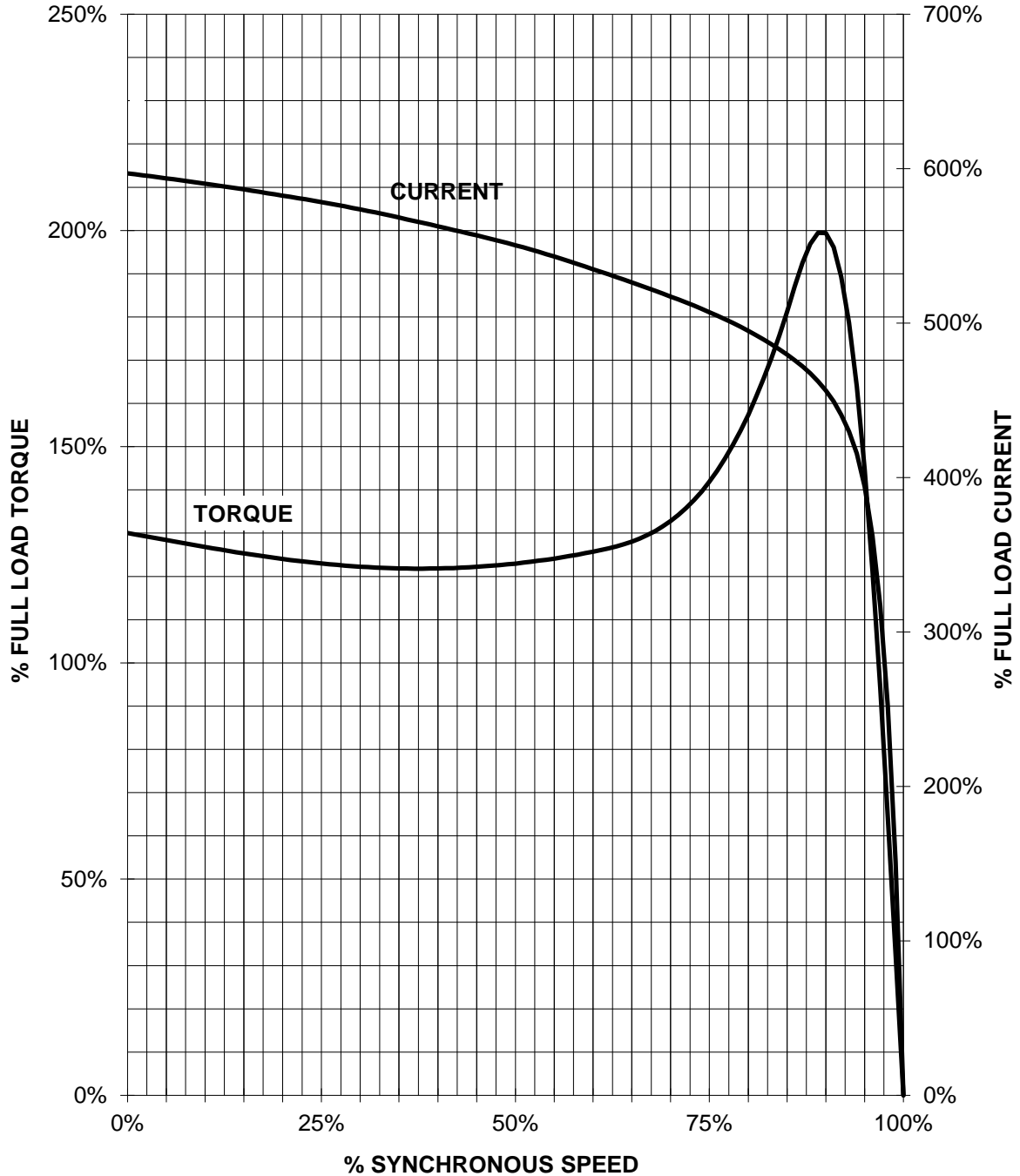

CUSTOMER: _____ ORDER#: _____