

Data sheet for three-phase Squirrel-Cage-Motors SIMOTICS

Motor type: FS: 182T - 2p - 3 hp -

Client order no.	Item-No.	Offer no.
Order no.	Consignment no.	Project

Remarks

Electrical data **Class I Division 1 Groups D**

U [V]	Δ/Y	f [Hz]	P [HP]	P [kW]	n [rpm]	I Load [Amps]					LRC	Nom. Eff Load [%]			Pwr. Factor Load [%]			Torque [lb-ft]	T _A /T _N LRT [%]	T _k /T _N BDT [%]
						4/4	3/4	1/2	0	4/4		3/4	2/4	4/4	3/4	2/4				
460		60	3.00	-/-	3,520	3.80	3.10	2.40	1.70	30.0	86.5	86.3	84.2	85.5	79.8	69.5	4.4	186	386	
230		60	3.00	-/-	3,520	7.60					86.5	86.3	84.2	85.5	79.8	69.5	4.4	186	386	

Frame Type: 182T	Type of constr.: (A) Foot mounted - End shield	Ins. Cl.:Insulation class F	Motor Prot.:(A) No winding protection	NEMA Des.: B	S.F.: 1.15
Mtr. WT:110		Temp. Rise Cl.: B	Amb. Temp.: + to -20 °C @1000 m	kVA: J	IP IP65

Mechanical data

Sound level (SPL / SWL) at 60 Hz	69.0 dB(A) / 81.0 dB(A)	Thickener	Polyurea
Octave Band Center Frequencies Hertz	250 500 1000 2000 4000 8000 Hz	Safe Stall Time Hot	20 s
SPL@3	dB(A)	Safe Stall Time Cold	30 s
Moment of inertia	0.1 Lb-ft ²	Frame material	cast iron
Ext Load Inertia Capability:	4.0 Lb ft ²	Color, paint shade	
Bearings		Coating (paint finish)	
Bearing DE NDE	6206 Z C3 S0 6206 Z C3 S0	Ventilation Type	
Bearing_Type	Ball Bearing Ball Bearing	Method of cooling	TEFC
AFBMA:	30BC02JP30 30BC02JP30	Direction of rotation	Bidirectional
Grease		Fan Material	Polypropylen ESD
Capacity	0.2 oz 0.2 oz	VFD	CT: 4:1 VT: 20:1
Grease Type:	Exxon Mobile EM	Space heaters	without
		Brake:	-/-

Terminal box

Lead Wire Connection	9 LEAD - WYE	Terminal box position	(3) Mounting - F-1
Voltage	L1 L1 L1 Connected together	Material of terminal box	
LOW	T1 T7 T2 T8 T3 T9 T4 T5 T6	Cable entry	-/-
HIGH	T1 T2 T3 T4 T7-T5 T8-T6 T9		

Notes:
 I_r/I_N = locked rotor current / current nominal
 M_r/M_N = locked rotor torque / torque nominal
 M_d/M_N = break down torque / nominal torque
 3) Value is valid only for DOL operation with motor design IC411
 2) at rated power / at full load

responsible dep. DI MC LVM	technical reference	created by DT Configurator	approved by	<i>Technical data are subject to change! There may be discrepancies between software and hardware versions.</i>
-------------------------------	---------------------	-------------------------------	-------------	---

	document type datasheet	document status released	customer	
	title 1MB2221-1CA11-4AA3	document number		
© Siemens AG 2022	rev. 01	creation date 2022-04-08 17:50	language en	Page 1/1

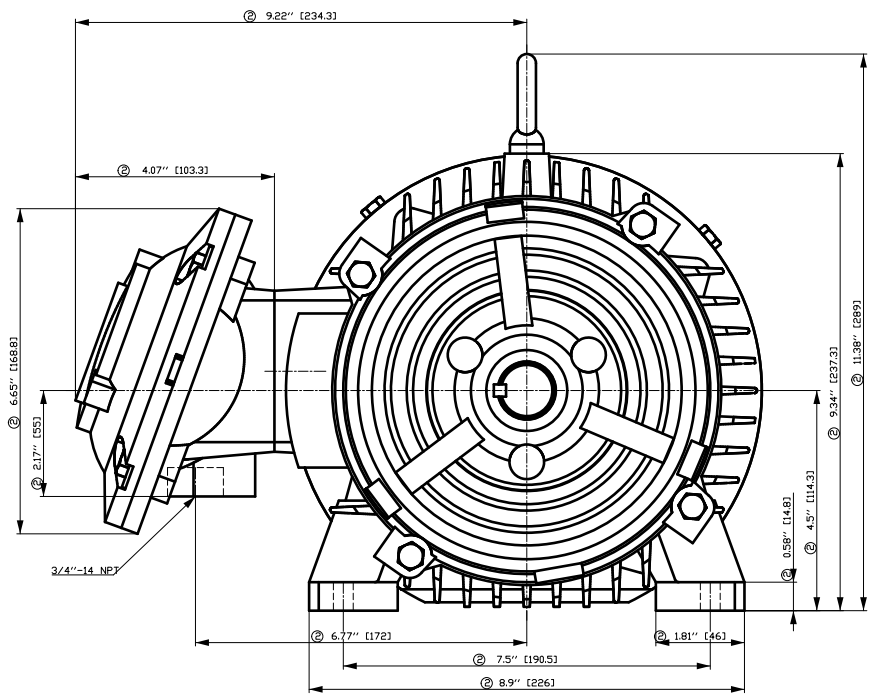

- ① Tolerances according to NEMA std.
- ② All these dimensions corresponding to assemblies and castings shall have a tolerance as per DIN standard 1686-GTB 19.
- ③ Not according to NEMA std.

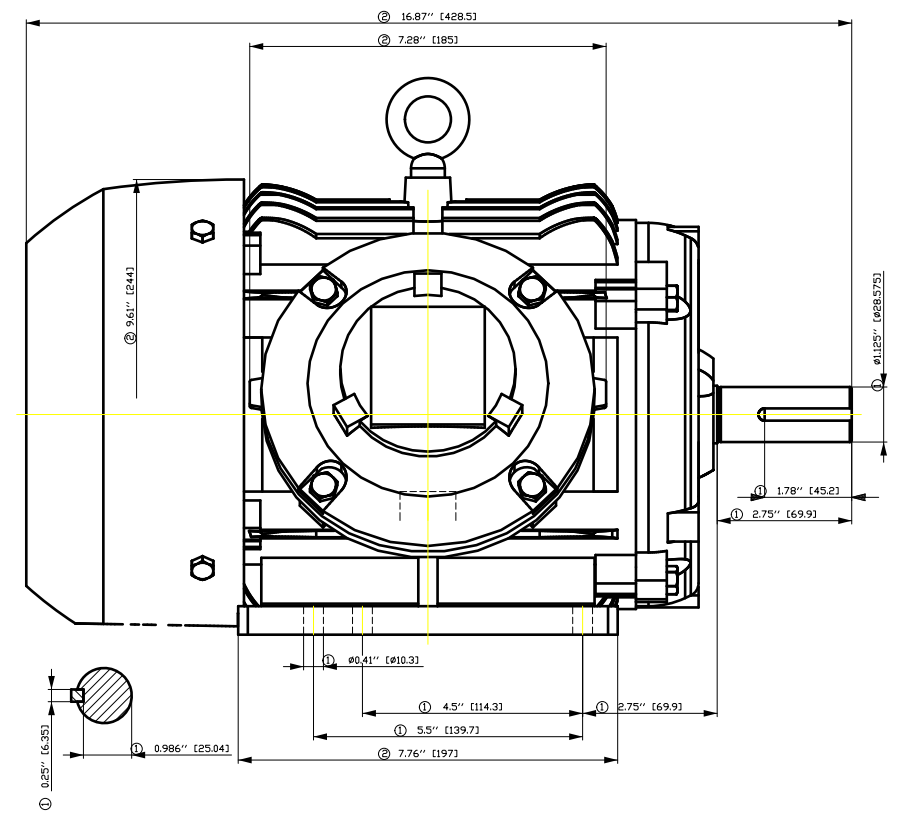

Tolerance	Surface	Material	Weight	Scale
FT ÖGGGF-ÖÖFFÖ ÖÖH	Author	Öö ^)•ö)öööö ö*	É	{ {
É	Creator	ÖVS		
	Approval	T ä : ^ö@ } *		
	Department			
	Change Order	MLFB		Doc Type
SIEMENS	Doc. State	I ÖGG	Item No	Paper Size
© Siemens AG	Revision	Index	Doc No	1st Language ^)
2018	Project No	É	Ref No	2nd Language ä^
				Sheet F of F

Main terminal diagram

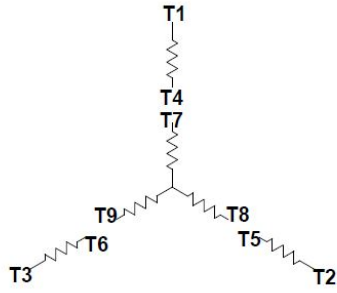

9 LEAD WYE						
Volts	LINES			CONNECTED TOGETHER	CONN.	
	L1	L2	L3			
LOW	T1 T7	T2 T6	T3 T9	T4 T5 T6	YY	
HIGH	T1	T2	T3	T4 T7-T5 T8-T6 T9	Y	

responsible dep. DI MC LVM	technical reference	created by	approved by	Project
SIEMENS	document type Wiring Diagram	document status free		customer
	title 1MB2221-1CA11-4AA3	document number		
© Siemens AG 2019	rev. 01	creation date 12/03/2019	language en	Page 1/1

SIEMENS INDUSTRY, INC.

HP 3 VOLTS <600 RPM 3600 TYPE XP100 1D1
HZ 60 PHASE 3 FRAME 182T NEMA B

TORQUE & CURRENT VS. SPEED

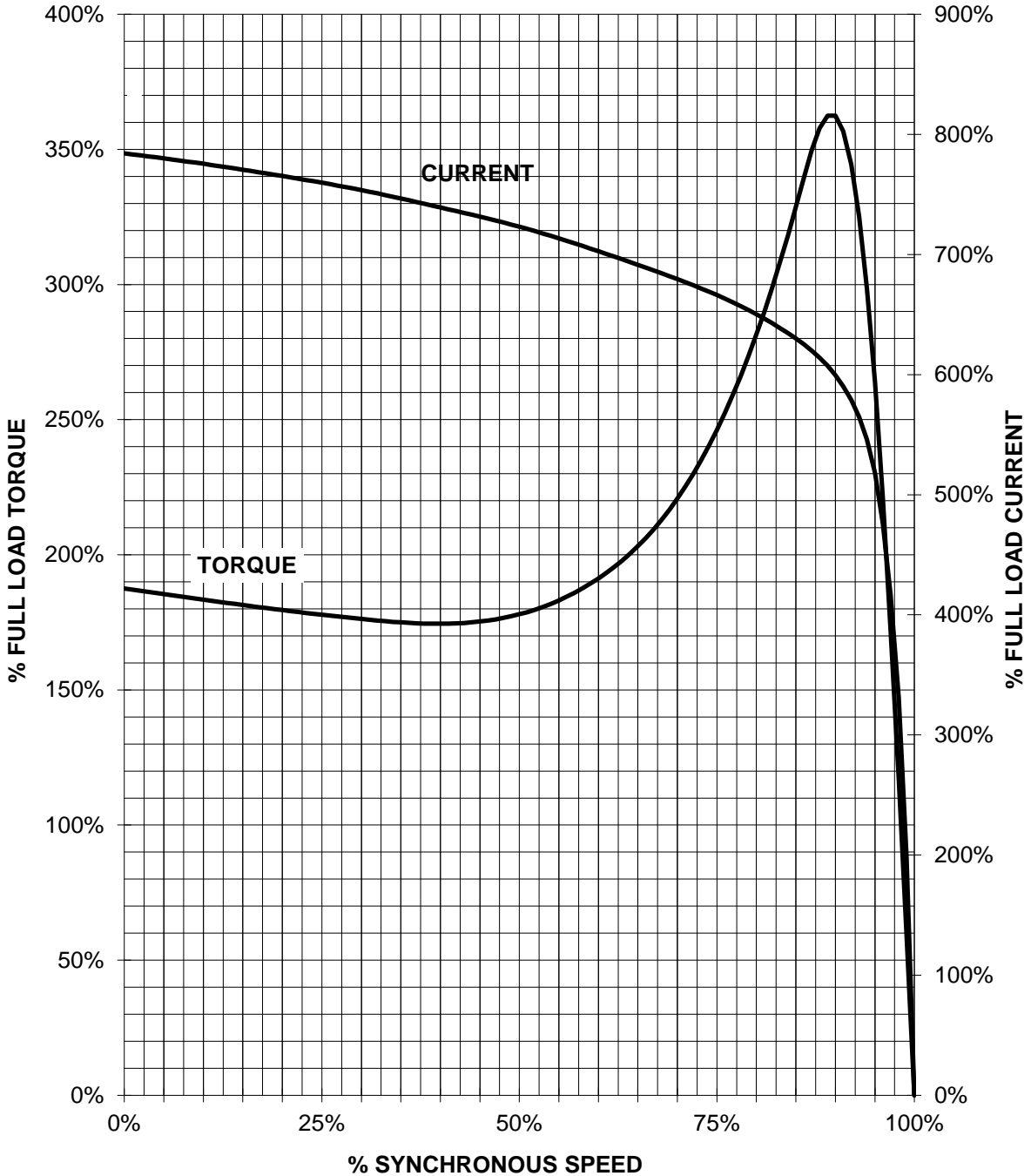

CUSTOMER: _____ ORDER#: _____

3 HP 3600 RPM 182T FRAME 460 VOLTS 3 PHASE NEMA DESIGN B

SIEMENS INDUSTRY, INC.
PERFORMANCE CURVE
XP100 1D1

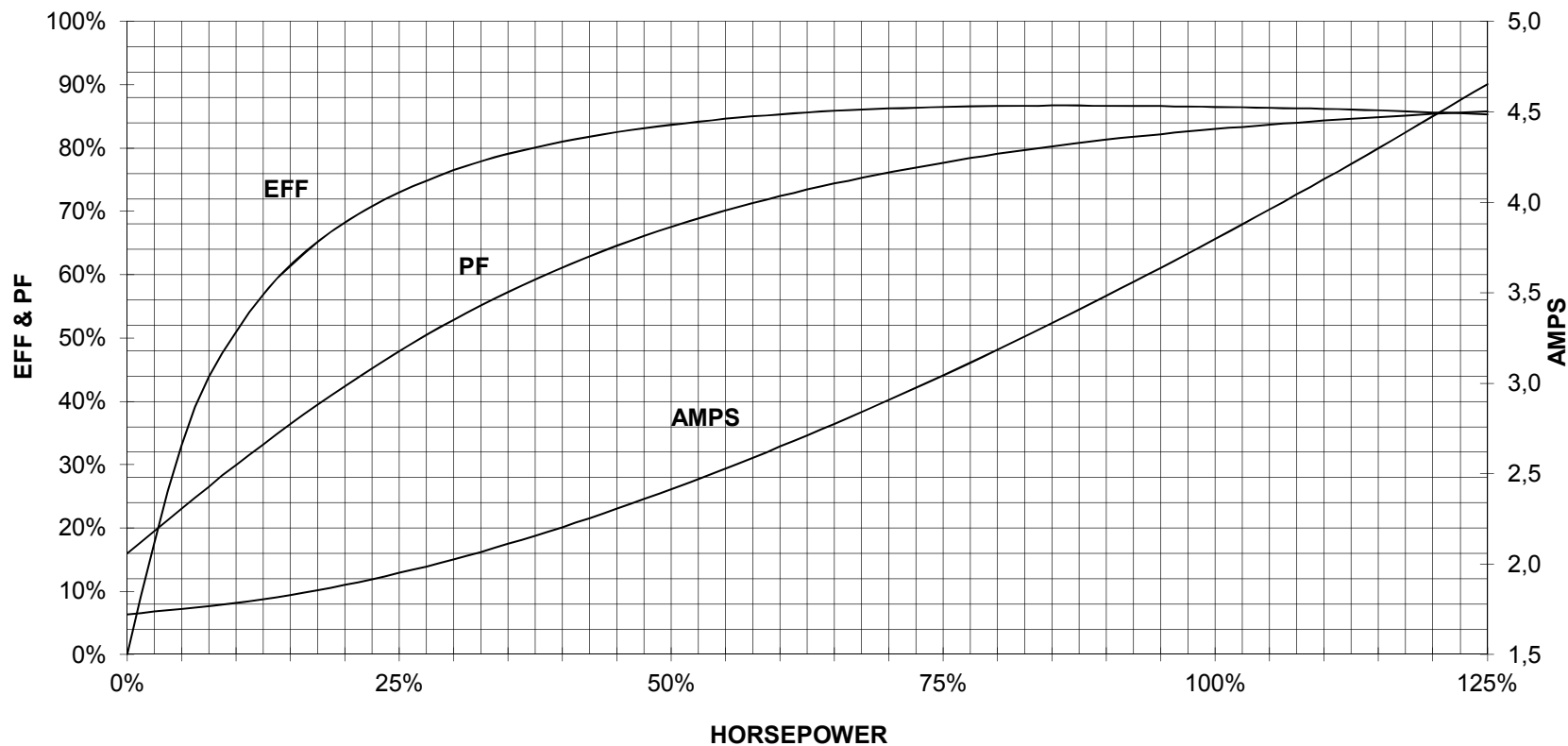

CUSTOMER _____ ORDER # _____ PO # _____

PERFORMANCE BASED ON DESIGN CALCULATIONS. SUBJECT TO CHANGE WITHOUT NOTICE.

REV. 1