

Data sheet for three-phase Squirrel-Cage-Motors SIMOTICS

Motor type: FS: 215TC - 4p - 10 hp -

Client order no.	Item-No.	Offer no.
Order no.	Consignment no.	Project

Remarks

Electrical data **Class I Division 1 Groups D**

U [V]	Δ/Y	f [Hz]	P [HP]	P [kW]	n [rpm]	I Load [Amps]					Nom. Eff Load [%]			Pwr. Factor Load [%]			Torque [lb-ft]	T _A /T _N LRT [%]	T _k /T _N BDT [%]
						4/4	3/4	1/2	0	LRC	4/4	3/4	2/4	4/4	3/4	2/4			
460		60	10.00	-/-	1,755	12.50	10.00	8.00	6.10	81.0	91.7	92.2	91.7	81.7	76.2	63.8	30.0	270	410
230		60	10.00	-/-	1,755	25.00					91.7	92.2	91.7	81.7	76.2	63.8	30.0	270	410

Frame Type: 215TC	Type of constr.: (G) Round body - C-Face	Ins. Cl.:Insulation class F	Motor Prot.:(A) No winding protection	NEMA Des.: B	S.F.: 1.15
Mtr. WT:200		Temp. Rise Cl.: B	Amb. Temp.: + to -20 °C @1000 m	kVA: H	IP IP65

Mechanical data

Sound level (SPL / SWL) at 60 Hz	57.0 dB(A) / 69.0 dB(A)	Thickener	Polyurea
Octave Band Center Frequencies Hertz	250 500 1000 2000 4000 8000 Hz	Safe Stall Time Hot	20 s
SPL@3		Safe Stall Time Cold	36 s
Moment of inertia	0.9 Lb-ft ²	Frame material	cast iron
Ext Load Inertia Capability:	51.0 Lb ft ²	Color, paint shade	
Bearings		Coating (paint finish)	
Bearing DE NDE	6208 Z C3 S0 6208 Z C3 S0	Ventilation Type	
Bearing_Type	Ball Bearing Ball Bearing	Method of cooling	TEFC
AFBMA:	40BC02JP30 40BC02JP30	Direction of rotation	Bidirectional
Grease		Fan Material	Polypropylen ESD
Capacity	0.3 oz 0.3 oz	VFD	CT: 4:1 VT: 20:1
Grease Type:	Exxon Mobile EM	Space heaters	without
		Brake:	-/-

Terminal box

Lead Wire Connection	9 LEAD - WYE	Terminal box position	(3) Mounting - F-1
Voltage	L1 L1 L1 Connected together	Material of terminal box	
LOW	T1 T7 T2 T8 T3 T9 T4 T5 T6	Cable entry	-/-
HIGH	T1 T2 T3 T4 T7-T5 T8-T6 T9		

Notes:
 I_r/I_N = locked rotor current / current nominal
 M_r/M_N = locked rotor torque / torque nominal
 M_d/M_N = break down torque / nominal torque
 3) Value is valid only for DOL operation with motor design IC411
 2) at rated power / at full load

responsible dep. DI MC LVM	technical reference	created by DT Configurator	approved by	<i>Technical data are subject to change! There may be discrepancies between software and hardware versions</i>
-------------------------------	---------------------	-------------------------------	-------------	--

	document type datasheet	document status released	customer	
	title 1MB2221-2AB21-6GA3	document number	rev.	creation date
© Siemens AG 2022		01	2022-04-08 19:01	language Page en 1/1

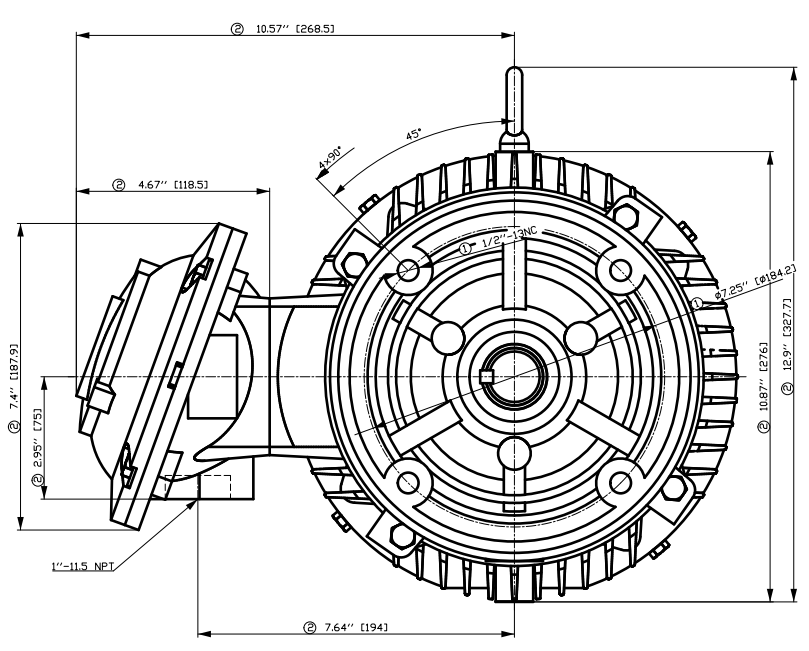

- ① Tolerances according to NEMA std.
- ② All these dimensions corresponding to assemblies and castings shall have a tolerance as per DIN standard 1686-GTB 19.
- ③ Not according to NEMA std.

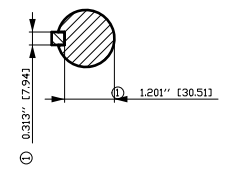
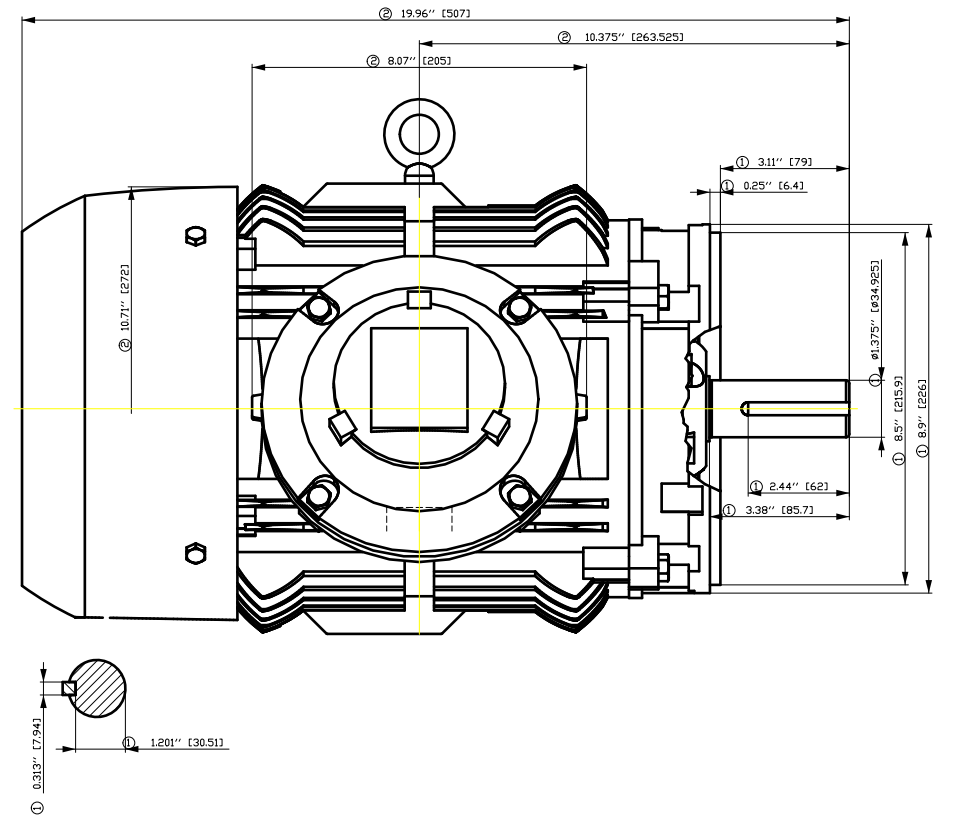

Tolerance	Surface	Material	Weight	Scale
FT ÖGGE FÖR ÖCH	Author	ÖB \) • 4) 2/1/2 3 *	È	{ {
È	Creator	ÖVS		
	Approval	T æ : ^ 2 @ } *		
	Department			
	Change Order	MFB		Doc Type
	Doc. State	I Ø ÖG		Paper Size
SIEMENS	Revision	Index	Item No	1st Language
© Siemens AG	2018	RS	Doc No	2nd Language
	Project No	È	Ref No	È
				Sheet F of F

刀线管
 用转为
 文全
 金图
 版
 印
 行
 01
 02
 03
 04
 05
 06
 07
 08
 09
 10
 11
 12
 13
 14
 15
 16
 17
 18
 19
 20
 21
 22
 23
 24
 25
 26
 27
 28
 29
 30
 31
 32
 33
 34
 35
 36
 37
 38
 39
 40
 41
 42
 43
 44
 45
 46
 47
 48
 49
 50
 51
 52
 53
 54
 55
 56
 57
 58
 59
 60
 61
 62
 63
 64
 65
 66
 67
 68
 69
 70
 71
 72
 73
 74
 75
 76
 77
 78
 79
 80
 81
 82
 83
 84
 85
 86
 87
 88
 89
 90
 91
 92
 93
 94
 95
 96
 97
 98
 99
 100

Main terminal diagram

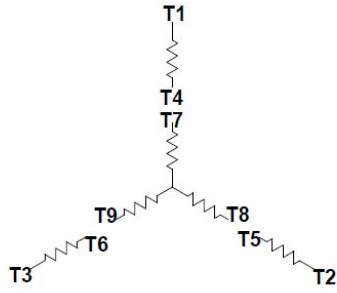

9 LEAD WYE						
Volts	LINES			CONNECTED TOGETHER	CONN.	
	L1	L2	L3			
LOW	T1 T7	T2 T6	T3 T9	T4 T5 T6	YY	
HIGH	T1	T2	T3	T4 T7-T5 T8-T6 T9	Y	

responsible dep. DI MC LVM	technical reference	created by	approved by	Project
SIEMENS	document type Wiring Diagram	document status free		customer
	title 1MB2221-2AB21-6GA3	document number		
© Siemens AG 2019	rev. 01	creation date 12/03/2019	language en	Page 1/1

SIEMENS INDUSTRY, INC.

HP 10 VOLTS <600 RPM 1800 TYPE XP100 1D1
HZ 60 PHASE 3 FRAME 215T NEMA B

TORQUE & CURRENT VS. SPEED

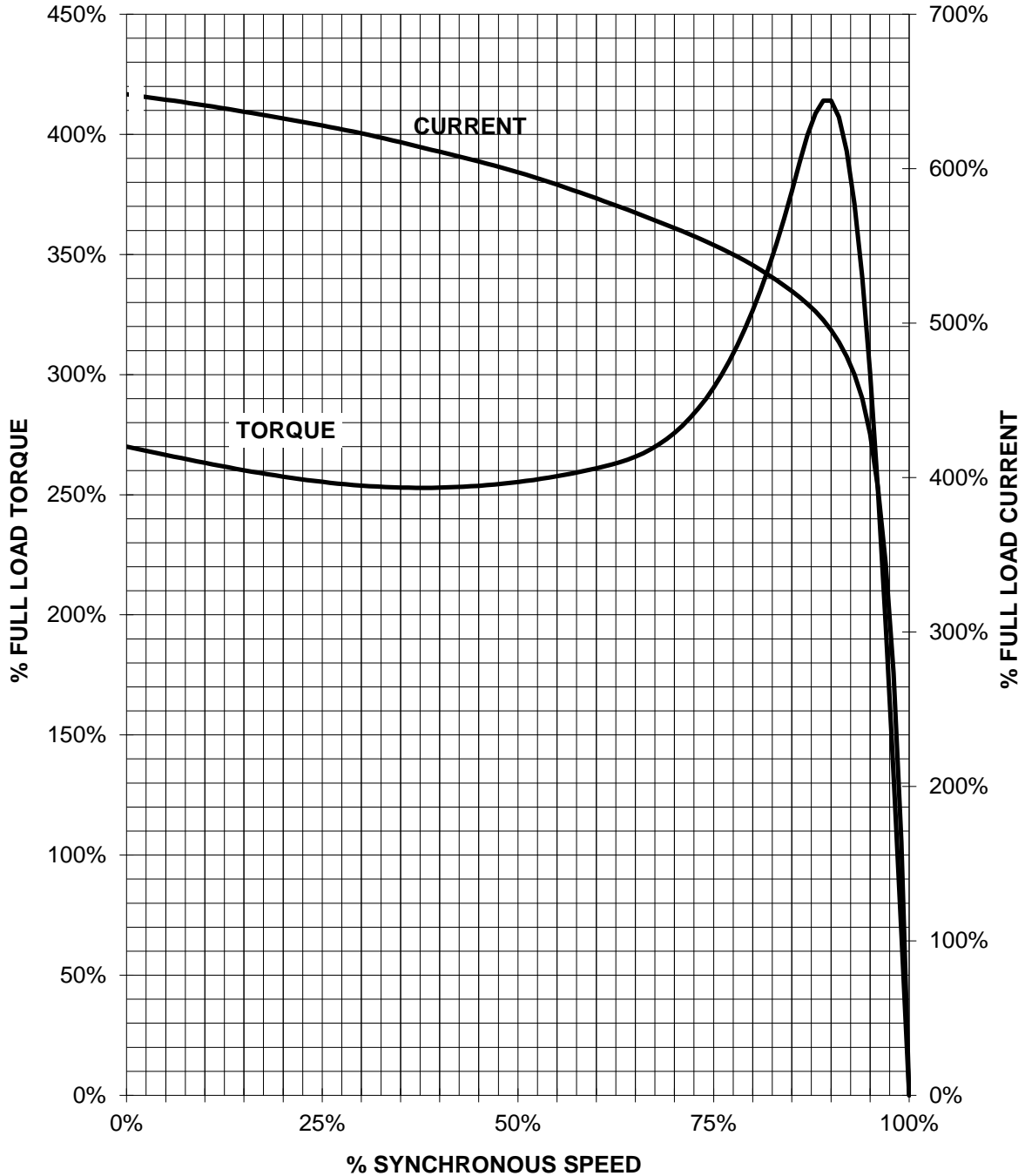

CUSTOMER: _____ ORDER#: _____