

Data sheet for three-phase Squirrel-Cage-Motors SIMOTICS

Motor type: FS: 254T - 4p - 15 hp -

| | | |
|------------------|-----------------|-----------|
| Client order no. | Item-No. | Offer no. |
| Order no. | Consignment no. | Project |

Remarks

Electrical data Class I Division 1 Groups D

| U [V] | Δ/Y | f [Hz] | P [HP] | P [kW] | n [rpm] | I Load [Amps] | | | | | LRC | Nom. Eff Load [%] | | | Pwr. Factor Load [%] | | | Torque [lb-ft] | T _A /T _N LRT [%] | T _k /T _N BDT [%] |
|-------|------------|--------|--------|--------|---------|---------------|-------|------|------|------|------|-------------------|------|------|----------------------|------|------|----------------|--|--|
| | | | | | | 4/4 | 3/4 | 1/2 | 0 | 4/4 | | 3/4 | 2/4 | 4/4 | 3/4 | 2/4 | | | | |
| 575 | | 60 | 15.00 | -/- | 1,770 | 15.20 | 12.20 | 9.40 | 6.80 | 92.8 | 92.4 | 92.8 | 92.3 | 80.0 | 74.7 | 64.5 | 44.0 | 184 | 234 | |

| | | | | | |
|------------------|--|-----------------------------|---------------------------------------|--------------|------------|
| Frame Type: 254T | Type of constr.: (A) Foot mounted - End shield | Ins. Cl.:Insulation class F | Motor Prot.:(A) No winding protection | NEMA Des.: B | S.F.: 1.15 |
| Mtr. WT:315 | | Temp. Rise Cl.: B | Amb. Temp.: + to -20 °C @1000 m | kVA: G | IP IP65 |

Mechanical data

| | | | |
|--------------------------------------|--------------------------------|-------------------------|------------------|
| Sound level (SPL / SWL) at 60 Hz | 61.0 dB(A) / 73.0 dB(A) | Thickener | Polyurea |
| Octave Band Center Frequencies Hertz | 250 500 1000 2000 4000 8000 Hz | Safe Stall Time Hot | 21 s |
| SPL@3 | | Safe Stall Time Cold | 33 s |
| Moment of inertia | 1.7 Lb-ft ² | Frame material | cast iron |
| Ext Load Inertia Capability: | 75.0 Lb ft ² | Color, paint shade | |
| Bearings | | Coating (paint finish) | |
| Bearing DE NDE | 6309 Z C3 S0 6309 Z C3 S0 | Ventilation Type | |
| Bearing_Type | Ball Bearing Ball Bearing | Method of cooling | TEFC |
| AFBMA: | 45BC03JP30 45BC03JP30 | Direction of rotation | Bidirectional |
| Grease | | Fan Material | Polypropylen ESD |
| Capacity | 0.5 oz 0.5 oz | VFD | CT: 4:1 VT: 20:1 |
| Grease Type: | Exxon Mobile EM | Space heaters | without |
| | | Brake: | -/- |

Terminal box

| | | | |
|----------------------|-----------------------------|--------------------------|--------------------|
| Lead Wire Connection | 3 LEAD - WYE | Terminal box position | (3) Mounting - F-1 |
| Voltage | L1 L1 L1 Connected together | Material of terminal box | |
| --- | --- | Cable entry | -/- |
| --- | T1 T2 T3 | | |

Notes:
 I_r/I_N = locked rotor current / current nominal
 M_r/M_N = locked rotor torque / torque nominal
 M_b/M_N = break down torque / nominal torque
 3) Value is valid only for DOL operation with motor design IC411
 2) at rated power / at full load

| | | | | |
|-------------------------------|---------------------|-------------------------------|-------------|--|
| responsible dep. DI MC LVM | technical reference | created by DT Configurator | approved by | <i>Technical data are subject to change! There may be discrepancies between software and hardware versions</i> |
|-------------------------------|---------------------|-------------------------------|-------------|--|

| | | | | | |
|-------------------|-----------------------------|-----------------------------|-----------------------------------|----------------|-------------|
| | document type datasheet | document status released | customer | | |
| | title 1MB2221-2BB11-3AA3 | document number | | | |
| © Siemens AG 2022 | | rev. 01 | creation date 2022-04-08 20:23 | language en | Page 1/1 |

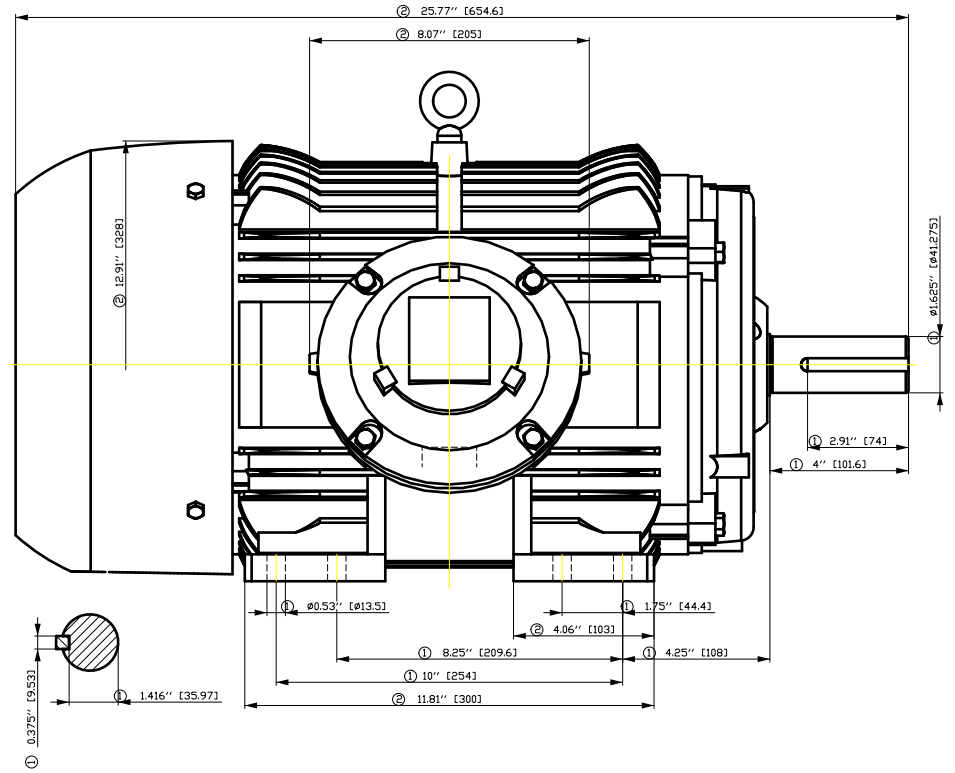
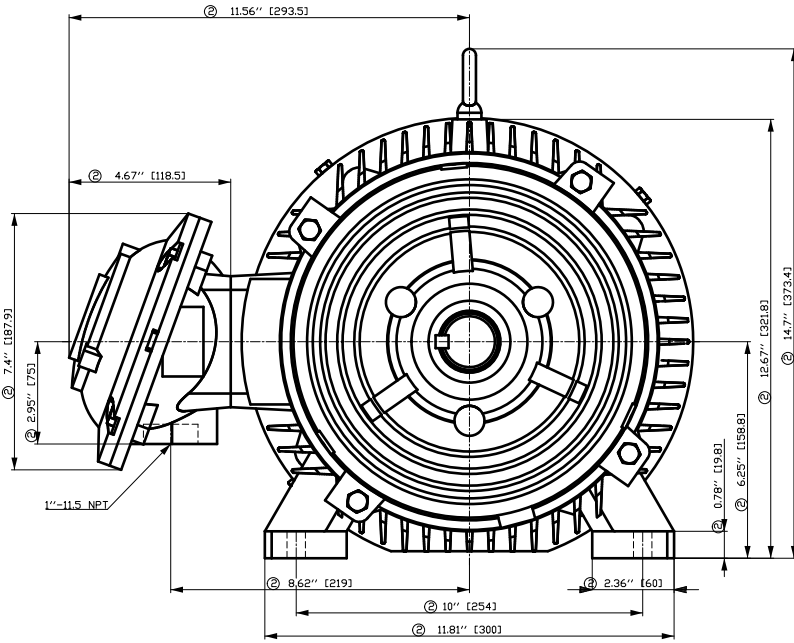

- ① Tolerances according to NEMA std.
- ② All these dimensions corresponding to assemblies and castings shall have a tolerance as per DIN standard 1686-GTB 19.
- ③ Not according to NEMA std.

| Tolerance | Surface | Material | Weight | Scale | |
|-------------------|--------------|------------------|----------|--------------|--------------|
| FT ÖGGRÉÓÓFFÉÖEH | Author | Öä ^)•ä)ä/ä/ä ä* | E | | |
| E | Creator | | | | ÖVS |
| | Approval | | | | T ä : ^ä@ }* |
| | Department | | | | |
| | Change Order | MFB | Doc Type | / | |
| | Doc. State | I ð ÖG | Item No | Paper Size | |
| | Revision | Index RS | Doc No | 1st Language | |
| | | | | 2nd Language | |
| © Siemens AG 2018 | Project No | E | Ref No | E | |
| | | | | Sheet F of F | |

Main terminal diagram

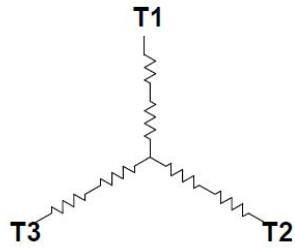

| 3 LEAD WYE | | | |
|------------|----|----|-------|
| LINES | | | CONN. |
| L1 | L2 | L3 | |
| T1 | T2 | T3 | Y |

| | | | | | | |
|--|---------------------------------|------------|-------------------------|-----------------------------|----------------|-------------|
| responsible dep. DI MC LVM | technical reference | created by | approved by | Project | | |
|  | document type Wiring Diagram | | document status free | | customer | |
| | title 1MB2221-2BB11-3AA3 | | document number | | | |
| © Siemens AG 2019 | | | rev. 01 | creation date 12/03/2019 | language en | Page 1/1 |

SIEMENS INDUSTRY, INC.

HP 15 VOLTS <600 RPM 1800 TYPE XP100 1D1
HZ 60 PHASE 3 FRAME 254T NEMA B

TORQUE & CURRENT VS. SPEED

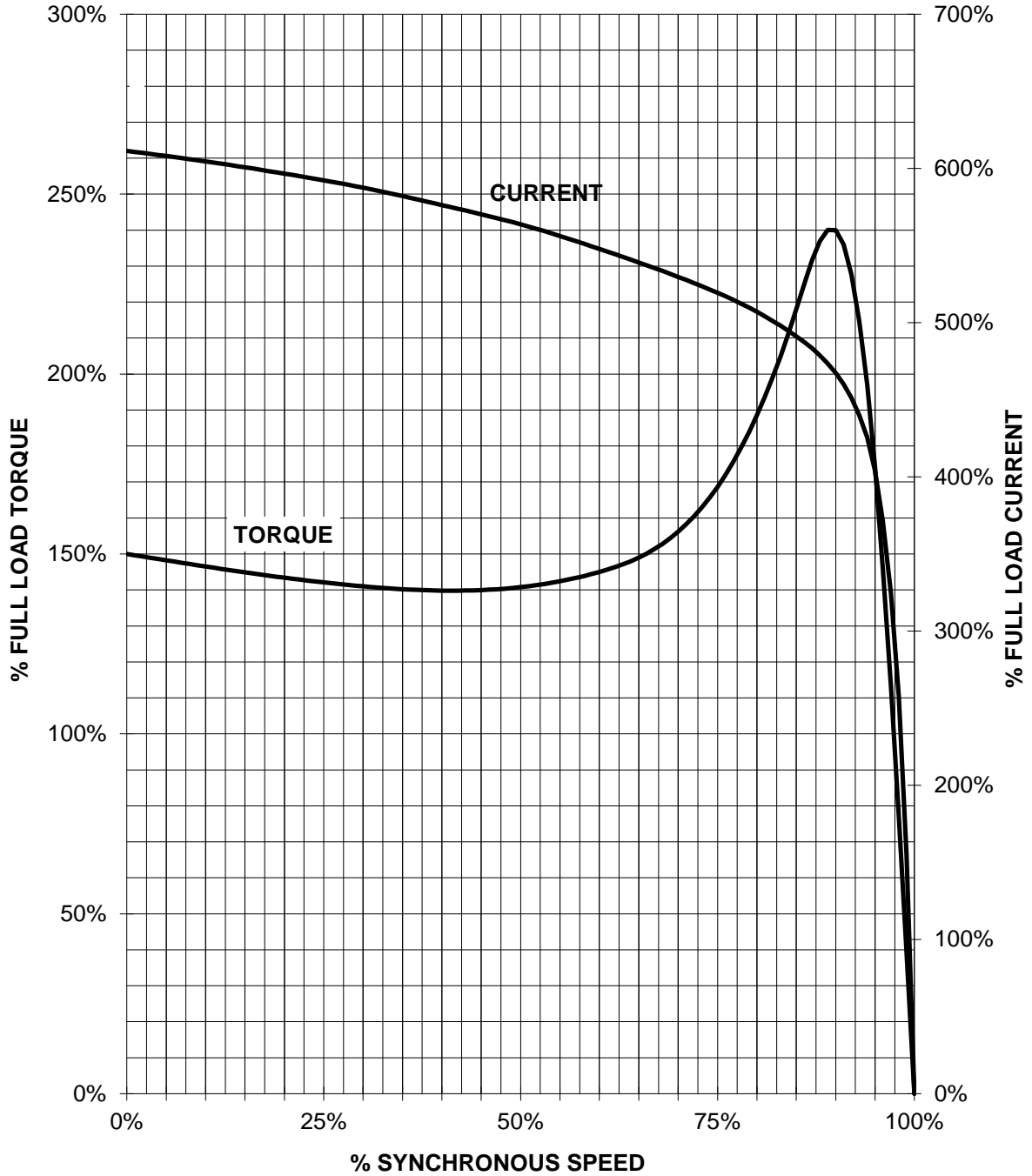

CUSTOMER: _____ ORDER#: _____

15 HP 1800 RPM 254T FRAME 575 VOLTS 3 PHASE NEMA DESIGN B

**SIEMENS INDUSTRY, INC.
PERFORMANCE CURVE
XP100 1D1**

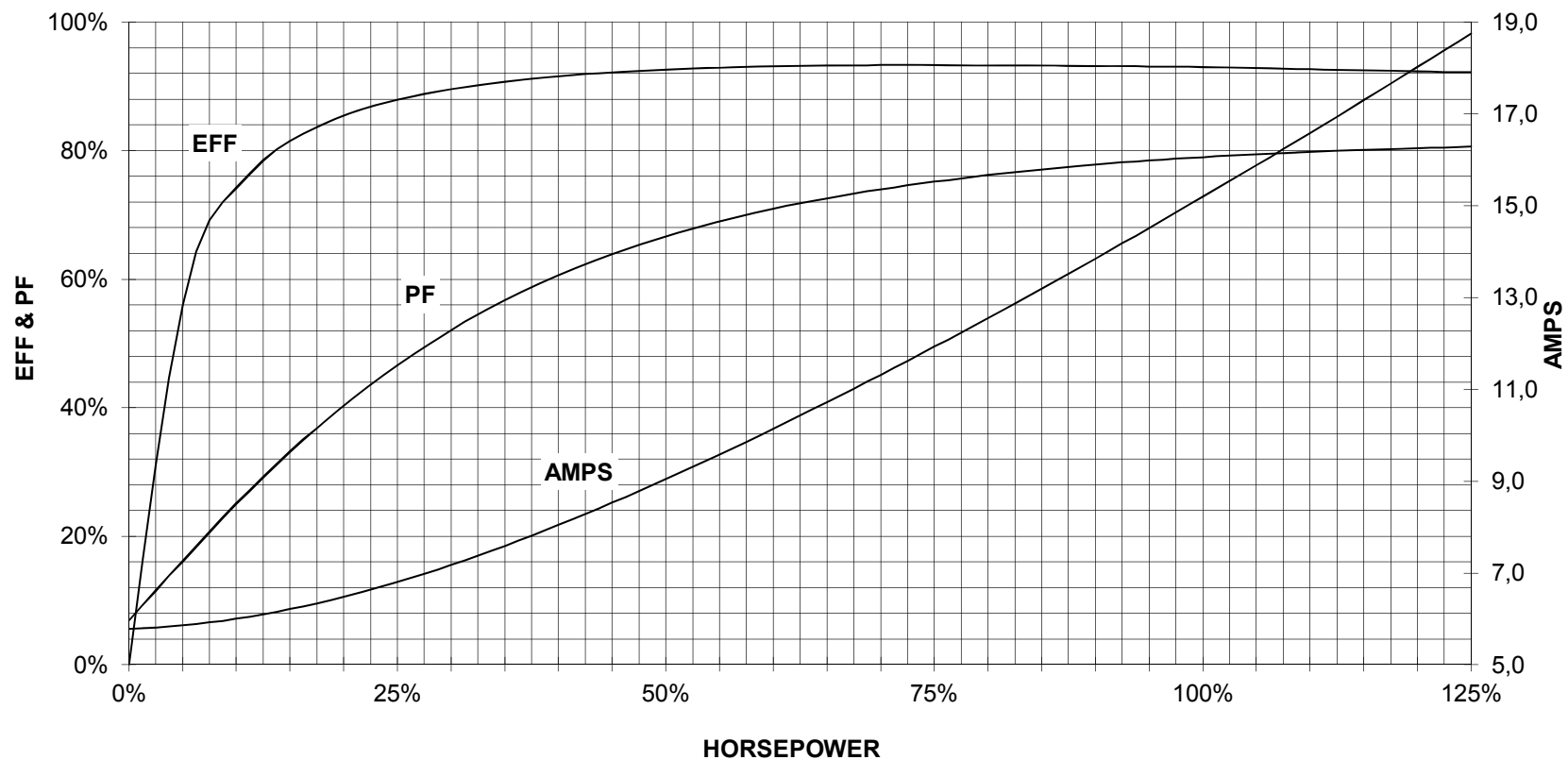

CUSTOMER _____ ORDER # _____ PO # _____

PERFORMANCE BASED ON DESIGN CALCULATIONS. SUBJECT TO CHANGE WITHOUT NOTICE.

REV. 1