

Data sheet for three-phase Squirrel-Cage-Motors SIMOTICS

Motor type: FS: 324T - 4p - 40 hp -

Client order no.	Item-No.	Offer no.
Order no.	Consignment no.	Project
Remarks		

Electrical data **Class I Division 1 Groups D**

U [V]	Δ/Y	f [Hz]	P [HP]	P [kW]	n [rpm]	I Load [Amps]					Nom. Eff Load [%]			Pwr. Factor Load [%]			Torque [lb-ft]	T _A /T _N LRT [%]	T _k /T _N BDT [%]
						4/4	3/4	1/2	0	LRC	4/4	3/4	2/4	4/4	3/4	2/4			
575		60	40.00	-/-	1,780	36.80	28.80	21.20	12.00	232.0	94.1	94.1	94.3	86.0	83.0	75.0	118.0	180	231
Frame Type: 324T		Type of constr.: (A) Foot mounted - End shield				Ins. Cl.:Insulation class F		Motor Prot.:(A) No winding protection			NEMA Des.: B		S.F.: 1.15						
Mtr. WT:653						Temp. Rise Cl.: B		Amb. Temp.: + to -20 °C @1000 m			kVA: G		IP IP65						

Mechanical data

Sound level (SPL / SWL) at 60 Hz	64.0 dB(A) / 75.0 dB(A)	Thickener	Polyurea
Octave Band Center Frequencies Hertz		Safe Stall Time Hot	22 s
250	500	1000	2000
4000	8000	Hz	
SPL@3		dB(A)	
Moment of inertia	9.4 Lb-ft ²	Safe Stall Time Cold	45 s
Ext Load Inertia Capability:	189.0 Lb ft ²	Frame material	cast iron
Bearings		Color, paint shade	
Bearing DE NDE	6312 Z C3 S0	6312 Z C3 S0	
Bearing_Type	Ball Bearing	Ball Bearing	
AFBMA:	60BC03JP30	60BC03JP30	
Grease		Coating (paint finish)	
Capacity	5.5 oz	5.5 oz	
Grease Type:	Exxon Mobile EM	Ventilation Type	
		Method of cooling	TEFC
		Direction of rotation	Bidirectional
		Fan Material	Polypropylen ESD
		VFD	CT: 4:1 VT: 20:1
		Space heaters	without
		Brake:	-/-

Terminal box

Lead Wire Connection	3 LEAD - DELTA	Terminal box position	(3) Mounting - F-1
Voltage	L1 L1 L1	Material of terminal box	
---	---	Cable entry	-/-
---	T1 T2 T3		

Notes:			
I _L /I _N = locked rotor current / current nominal	M _L /M _N = locked rotor torque / torque nominal	M _B /M _N = break down torque / nominal torque	3) Value is valid only for DOL operation with motor design IC411 2) at rated power / at full load

responsible dep. DI MC LVM	technical reference	created by DT Configurator	approved by	<i>Technical data are subject to change! There may be discrepancies between software and hardware versions</i>			
	document type datasheet	document status released	customer				
	title 1MB2221-3AB11-3AA3	document number					
© Siemens AG 2022		rev. 01	creation date 2022-04-08 21:44	language en	Page 1/1		

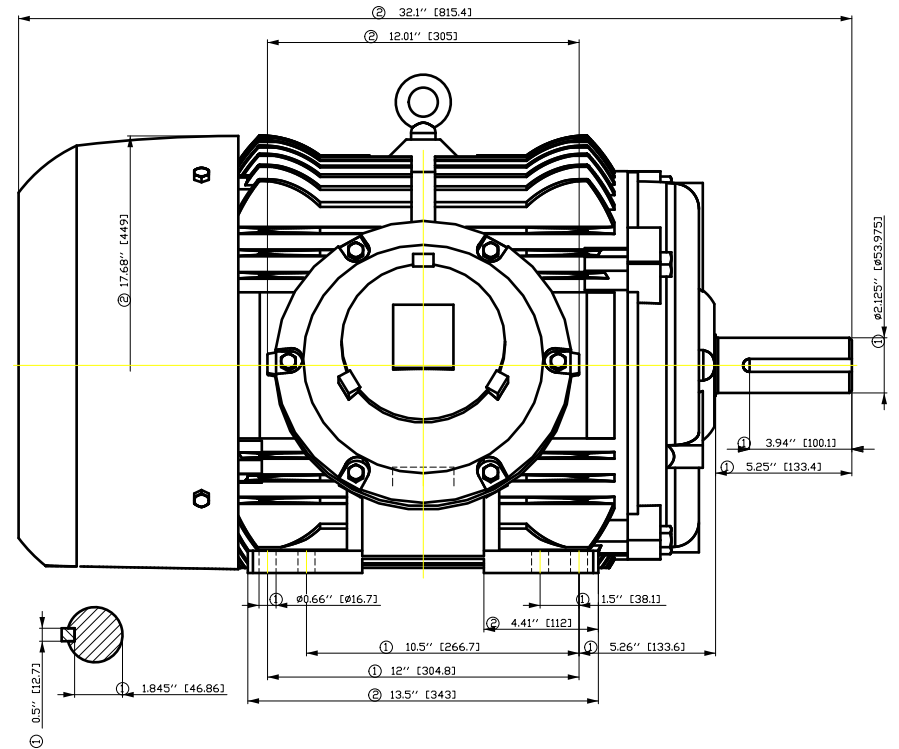
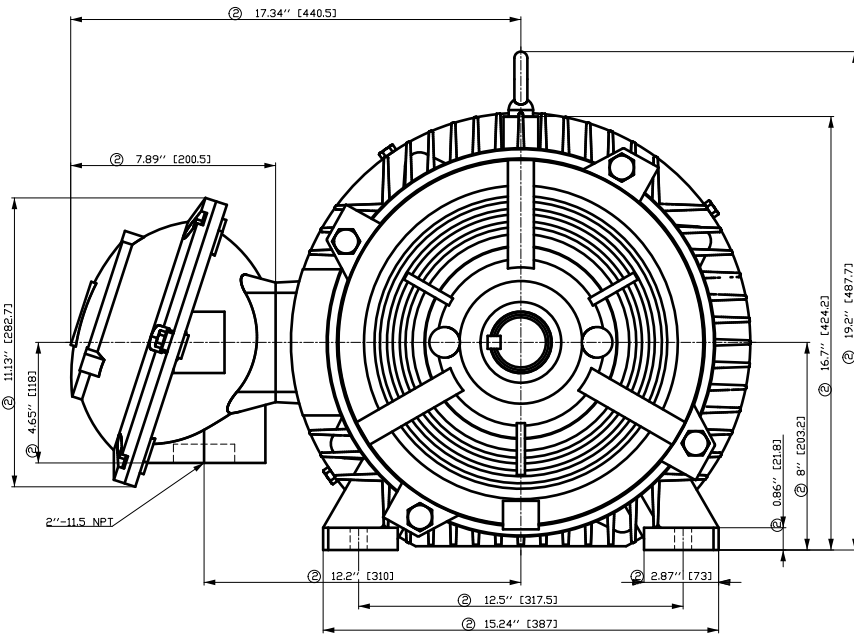

- ① Tolerances according to NEMA std.
- ② All these dimensions corresponding to assemblies and castings shall have a tolerance as per DIN standard 1686-GTB 19.
- ③ Not according to NEMA std.

Tolerance	Surface	Material	Weight	Scale
FT ÖGGEFFÖFFÖH É	Author Creator Approval Department Change Order	ÖS Tæ: ^æ@`)*	É	{ {
SIEMENS	Doc. State	I ð ÖG	Doc Type	CH
	Revision	Index RS	Paper Size	1st Language ^) 2nd Language â^
	Project No	É	Item No	Doc No
	© Siemens AG 2018	É	Ref No	É
			Sheet	F of F

Main terminal diagram

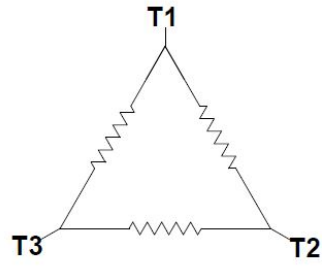

3 LEAD DELTA			
LINES			CONN.
L1	L2	L3	
T1	T2	T3	Δ

responsible dep. DI MC LVM	technical reference	created by	approved by	Project		
	document type Wiring Diagram		document status free		customer	
	title 1MB2221-3AB11-3AA3		document number			
© Siemens AG 2019			rev. 01	creation date 12/03/2019	language en	Page 1/1

SIEMENS INDUSTRY, INC.

HP 40 VOLTS <600 RPM 1800 TYPE XP100 1D1
HZ 60 PHASE 3 FRAME 324T NEMA B

TORQUE & CURRENT VS. SPEED

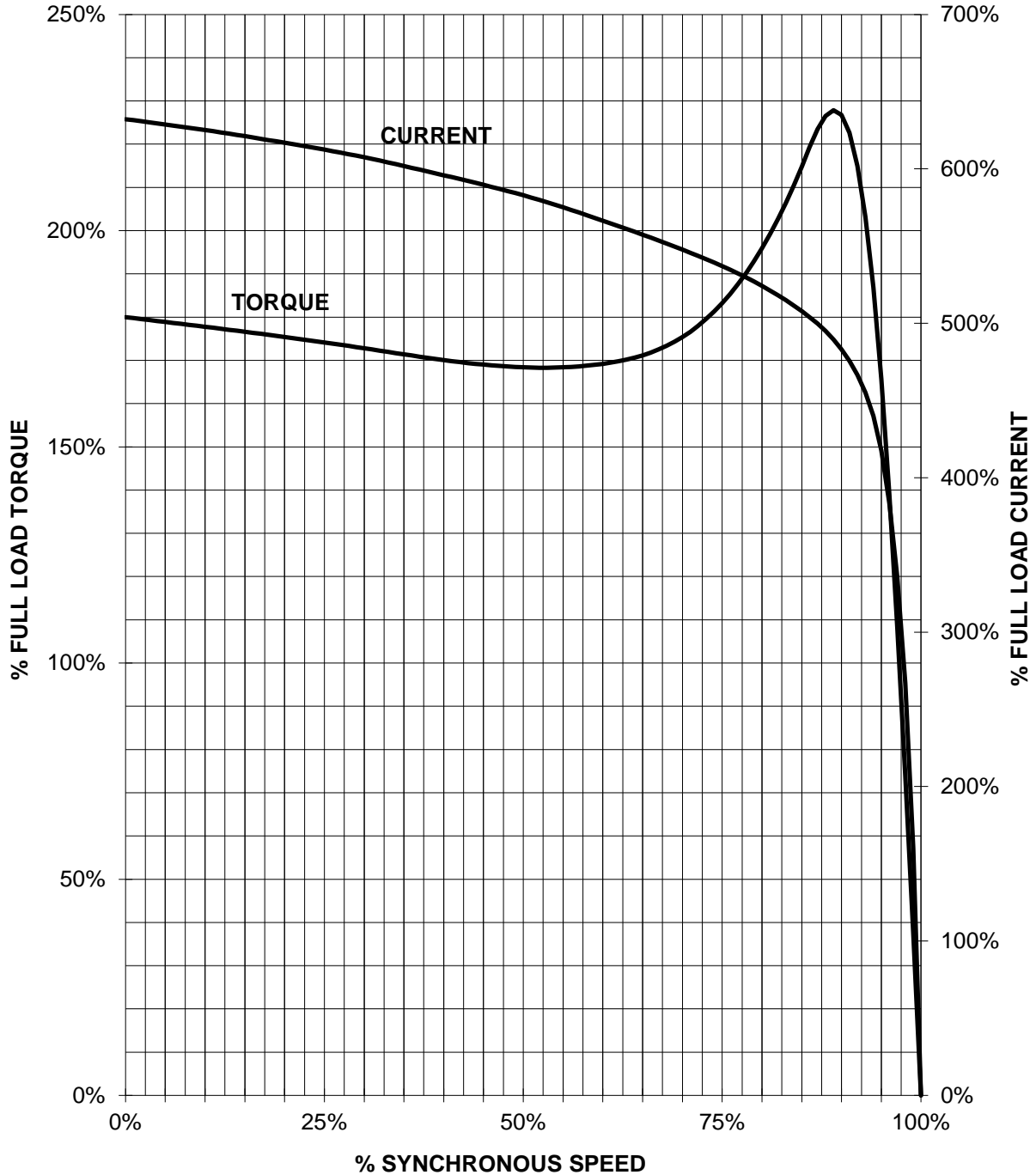

CUSTOMER: _____ ORDER#: _____

40 HP 1800 RPM 324T FRAME 575 VOLTS 3 PHASE NEMA DESIGN B

SIEMENS INDUSTRY, INC.
PERFORMANCE CURVE
XP100 1D1

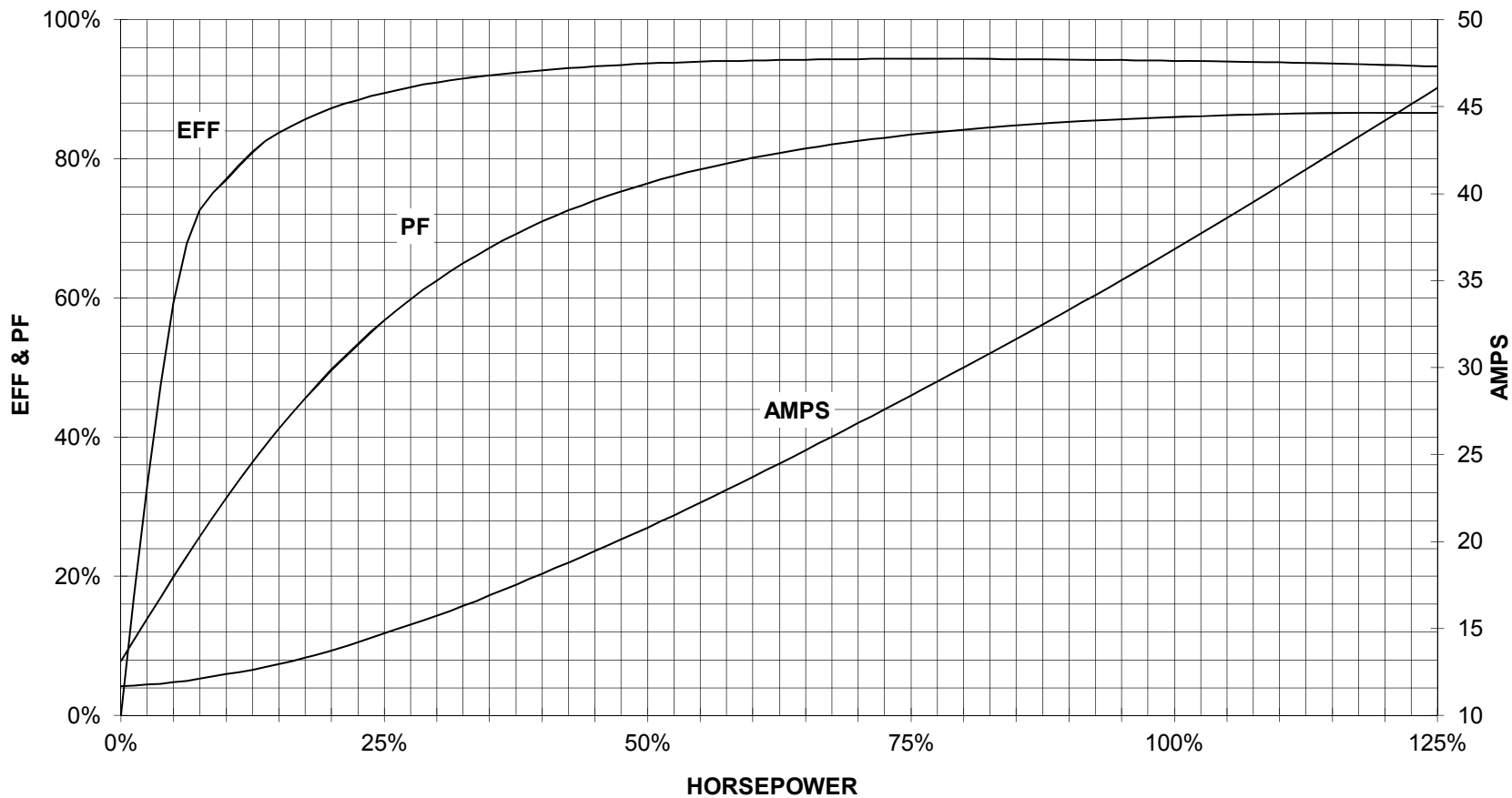

CUSTOMER: _____ ORDER #: _____

PERFORMANCE BASED ON DESIGN CALCULATIONS. SUBJECT TO CHANGE WITHOUT NOTICE.

REV. 1