

Data sheet for three-phase Squirrel-Cage-Motors SIMOTICS

Motor type: FS: 364T - 4p - 60 hp -

Client order no.	Item-No.	Offer no.
Order no.	Consignment no.	Project

Remarks

Electrical data Class I Division 1 Groups D

U [V]	Δ/Y	f [Hz]	P [HP]	P [kW]	n [rpm]	I Load [Amps]					Nom. Eff Load [%]			Pwr. Factor Load [%]			Torque [lb-ft]	T _A /T _N LRT [%]	T _k /T _N BDT [%]
						4/4	3/4	1/2	0	LRC	4/4	3/4	2/4	4/4	3/4	2/4			
460		60	60.00	-/-	1,780	68.00	52.00	38.30	19.00	435.0	95.0	95.4	95.2	87.0	85.0	77.0	177.0	180	240
230		60	60.00	-/-	1,780	136.00					95.0	95.4	95.2	87.0	85.0	77.0	177.0	180	240

Frame Type: 364T	Type of constr.: (A) Foot mounted - End shield	Ins. Cl.: Insulation class F	Motor Prot.: (A) No winding protection	NEMA Des.: B	S.F.: 1.15
Mtr. WT: 890		Temp. Rise Cl.: B	Amb. Temp.: + to -20 °C @1000 m	kVA: G	IP IP65

Mechanical data

Sound level (SPL / SWL) at 60 Hz	64.0 dB(A) / 75.0 dB(A)	Thickener	Polyurea
Octave Band Center Frequencies Hertz	250 500 1000 2000 4000 8000 Hz	Safe Stall Time Hot	26 s
SPL@3		Safe Stall Time Cold	38 s
Moment of inertia	16.9 Lb-ft ²	Frame material	cast iron
Ext Load Inertia Capability:	275.0 Lb ft ²	Color, paint shade	
Bearings		Coating (paint finish)	
Bearing DE NDE	6314 Z C3 S0 6314 Z C3 S0	Ventilation Type	
Bearing_Type	Ball Bearing Ball Bearing	Method of cooling	TEFC
AFBMA:	70BC03JP30 70BC03JP30	Direction of rotation	Bidirectional
Grease		Fan Material	Polypropylen ESD
Capacity	7.5 oz 7.5 oz	VFD	CT: 4:1 VT: 20:1
Grease Type:	Exxon Mobile EM	Space heaters	without
		Brake:	-/-

Terminal box

Lead Wire Connection	9 LEAD - DELTA	Terminal box position	(3) Mounting - F-1
Voltage	L1 L1 L1 Connected together	Material of terminal box	
LOW	T1 T7 T6 T2 T8 T4 T3 T9 T5 ---	Cable entry	-/-
HIGH	T1 T2 T3 T4 T7-T5 T8-T6 T9		

Notes:
 I_L/I_N = locked rotor current / current nominal
 M_L/M_N = locked rotor torque / torque nominal
 M_d/M_N = break down torque / nominal torque
 3) Value is valid only for DOL operation with motor design IC411
 2) at rated power / at full load

responsible dep. DI MC LVM	technical reference	created by DT Configurator	approved by	<i>Technical data are subject to change! There may be discrepancies between software and hardware versions.</i>
-------------------------------	---------------------	-------------------------------	-------------	---

	document type datasheet	document status released	customer	
	title 1MB2221-3CB11-6AA3	document number	rev.	creation date
© Siemens AG 2022		01	2022-04-08 22:24	language Page en 1/1

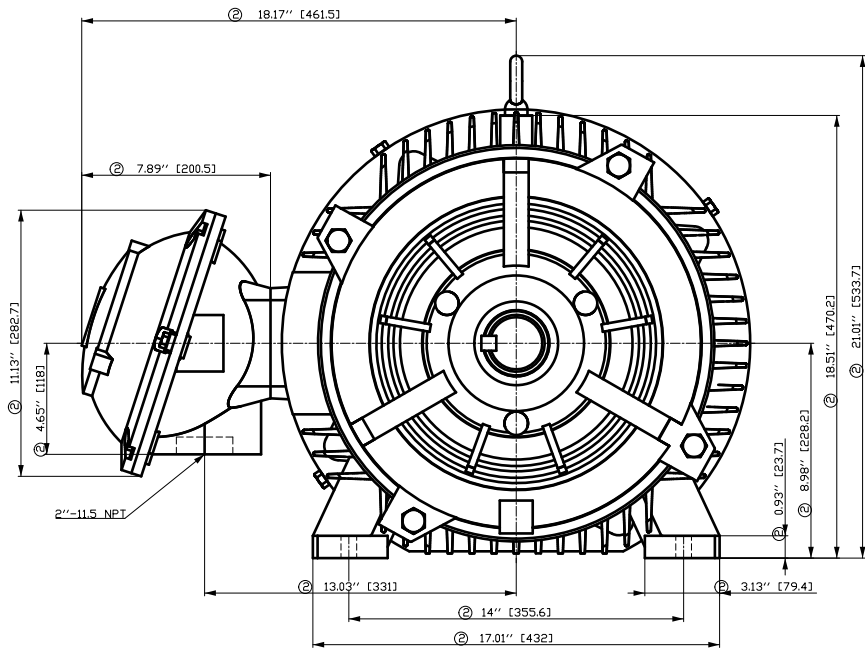

- ① Tolerances according to NEMA std.
- ② All these dimensions corresponding to assemblies and castings shall have a tolerance as per DIN standard 1686-GTB 19.
- ③ Not according to NEMA std.

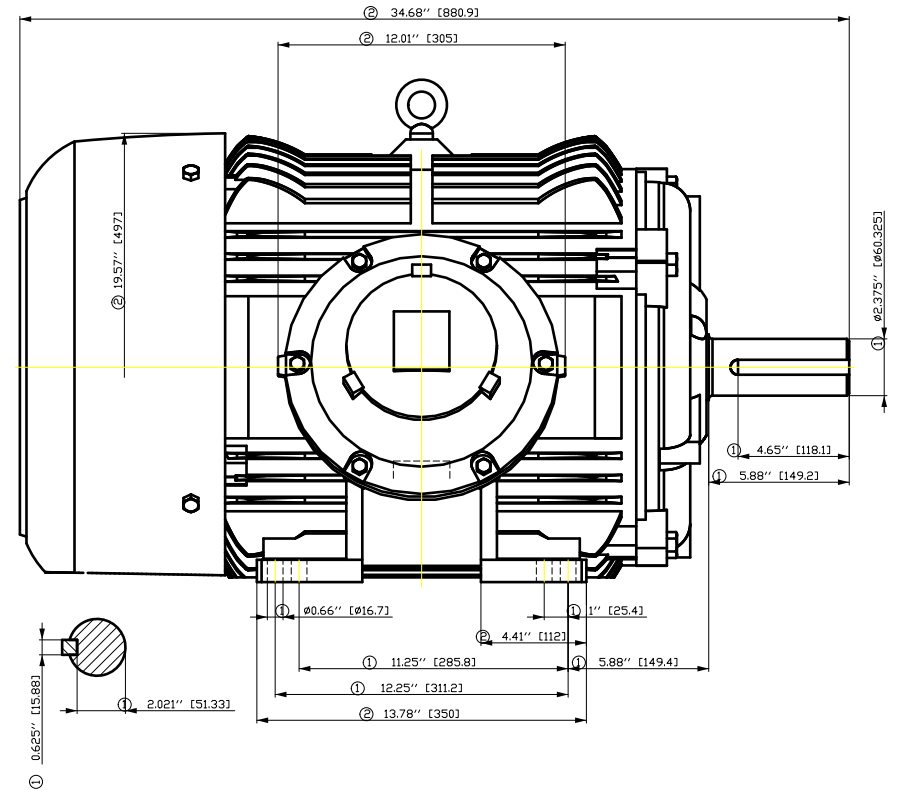

Tolerance	Surface	Material	Weight	Scale	
FT ÖGGRF#ÖÖFF# ÖEIH	Author	Öä ^}•ä }ä/ä ä *	E		
E	Creator				ÖVS
	Approval				T ä : ^ä@` } *
	Department				
	Change Order	MFB	Doc Type	/	
	Doc State	I ð ÖG	Item No	Paper Size	
	Revision	Index	RS	1st Language	
				2nd Language	
© Siemens AG	Project No	E	Ref No	E	
2018				Sheet F of F	

Main terminal diagram



9 LEAD DELTA						
Volts	LINES			CONNECTED TOGETHER	CONN.	
	L1	L2	L3			
LOW	T1 T6	T7 T4	T8 T5	T3 T9		Δ Δ
HIGH	T1	T2	T3	T4 T7-T5 T8-T6 T9		Δ

responsible dep. DI MC LVM	technical reference	created by	approved by	Project
SIEMENS	document type Wiring Diagram	document status free		customer
	title 1MB2221-3CB11-6AA3	document number		
© Siemens AG 2019	rev. 01	creation date 12/03/2019	language en	Page 1/1

SIEMENS INDUSTRY, INC.

HP 60 VOLTS <600 RPM 1800 TYPE XP100 1D1
HZ 60 PHASE 3 FRAME 364T NEMA B

TORQUE & CURRENT VS. SPEED

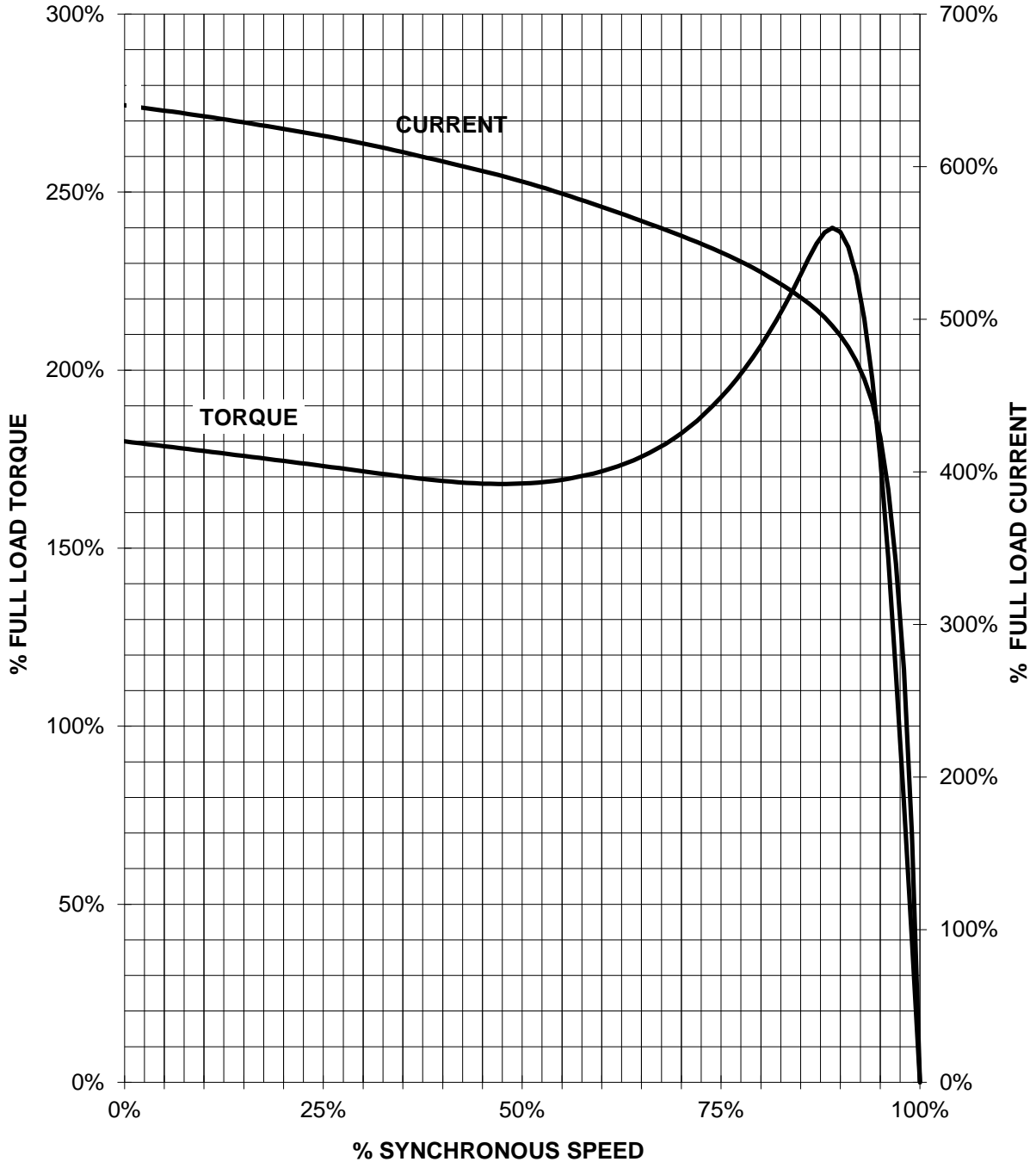

CUSTOMER: _____ ORDER#: _____

60 HP 1800 RPM 364T FRAME 460 VOLTS 3 PHASE NEMA DESIGN B

SIEMENS INDUSTRY, INC.
PERFORMANCE CURVE
XP100 1D1

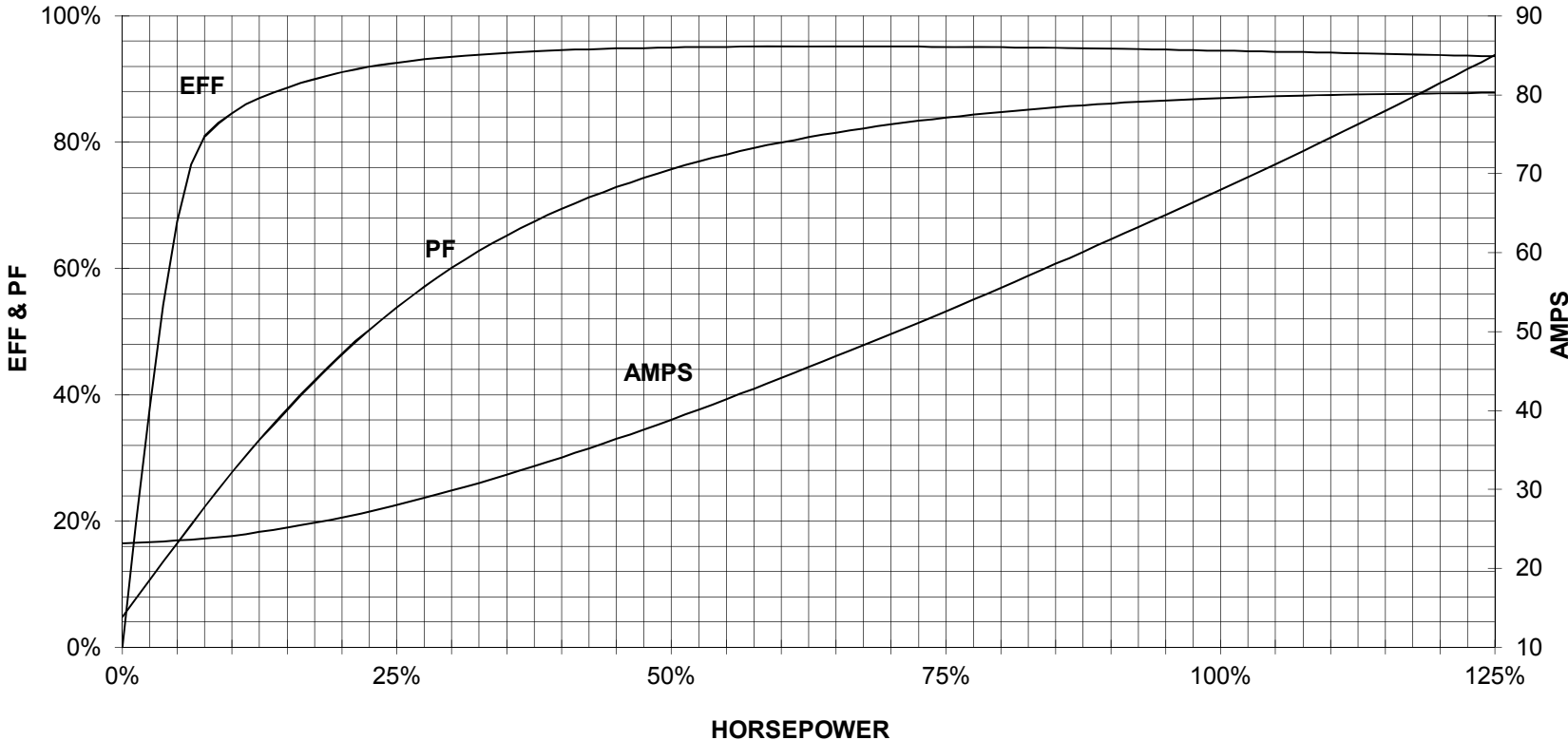

CUSTOMER: _____ ORDER #: _____

PERFORMANCE BASED ON DESIGN CALCULATIONS. SUBJECT TO CHANGE WITHOUT NOTICE.