

Data sheet for three-phase Squirrel-Cage-Motors SIMOTICS

Motor type: FS: 444T - 4p - 125 hp -

Client order no.	Item-No.	Offer no.
Order no.	Consignment no.	Project

Remarks

Electrical data **Class I Division 1 Groups D**

U [V]	Δ/Y	f [Hz]	P [HP]	P [kW]	n [rpm]	I Load [Amps]					LRC	Nom. Eff Load [%]			Pwr. Factor Load [%]			Torque [lb-ft]	T _A /T _N LRT [%]	T _k /T _N BDT [%]
						4/4	3/4	1/2	0	4/4		3/4	2/4	4/4	3/4	2/4				
460		60	125.00	-/-	1,785	143.00	109.30	78.60	45.00	908.0	95.4	95.6	95.4	86.0	84.0	78.0	368.0	160	200	

Frame Type: 444T	Type of constr.: (A) Foot mounted - End shield	Ins. Cl.:Insulation class F	Motor Prot.:(A) No winding protection	NEMA Des.: B	S.F.: 1.15
Mtr. WT:1,659		Temp. Rise Cl.: B	Amb. Temp.: + to -20 °C @1000 m	kVA: G	IP IP65

Mechanical data

Sound level (SPL / SWL) at 60 Hz	75.0 dB(A) / 86.0 dB(A)	Thickener	Polyurea
Octave Band Center Frequencies Hertz	250 500 1000 2000 4000 8000 Hz	Safe Stall Time Hot	20 s
SPL@3	dB(A)	Safe Stall Time Cold	25 s
Moment of inertia	24.7 Lb-ft ²	Frame material	cast iron
Ext Load Inertia Capability:	542.0 Lb ft ²	Color, paint shade	
Bearings		Coating (paint finish)	
Bearing DE NDE	NU 318 6316 Z C3 S0	Ventilation Type	
Bearing_Type	Roller Bearing Ball Bearing	Method of cooling	TEFC
AFBMA:	90RU03M0 80BC03JP30	Direction of rotation	Bidirectional
Grease		Fan Material	Polypropylen ESD
Capacity	14.5 oz 7.5 oz	VFD	CT: 4:1 VT: 20:1
Grease Type:	Exxon Mobile EM	Space heaters	without
		Brake:	-/-

Terminal box

Lead Wire Connection	6 LEAD - DELTA	Terminal box position	(3) Mounting - F-1
Voltage	L1 L1 L1 Connected together	Material of terminal box	
----	----	Cable entry	-/-
----	T1 T2 T3		

Notes:

I_r/I_N = locked rotor current / current nominal
M_r/M_N = locked rotor torque / torque nominal
M_b/M_N = break down torque / nominal torque

3) Value is valid only for DOL operation with motor design IC411
2) at rated power / at full load

responsible dep.	technical reference	created by	approved by	<i>Technical data are subject to change! There may be discrepancies between software and hardware versions</i>
DI MC LVM		DT Configurator		

	document type	document status	customer	
	datasheet	released		
	title	document number		
	1MB2221-4CB11-2AA3			
© Siemens AG 2022		rev.	creation date	language Page
		01	2022-04-09 02:17	en 1/1

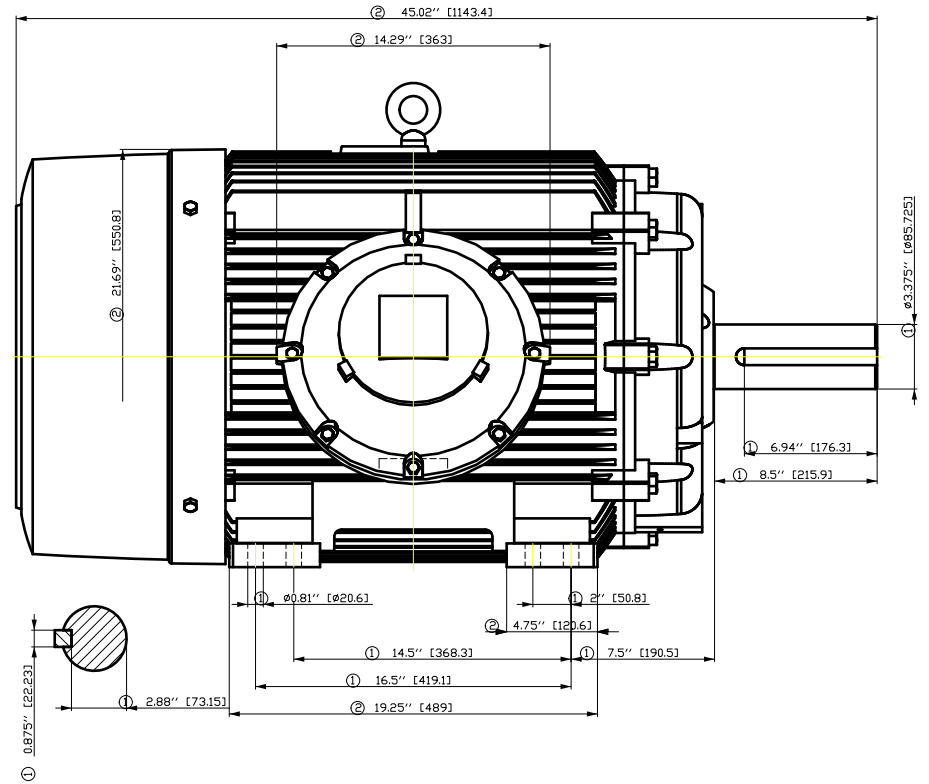
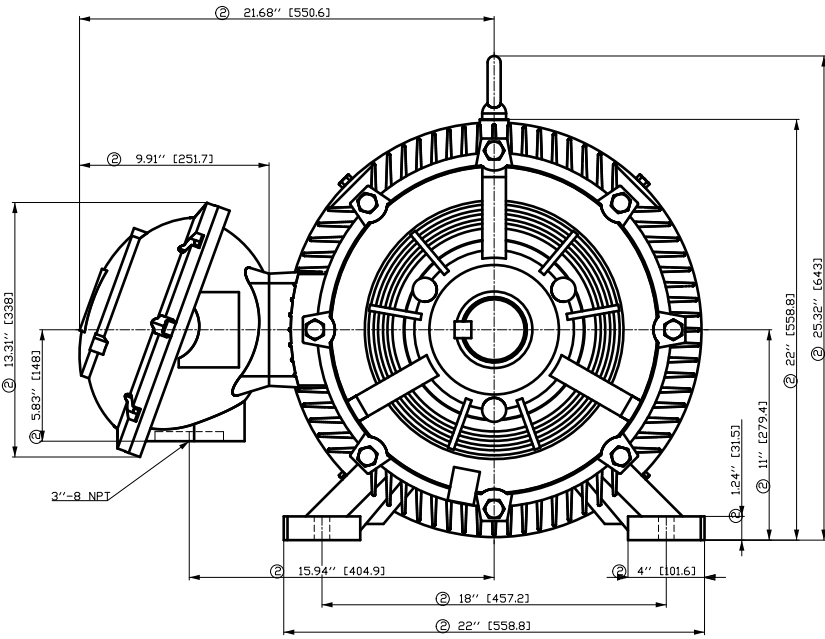

- ① Tolerances according to NEMA std.
- ② All these dimensions corresponding to assemblies and castings shall have a tolerance as per DIN standard 1686-GTB 19.
- ③ Not according to NEMA std.

Tolerance	Surface	Material	Weight	Scale
FT ÖGGRFË ÖÖFFËÖÖIH Ë	Author Creator Approval Department Change Order	ÖS T æ : ^æ@ } *	Ë	{ {
SIEMENS	Doc. State Revision	I Ë ÖG Index RS	MFB Item No Doc No	Doc Type Paper Size 1st Language 2nd Language
© Siemens AG 2018	Project No	Ë	Ref No	Ë
				Sheet F of F

Main terminal diagram

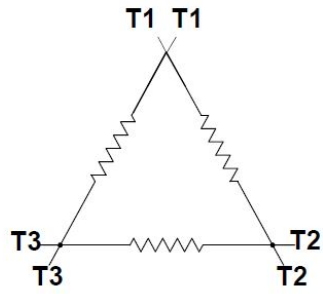

6 LEAD DELTA			
LINES			CONN.
L1	L2	L3	
T1	T2	T3	Δ

responsible dep.
DI MC LVM

technical reference

created by

approved by

Project

SIEMENS

document type
Wiring Diagram

title
1MB2221-4CB11-2AA3

document status
free

document number

customer

SIEMENS INDUSTRY, INC.

HP 125 VOLTS <600 RPM 1800 TYPE XP100 1D1
HZ 60 PHASE 3 FRAME 444T NEMA B

TORQUE & CURRENT VS. SPEED

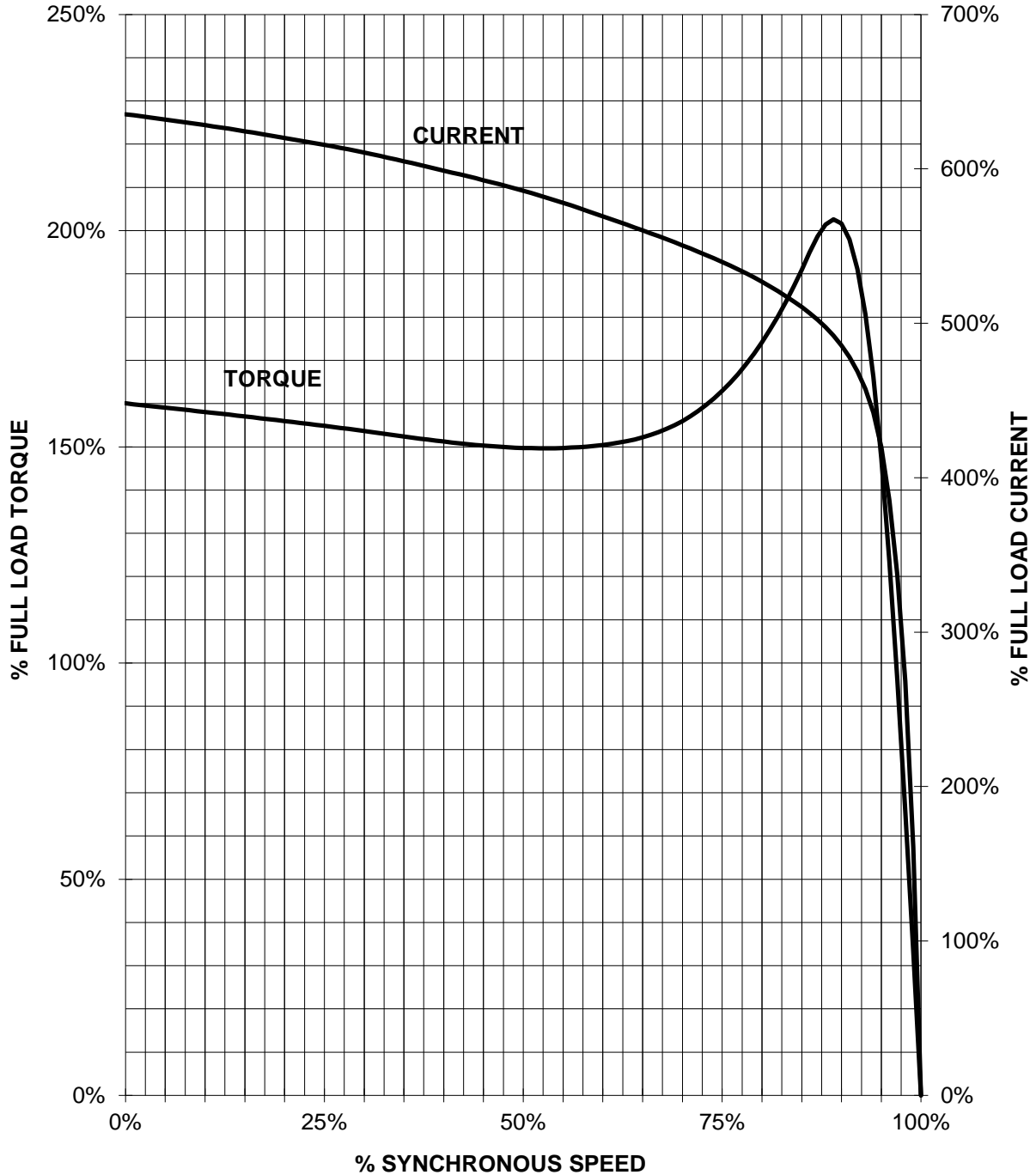

CUSTOMER: _____ ORDER#: _____

125 HP 1800 RPM 444T FRAME 460 VOLTS 3 PHASE NEMA DESIGN B

**SIEMENS INDUSTRY, INC.
PERFORMANCE CURVE
XP100 1D1**

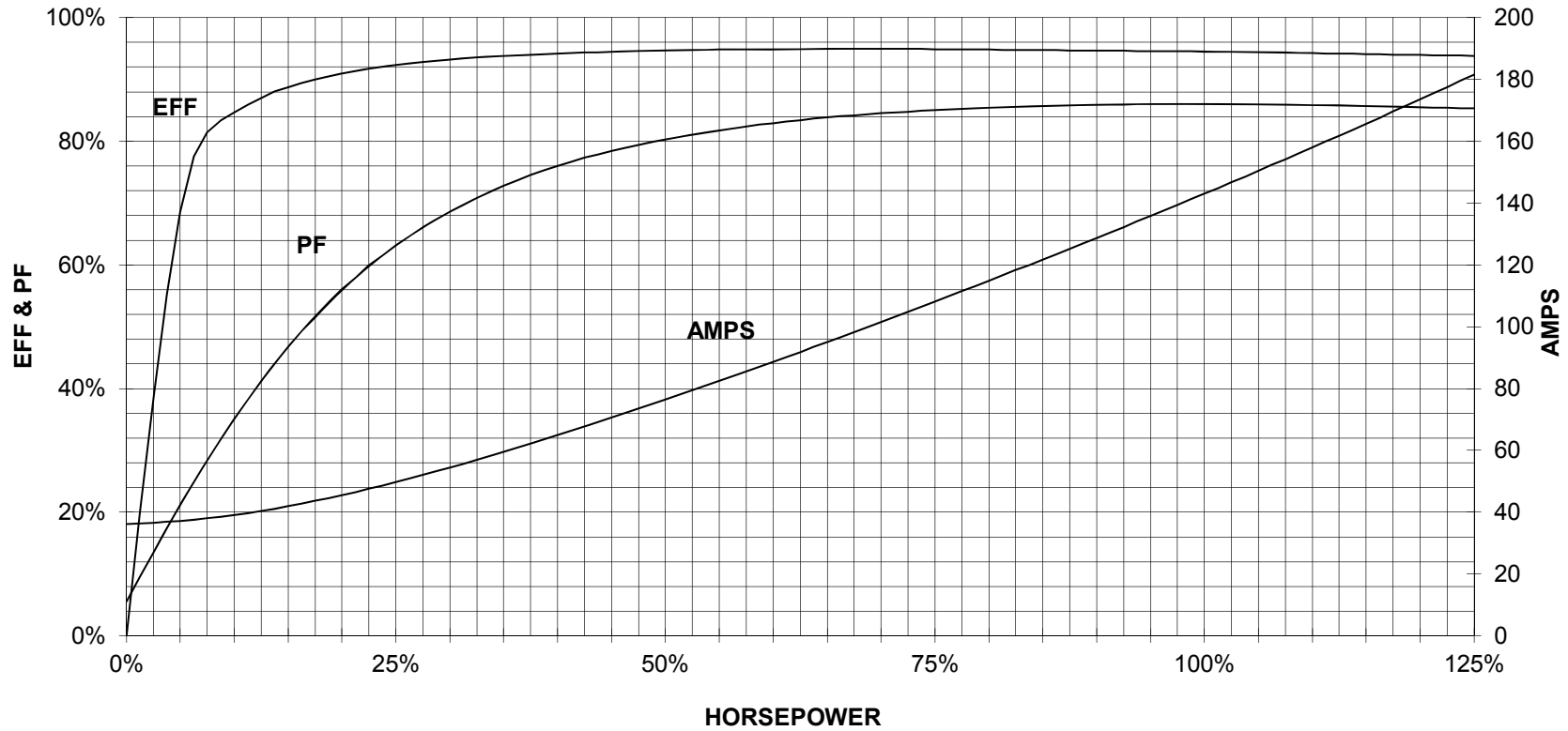

CUSTOMER _____ ORDER # _____ PO # _____

PERFORMANCE BASED ON DESIGN CALCULATIONS. SUBJECT TO CHANGE WITHOUT NOTICE.

REV. 1