

# Data sheet for three-phase Squirrel-Cage-Motors SIMOTICS

**Motor type:** FS: B444T - 6p - 100 hp -

Client order no.	Item-No.	Offer no.
Order no.	Consignment no.	Project
Remarks		

**Electrical data** Class I Division 1 Groups D

U [V]	$\Delta/Y$	f [Hz]	P [HP]	P [kW]	n [rpm]	I Load [Amps]					Nom. Eff Load [%]			Pwr. Factor Load [%]			Torque [lb-ft]	T <sub>A</sub> /T <sub>N</sub> LRT [%]	T <sub>k</sub> /T <sub>N</sub> BDT [%]
						4/4	3/4	1/2	0	LRC	4/4	3/4	2/4	4/4	3/4	2/4			
460		60	100.00	-/-	1,185	117.00	91.00	67.40	39.00	725.0	95.0	95.3	95.1	84.0	81.0	73.0	443.0	160	200
230		60	100.00	-/-	1,185	234.00					95.0	95.3	95.1	84.0	81.0	73.0	443.0	160	200

Frame Type: B444T	Type of constr.: (A) Foot mounted - End shield	Ins. Cl.:Insulation class F	Motor Prot.:(A) No winding protection	NEMA Des.: B	S.F.: 1.15
Mtr. WT:1,513		Temp. Rise Cl.: B	Amb. Temp.: + to -20 °C @1000 m	kVA: G	IP IP65

**Mechanical data**

Sound level (SPL / SWL) at 60 Hz	65.0 dB(A) / 76.0 dB(A)	Thickener	Polyurea
Octave Band Center Frequencies Hertz	250 500 1000 2000 4000 8000 Hz	Safe Stall Time Hot	30 s
SPL@3	dB(A)	Safe Stall Time Cold	35 s
Moment of inertia	46.0 Lb-ft <sup>2</sup>	Frame material	cast iron
Ext Load Inertia Capability:	1180.0 Lb ft <sup>2</sup>	Color, paint shade	
<b>Bearings</b>		Coating (paint finish)	
Bearing DE   NDE	6318 Z C3 S0   6316 Z C3 S0	<b>Ventilation Type</b>	
Bearing_Type	Ball Bearing   Ball Bearing	Method of cooling	TEFC
AFBMA:	90BC03JP30   80BC03JP30	Direction of rotation	Bidirectional
<b>Grease</b>		Fan Material	Polypropylen ESD
Capacity	14.5 oz   7.5 oz	VFD	CT: 4:1 VT: 20:1
Grease Type:	Exxon Mobile EM	Space heaters	without
		Brake:	-/-

**Terminal box**

Lead Wire Connection	9 LEAD - DELTA	Terminal box position	(3) Mounting - F-1
Voltage	L1 L1 L1 Connected together	Material of terminal box	
LOW	T1 T7 T6 T2 T8 T4 T3 T9 T5 - - - -	Cable entry	-/-
HIGH	T1 T2 T3 T4 T7-T5 T8-T6 T9		

<b>Notes:</b>			
I <sub>r</sub> /I <sub>N</sub> = locked rotor current / current nominal	M <sub>r</sub> /M <sub>N</sub> = locked rotor torque / torque nominal	M <sub>b</sub> /M <sub>N</sub> = break down torque / nominal torque	3) Value is valid only for DOL operation with motor design IC411 2) at rated power / at full load

responsible dep.	technical reference	created by	approved by	<i>Technical data are subject to change! There may be discrepancies between software and customer interface</i>
DI MC LVM		DT Configurator		

	document type	document status	customer	
	datasheet	released		
	title	document number		
	1MB2221-4EC11-6AA3			
© Siemens AG 2022		rev.	creation date	language Page
		01	2022-04-09 02:26	en 1/1

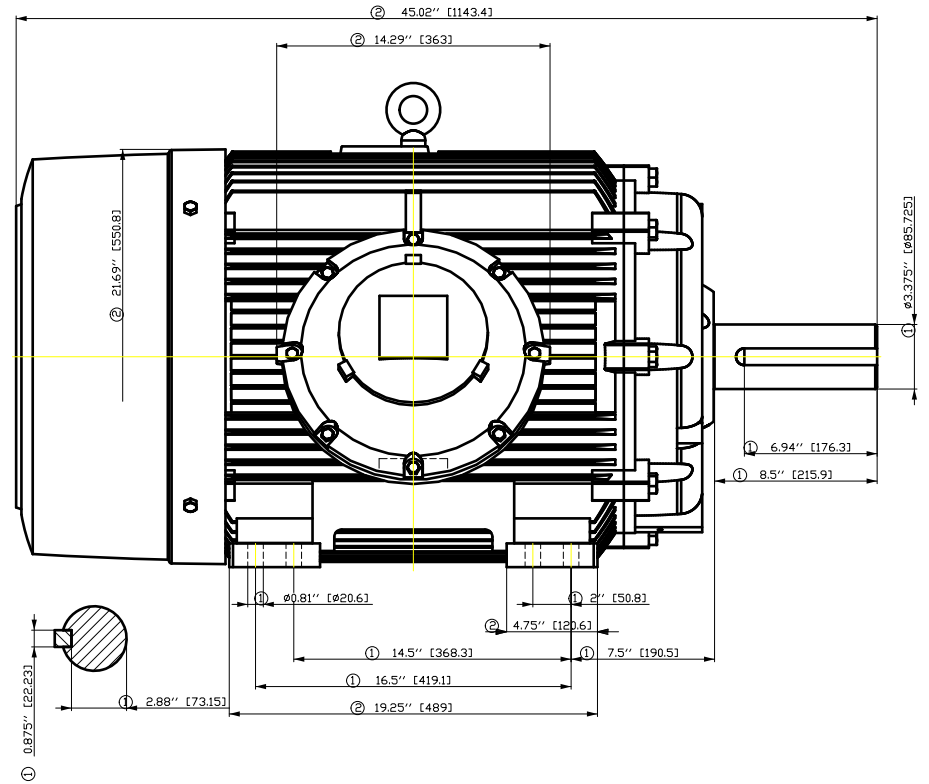
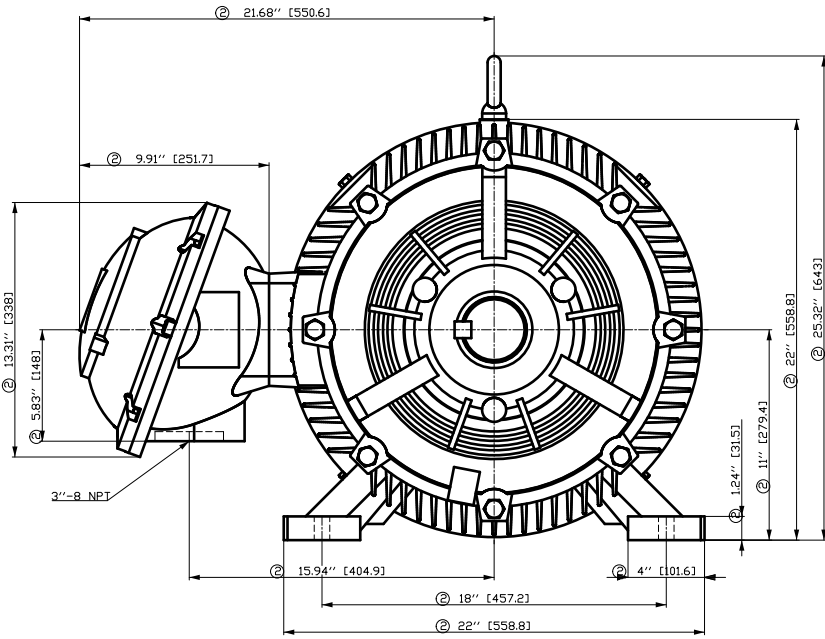

- ① Tolerances according to NEMA std.
- ② All these dimensions corresponding to assemblies and castings shall have a tolerance as per DIN standard 1686-GTB 19.
- ③ Not according to NEMA std.

Tolerance	Surface	Material	Weight	Scale	
FT ÖGGGFÈ ÖÖFFÈ ÖEIH	Author	ÖS T æ : ^ & @ } *	E		
E	Creator				ÖVS
	Approval				
	Department				
	Change Order	MFB	Doc Type	/	
	Doc. State	I EGG	Item No	Paper Size	
	Revision	Index	RS	1st Language	
				2nd Language	
© Siemens AG 2018	Project No	E	Ref No	E	
				Sheet F of F	

Main terminal diagram

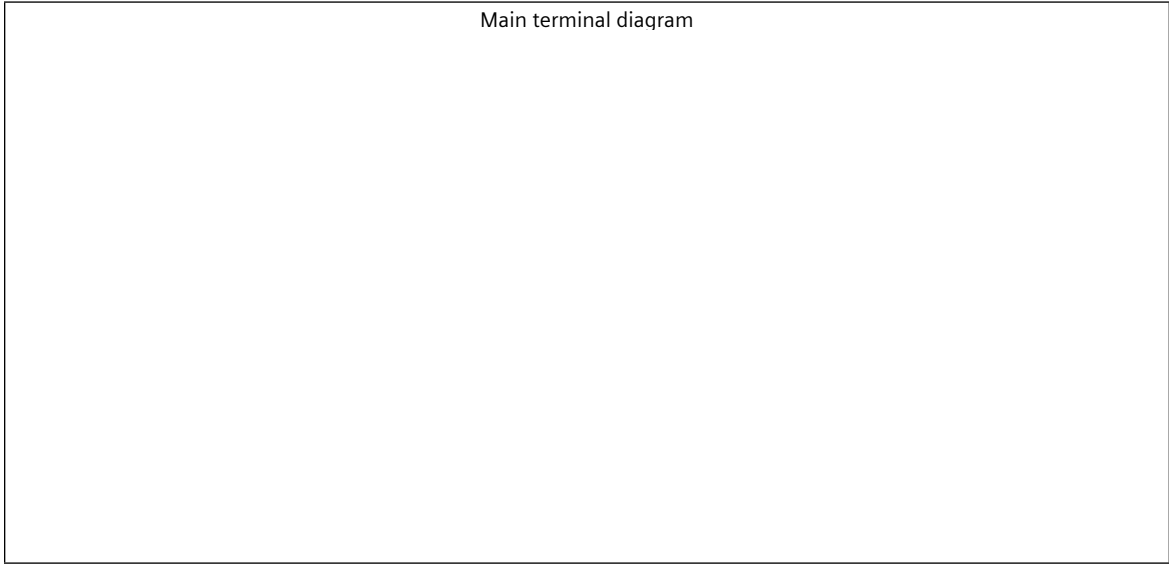

responsible dep. DI MC LVM	technical reference	created by	approved by	Project			
	document type Wiring Diagram			document status free		customer	
	title 1MB2221-4EC11-6AA3			document number			
© Siemens AG 2019				rev. 01	creation date 12/03/2019	language en	Page 1/1

# SIEMENS INDUSTRY, INC.

HP 100    VOLTS <600    RPM 1200    TYPE XP100 1D1  
HZ 60    PHASE 3    FRAME B444T    NEMA B

## TORQUE & CURRENT VS. SPEED

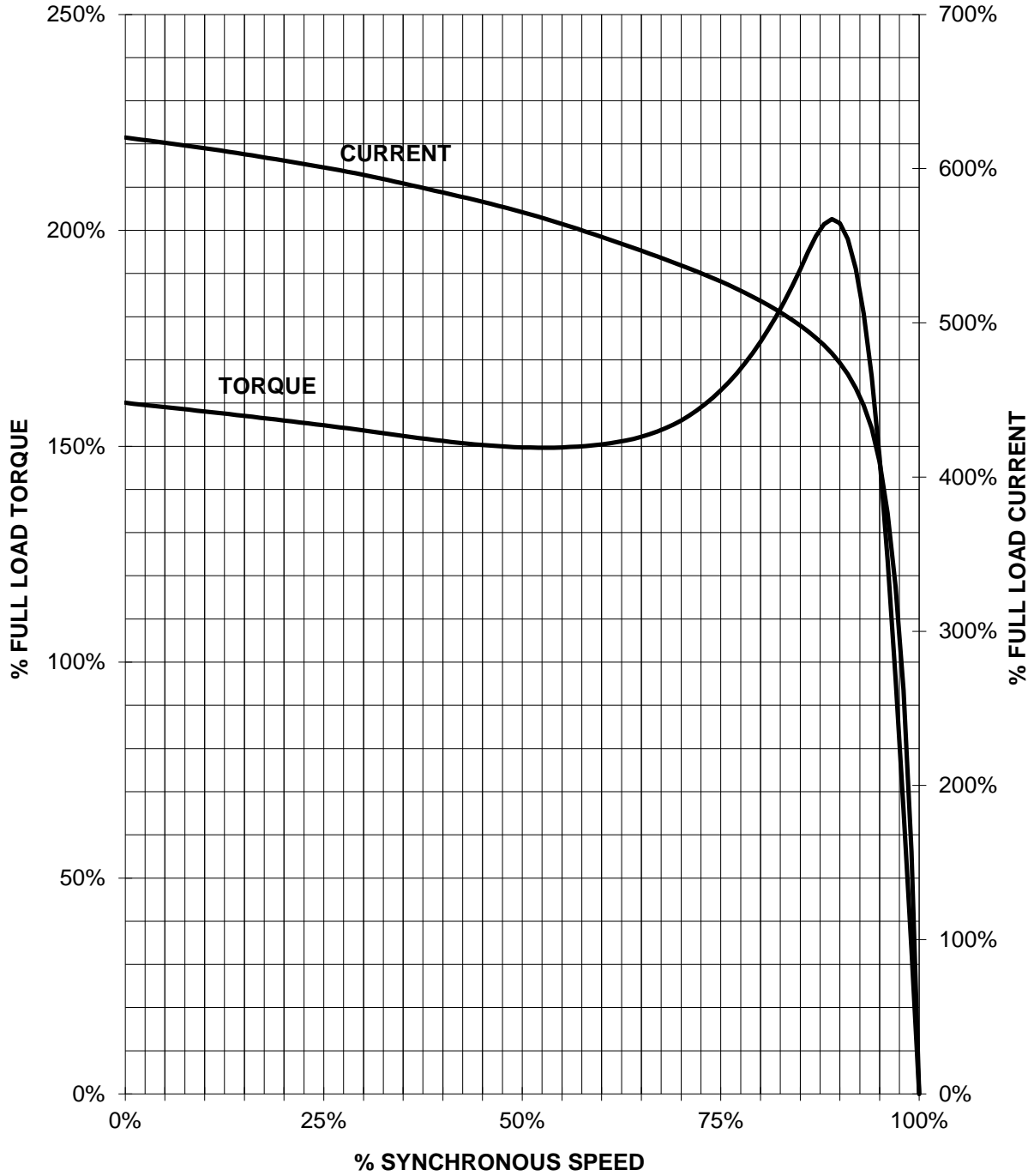

CUSTOMER: \_\_\_\_\_ ORDER#: \_\_\_\_\_

100 HP 1200 RPM B444TS FRAME 460 VOLTS 3 PHASE NEMA DESIGN B

**SIEMENS INDUSTRY, INC.**  
**PERFORMANCE CURVE**  
**XP100 1D1**

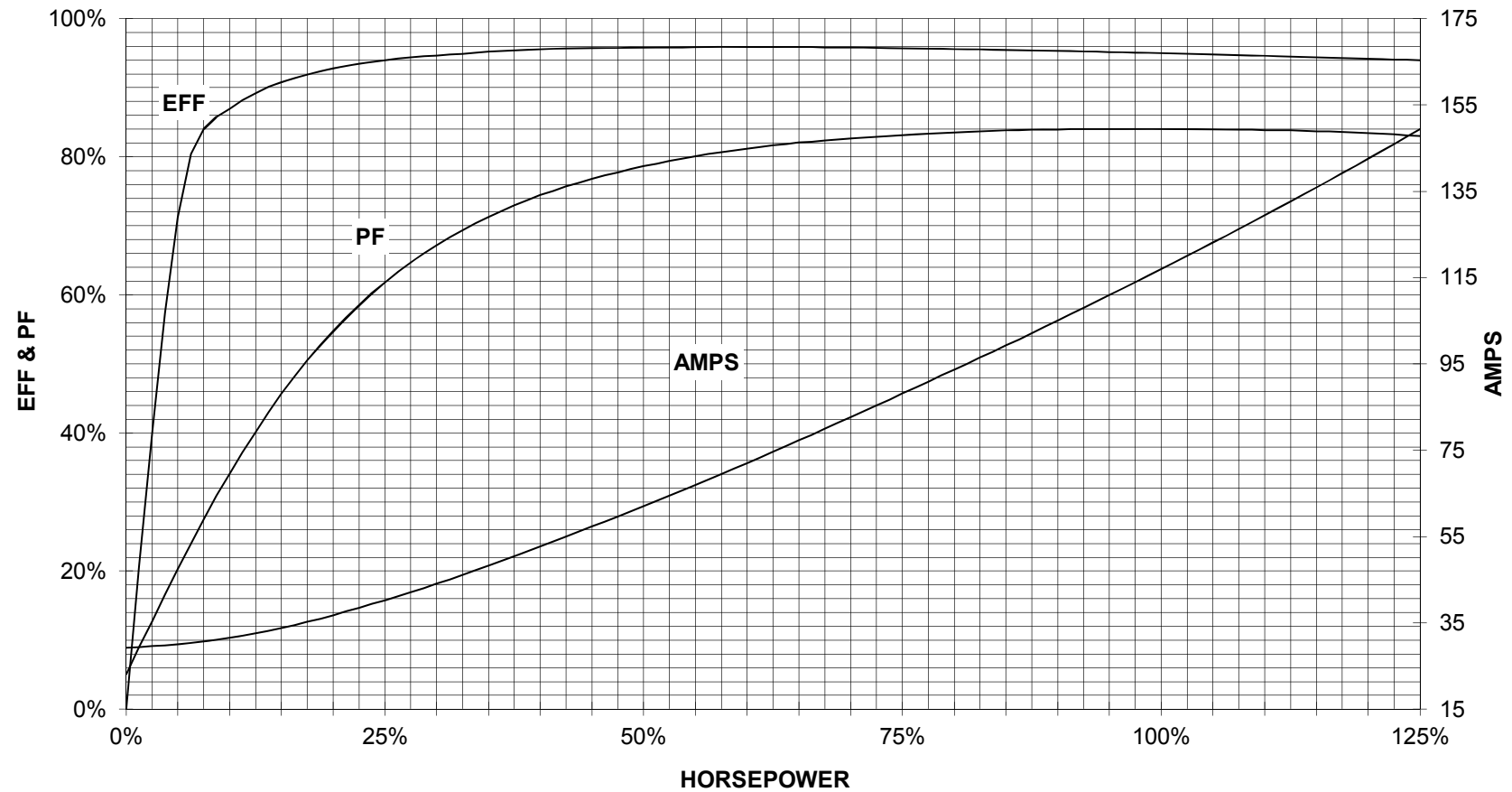

CUSTOMER \_\_\_\_\_ ORDER # \_\_\_\_\_ PO # \_\_\_\_\_

PERFORMANCE BASED ON DESIGN CALCULATIONS. SUBJECT TO CHANGE WITHOUT NOTICE.

REV. 1