

Data sheet for three-phase Squirrel-Cage-Motors SIMOTICS

Motor type: **DP200 HPS - Definite Purpose motor - NEMA Premium Efficiency**

FS: **5011S - 2p - 600 hp -**

Client order no.	Item-No.	Offer no.
Order no.	Consignment no.	Project

Remarks

Electrical data Class I Division 2 Gr. A, B, C or D T3

U [V]	Δ/Y	f [Hz]	P [HP]	P [kW]	n [rpm]	I Load [Amps]					Nom. Eff Load [%]			Pwr. Factor Load [%]			Torque [lb-ft]	T _A /T _N LRT [%]	T _k /T _N BDT [%]
						4/4	3/4	1/2	0	LRC	4/4	3/4	2/4	4/4	3/4	2/4			
460	$\Delta \Delta$	60	600.00	447.60	3,585	650	500.30	361.90	145.00	4250.0	96.7	96.8	96.3	89.1	87.0	80.6	877.7	190	230

Frame Type: 5011S	Type of constr.: (A) Foot Mounted Horizontal (IMB3)	Ins. Cl.: Standard Class H Insulation	Motor Prot.: A: No Winding Protection	NEMA Des.: -/-	S.F.: 1.15
Mtr. WT: 4,631		Temp. Rise Cl.: B	Amb. Temp.: + 40 to °C @1000 m	kVA: G	IP 55

Mechanical data

Sound level (SPL / SWL) at 60 Hz	82.0 dB(A) / 95.0 dB(A)		Thickener	Polyurea					
Octave Band Center Frequencies Hertz			Safe Stall Time Hot	17 s					
	250	500	1000	2000	4000	8000	Hz	Safe Stall Time Cold	22 s
SPL@3	79.0	74.0	73.0	72.0	72.0	67.0	dB(A)	Frame material	Cast iron
Moment of inertia	121.0 Lb-ft ²		Color, paint shade	RAL 7030					
Ext Load Inertia Capability:	443.0 Lb ft ²		Coating (paint finish)	Standard Alkyed + Epoxy (C2)					
Bearings			Ventilation Type						
Bearing DE NDE	6316 Z C3 S0		6316 Z C3 S0 insulated	Method of cooling	TEFC				
Bearing_Type	Ball Bearing		Ball Bearing	Direction of rotation	Bi-Directional				
AFBMA:	80BC03JP3		80BC03JP3	Fan Material	Polypropylene ESD				
Grease			VFD	CT: 4:1 VT: 20:1					
Capacity	9 oz		9 oz	Space heaters	without				
Grease Type:	Exxon Mobil EM		Brake:	-/-					

Terminal box

Lead Wire Connection	12 TERMINAL - Connection DELTA				Terminal box position	(1) LHS Mount - View From DE (F-1) - DE or Center of Motor
Voltage	L1	L1	L1	Connected together	Material of terminal box	Cast Iron
----	----	----	----	---	Cable entry	(1) 5" NPT
RUN	T12-T7-T6-T1	T10-T8-T4-T2	T11-T9-T5-T13	----		

Notes:

I_L/I_N = locked rotor current / current nominal
M_L/M_N = locked rotor torque / torque nominal
M_d/M_N = break down torque / nominal torque

3) Value is valid only for DOL operation with motor design IC411
2) at rated power / at full load

responsible dep.	technical reference	created by	approved by	<i>Technical data are subject to change! There may be discrepancies between software and customer interface</i>
DI MC LVM		DT Configurator		

	document type	document status		customer	
	datasheet	released			
	title	document number		rev.	creation date
	1PC6521-5EA01-2AA1			01	2022-04-08 01:04
© Siemens AG 2022		language	Page		
		en	1/1		

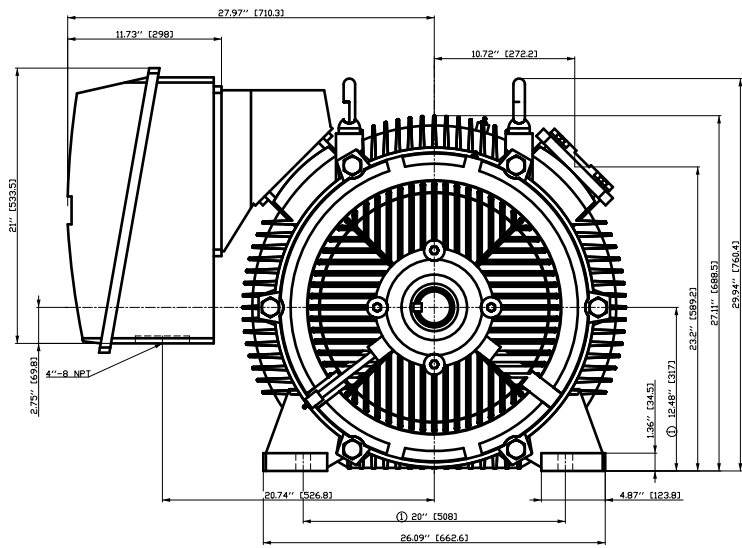

① Tolerances according to NEMA std.
 All dimensions corresponding to assemblies and castings shall have a tolerance as per ISD 8062-3 DCTG 12.

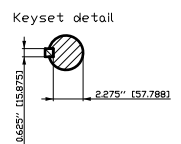
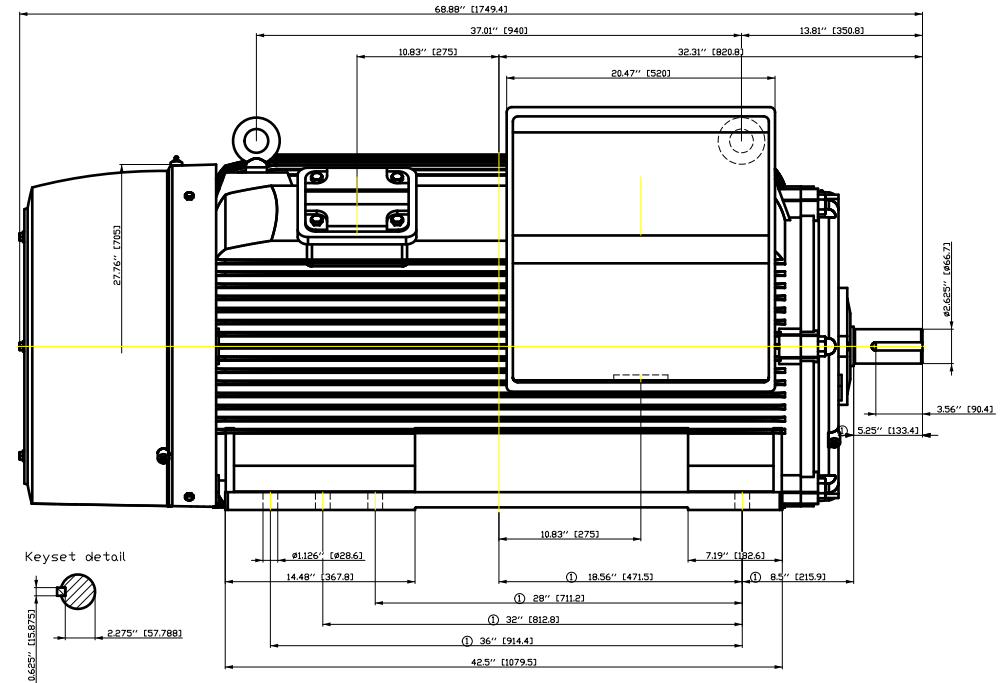

Tolerance	Surface	Material	Weight	Scale
FÜÖI i GFE ÖCEFEÖÖE	Author	Öä ^}•ä }ä/ä ä *	È	{ {
È	Creator	ÖVS		
	Approval	T ä : ^ä@` } *		
	Department			
	Change Order	MLFB		Doc Type
	Doc State	I ð ÖÖG		Paper Size
SIEMENS	Revision	Index	Item No	1st Language
© Siemens AG	2018	RS	Doc No	2nd Language
	Project No	È	Ref No	È
				Sheet F of F

Main terminal diagram

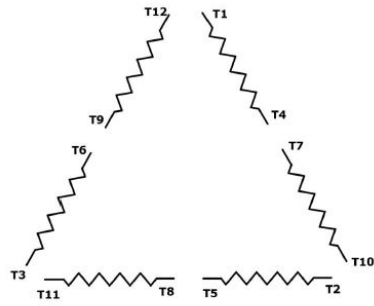

12 LEAD DELTA		
LINES	CONNECT TOGETHER	CONN.
L1	T12 - T7 - T6 - T1	ΔΔ
L2	T10 - T8 - T4 - T2	
L2	T11 - T9 - T5 - T3	

responsible dep. DI MC LVM	technical reference	created by	approved by	Project
SIEMENS	document type Wiring Diagram	document status free		customer
	title 1PC6521-5EA01-2AA1	document number		
© Siemens AG 2019		rev. 01	creation date 12/03/2019	language en Page 1/1