

Data sheet for three-phase Squirrel-Cage-Motors SIMOTICS

Motor type: DP200 HPS - Definite Purpose motor - NEMA Premium Efficiency

FS: 5013S - 2p - 700 hp -

Client order no.	Item-No.	Offer no.
Order no.	Consignment no.	Project
Remarks		

Electrical data

Class I Division 2 Gr. A, B, C or D T2D

U [V]	Δ/Y	f [Hz]	P [HP]	P [kW]	n [rpm]	I Load [Amps]					Nom. Eff Load [%]			Pwr. Factor Load [%]			Torque [lb-ft]	T _A /T _N LRT [%]	T _k /T _N BDT [%]
						4/4	3/4	1/2	0	LRC	4/4	3/4	2/4	4/4	3/4	2/4			
460	$\Delta \Delta$	60	700.00	522.20	3,585	750	568.80	399.60	160.00	5285.0	95.8	95.6	94.8	91.1	90.4	86.5	1025.5	250	290

Frame Type: 5013S	Type of constr.: (A) Foot Mounted Horizontal (IMB3)	Ins. Cl.: Standard Class H Insulation	Motor Prot.: A: No Winding Protection	NEMA Des.: -/-	S.F.: 1.15
Mtr. WT: 5,538		Temp. Rise Cl.: B	Amb. Temp.: + 40 to °C @1000 m	kVA: G	IP 55

Mechanical data

Sound level (SPL / SWL) at 60 Hz	93.0 dB(A) / 106.0 dB(A)							Thickener	Polyurea
Octave Band Center Frequencies Hertz								Safe Stall Time Hot	23 s
	250	500	1000	2000	4000	8000	Hz	Safe Stall Time Cold	28 s
SPL@3	87.0	77.0	76.0	75.0	75.0	70.0	dB(A)	Frame material	Cast iron
Moment of inertia	152.0 Lb-ft ²							Color, paint shade	RAL 7030
Ext Load Inertia Capability:	503.0 Lb ft ²							Coating (paint finish)	Standard Alkyed + Epoxy (C2)
Bearings								Ventilation Type	
Bearing DE NDE	6316 Z C3 S0			6316 Z C3 S0 insulated				Method of cooling	TEFC
Bearing_Type	Ball Bearing			Ball Bearing				Direction of rotation	Bi-Directional
AFBMA:	80BC03JP3			80BC03JP3				Fan Material	Polypropylene ESD
Grease								VFD	CT: 4:1 VT: 20:1
Capacity	9 oz			9 oz				Space heaters	without
Grease Type:	Exxon Mobil EM							Brake:	-/-

Terminal box

Lead Wire Connection	12 TERMINAL - Connection DELTA					Terminal box position	(1) LHS Mount - View From DE (F-1) - DE or Center of Motor
Voltage	L1	L1	L1	Connected together		Material of terminal box	Cast Iron
---	---	---	---	---	-	Cable entry	(1) 5" NPT
RUN	T12-T7-T6-T1	T10-T8-T4-T2	T11-T9-T5-T13	---	$\Delta \Delta$		



Notes:
 I_L/I_N = locked rotor current / current nominal
 M_L/M_N = locked rotor torque / torque nominal
 M_d/M_N = break down torque / nominal torque
 3) Value is valid only for DOL operation with motor design IC411
 2) at rated power / at full load

responsible dep. DI MC LVM	technical reference	created by DT Configurator	approved by	<i>Technical data are subject to change! There may be discrepancies between software and hardware versions.</i>			
	document type datasheet	document status released		customer			
	title 1PC6521-5FA71-2AA1	document number					
© Siemens AG 2022	rev. 01	creation date 2022-04-08 01:07	language en	Page 1/1			

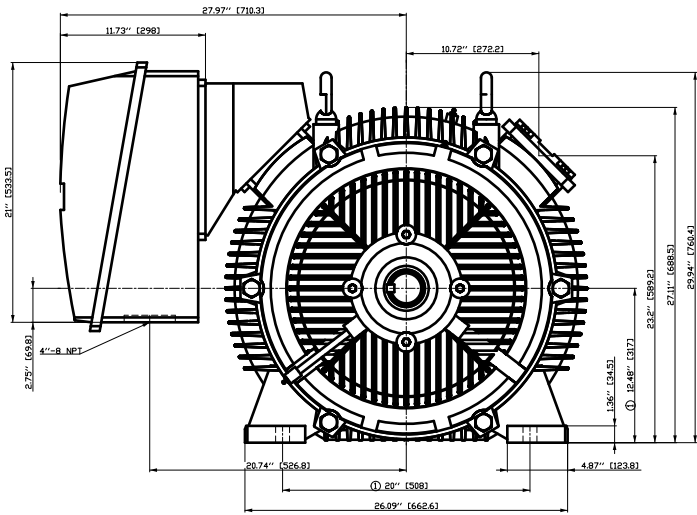

① Tolerances according to NEMA std.
 All dimensions corresponding to assemblies and castings shall have a tolerance as per ISD 8062-3 DCTG 12.

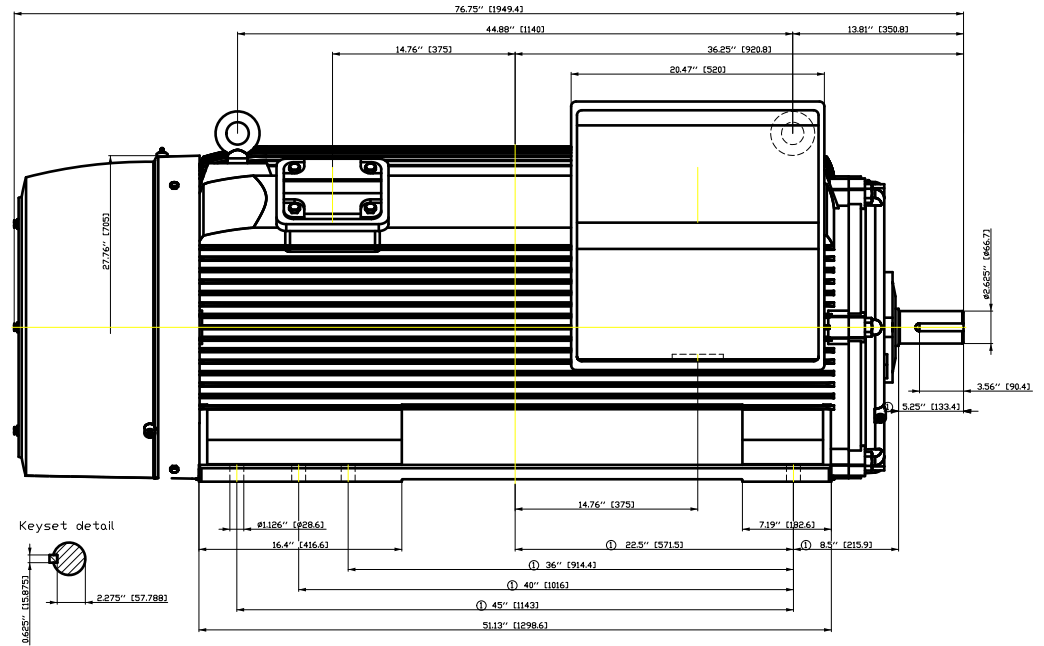

Keyset detail

Tolerance	Surface	Material	Weight	Scale
FÜÖI i G-E ÜÖE FÜÖÖE É	Author Creator Approval Department Change Order	ÖS T æ : ^æ@` } *	É	{ } { } { }
SIEMENS © Siemens AG 2018	Doc. State	I ÜÖÖG	MFB	Doc Type
	Revision	Index RS	Item No	Paper Size CH
	Project No	É	Doc No	1st Language ^ } 2nd Language â ^
		Ref No	É	Sheet F of F

SIEMENS INDUSTRY, INC.

HP 700 VOLTS 460 RPM 3585 TYPE SD200
HZ 60 PHASE 3 FRAME 5013S NEMA _____

TORQUE & CURRENT VS. SPEED

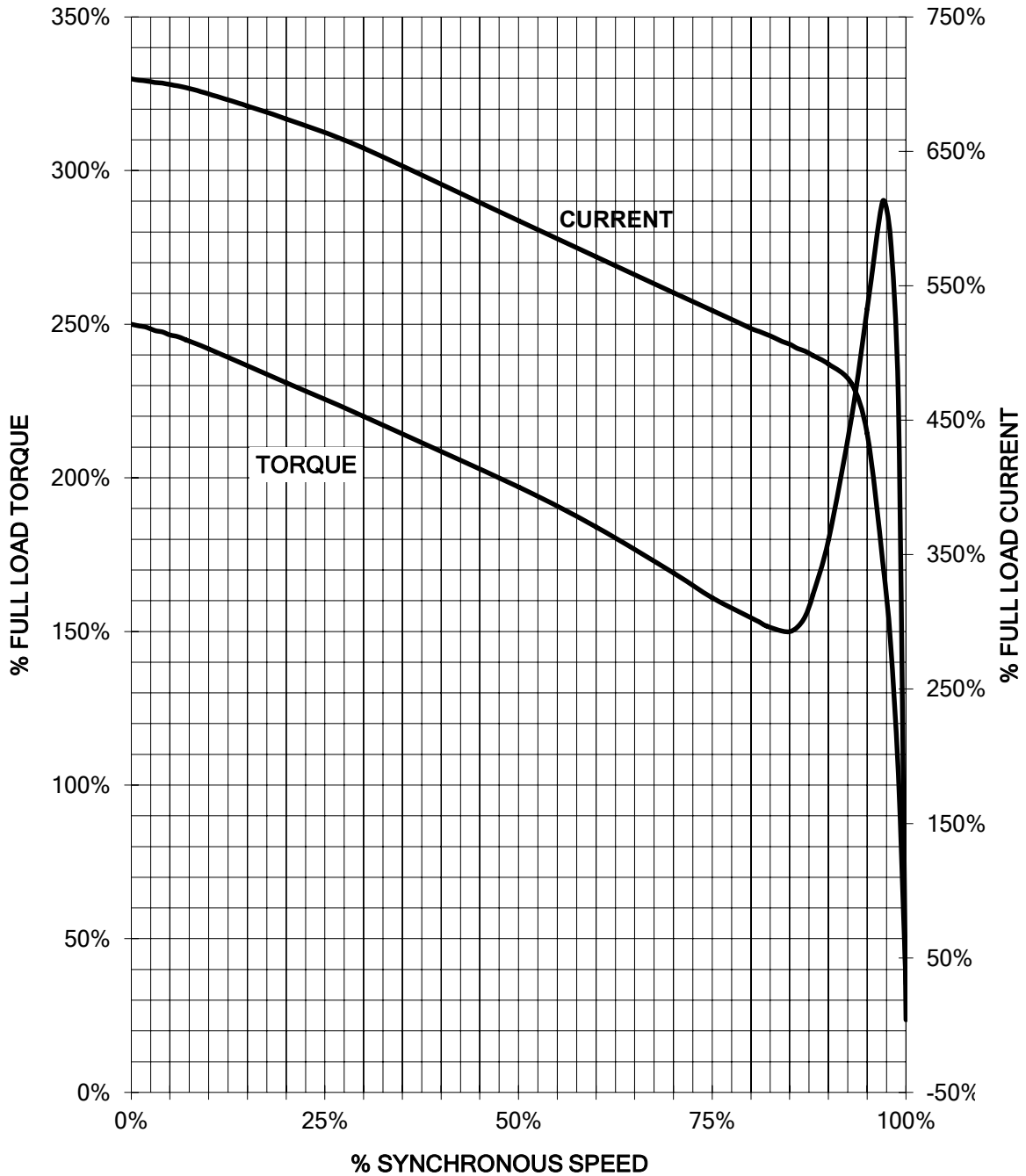

Unrestricted CUSTOMER: _____ ORDER#: _____

Main terminal diagram

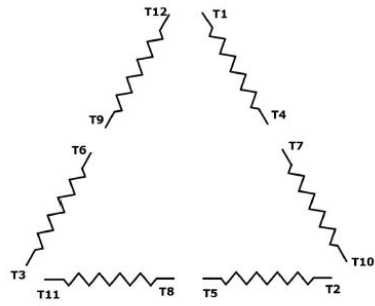

12 LEAD DELTA		
LINES	CONNECT TOGETHER	CONN.
L1	T12 - T7 - T6 - T1	ΔΔ
L2	T10 - T8 - T4 - T2	
L2	T11 - T9 - T5 - T3	

responsible dep. DI MC LVM	technical reference	created by	approved by	Project	
	document type Wiring Diagram		document status free		customer
	title 1PC6521-5FA71-2AA1		document number		
© Siemens AG 2019		rev. 01	creation date 12/03/2019	language en	Page 1/1