

NEMA MOUNTING HOLES
 DRILL THRU
 NEMA HOLE SIZE
 Ø21 (Ø13/16")
 12 PLACES

3'-8NPT DRILL&TAP
 3/8"-16 UNC GND BOLT
 BOTH SIDE

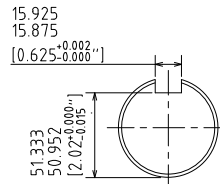

Scale:3.0

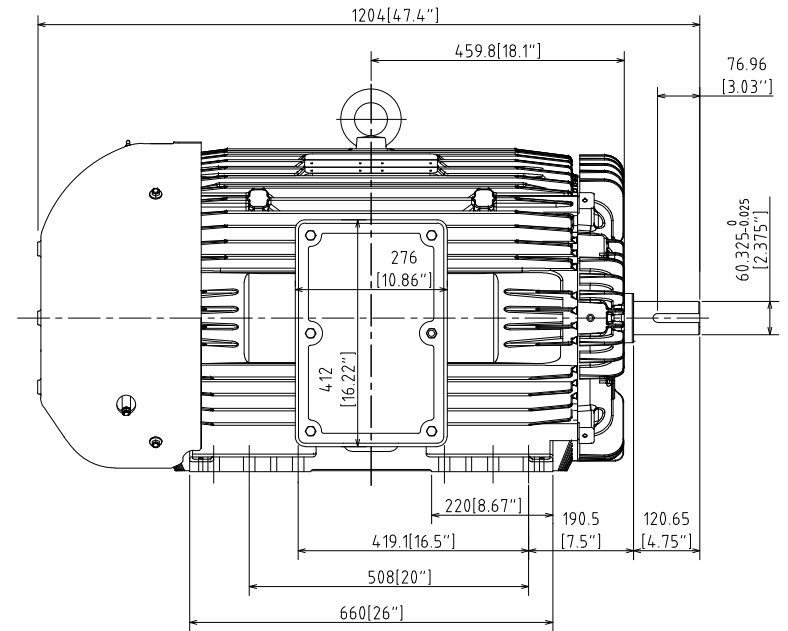

UNITS: INCHES

ROTATION FROM NDE

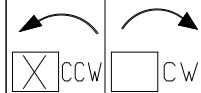

NOTES:

1. MAIN CONDUIT BOX MAY BE ROTATED IN 90° INCREMENTS
2. STANDARD PRODUCT USES BI-DIRECTIONAL FAN. OPPOSITE ROTATION AVAILABLE ONLY BY CONNECTION CHANGE.
3. KEY DIMENSIONS EQUAL 5/8"-5/8"-3" (MOTOR SUPPLIED WITH KEY)

TOSHIBA RESERVES THE RIGHT TO MAKE CHANGES OF TECHNICAL IMPROVEMENT AND THE DATA MAY CHANGE WITHOUT NOTICE PRELIMINARY

DO NOT USE FOR CONSTRUCTION, INSTALLATION, OR APPLICATION PURPOSES UNLESS THE DRAWING IS MARKED AS CERTIFIED CERTIFIED

TOSHIBA SEVERE DUTY
 www.toshiba.com/tic **EQP Global SD**
 TOSHIBA INTERNATIONAL CORPORATION

TOTALLY ENCLOSED FAN COOLED
 HORIZONTAL FOOT MOUNT
 3 PHASE INDUCTION MOTOR
 S445/7TS F1 ASSEMBLY

DRAWING #: MDSL V700-12
 REV. DATE: Nov-22-18 REV. #: PER: MAI HUYEN
 REV. DESCRIP: _____



Issued Date	10/21/2019	Transmit #	
Issued By	dschoeck	Issued Rev	

TYPICAL MOTOR PERFORMANCE DATA

Model: 2002SDSB41B-P

HP	kW	Pole	FL RPM	Frame	Voltage	Hz	Phase	FL Amps
200	150	2	3575	S447T	460	60	3	221
Enclosure	IP	Ins. Class	S.F.	Duty	NEMA Nom. Eff.	NEMA Design	kVA Code	Ambient (°C)
TEFC	54	F	1.15	CONT	95.4	B	F	40 C

Load	HP	kW	Amperes	Efficiency (%)	Power Factor (%)
Full Load	200	149.1	221.2	95.9	88.3
¾ Load	150.00	111.9	168.3	95.1	87.7
½ Load	100.00	74.6	117.8	93.3	85.1
¼ Load	50.00	37.3	72.1	87.7	74.0
No Load			53.5		7.2
Locked Rotor			1405		22.9

Torque				Rotor wk ² Inertia (lb-ft ²)
Full Load (lb-ft)	Locked Rotor (% FLT)	Pull Up (% FLT)	Break Down (% FLT)	
294	140	105	270	52.93

Safe Stall Time(s)		Sound Pressure dB(A) @ 1M	Bearings*		Approx. Motor Weight (lbs)
Cold	Hot		DE	NDE	
27	11	87	6313C3	6313C3	

*Bearings are the only recommended spare part(s).

Motor Options:
 Product Family:EQP Global SD
 Mounting:Footed,Shaft:T Shaft

Customer	
Customer PO	
Sales Order	
Project #	

Tag:

All characteristics are average expected values.

TOSHIBA INTERNATIONAL CORPORATION · HOUSTON, TEXAS U.S.A.

Engineering	mcampbell	Doc. Written By	D. Suarez	Doc.# / Rev	MPCF-1119 / 1
Engr. Date	11/8/2018	Doc. Approved By	M. Campbell	Doc. Issued	9/20/2019



Issued Date	10/21/2019	Transmit #	
Issued By	dschoeck	Issued Rev	

SPEED TORQUE/CURRENT CURVE

Model: 2002SDSB41B-P

HP	kW	Pole	FL RPM	Frame	Voltage	Hz	Phase	FL Amps
200	150	2	3575	S447T	460	60	3	221
Enclosure	IP	Ins. Class	S.F.	Duty	NEMA Nom. Eff.	NEMA Design	kVA Code	Ambient (°C)
TEFC	54	F	1.15	CONT	95.4	B	F	40 C
Locked Rotor Amps	Rotor wk ² Inertia (lb-ft ²)	Torque				Pull Up (%)	Break Down (%)	
		Full Load (lb-ft)	Locked Rotor (%)					
1405	52.93	294	140		105	270		

Design Values

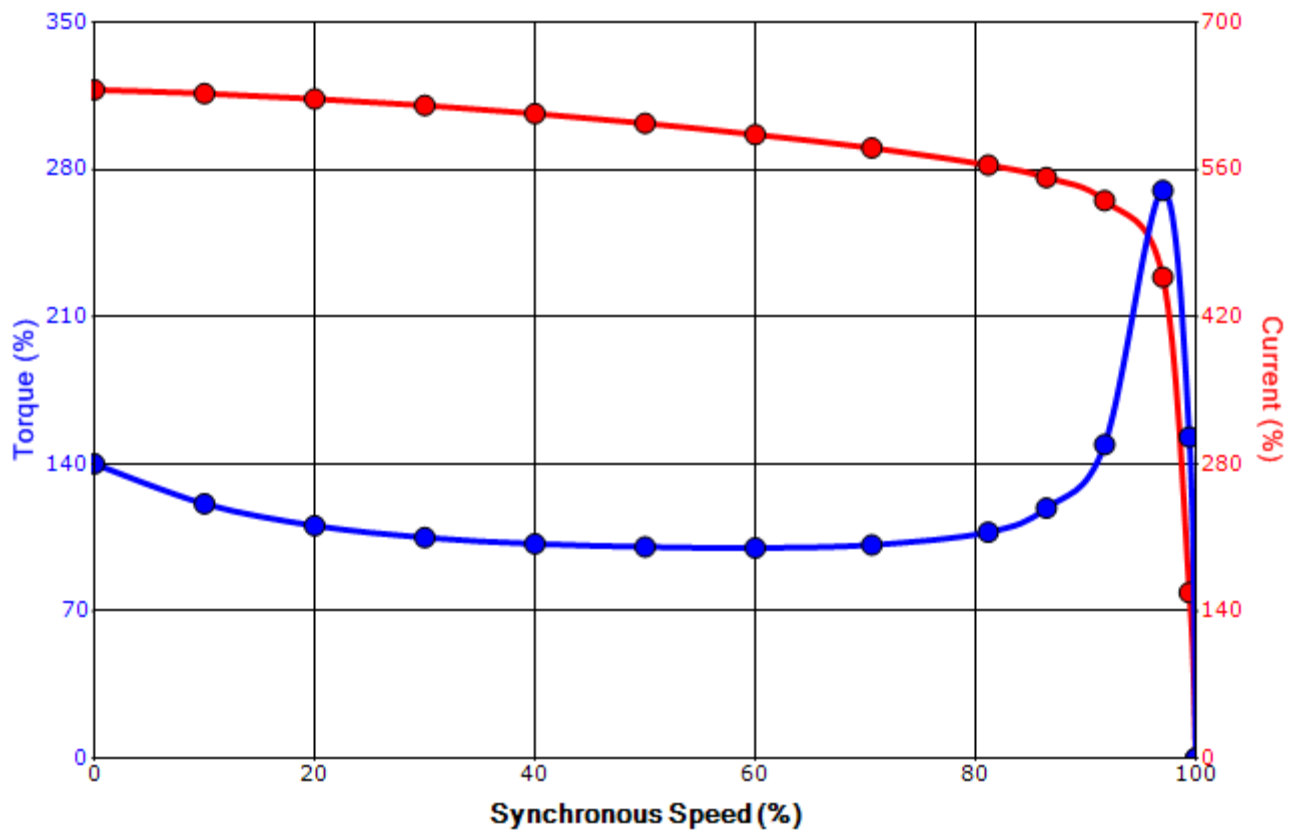

Customer		wk ² Load Inertia (lb-ft ²)	-
Customer PO		Load Type	-
Sales Order		Voltage (%)	100
Project #		Accel. Time	-

Tag:

All characteristics are average expected values.

TOSHIBA INTERNATIONAL CORPORATION · HOUSTON, TEXAS U.S.A.

Engineering	mcampbell	Doc. Written By	D. Suarez	Doc.# / Rev	MPCF-1121/1
Engr. Date	11/8/2018	Doc. Approved By	M. Campbell	Doc. Issued	9/20/2019

Motor Connection Diagram

12 Leads

Single Voltage



Switch L1 and L2 to reverse rotation