

BALDOR® • RELIANCE 

Product Information Packet

340

.25/.06HP,3600/1800RPM,1PH,60HZ,3424S

Part Detail							
Revision:	AV	Status:	PRD/A	Change #:		Proprietary:	No
Type:	AC	Elec. Spec:	L4WGW024	CD Diagram:	CD1491	Mfg Plant:	
Mech. Spec:	L34-24	Layout:	L4LY0024	Poles:	02/04	Created Date:	
Base:	RG	Eff. Date:	12-15-2021	Leads:	9#18		

Specs			
Nameplate Output:	.25/.06		
Product Style:	DENTAL LATHE		

Nameplate NP3351L

CAT.NO.	340		
SPEC.	L34-24W24		
HP	.25/.06		
VOLTS	115		
PHASE	1	AMPS	2.9/2
CYCLE	60		
RPM	3600/1800		
CL	B		
RATING	40C AMB-CONT		
SERIAL			

Parts List		
Part Number	Description	Quantity
SA005000	SA L34-24W24	1.000 EA
RA002350	RA L34-24W24	1.000 EA
L4BA1000A01	BASE, MACH	1.000 EA
19XX2510A10	1/4-10X5/8 HX HD PLASTITESCREW	2.000 EA
HW1001A25	LOCKWASHER 1/4, ZINC PLT .493 OD, .255 I	2.000 EA
SP9019SP	SWITCH 7563K6 (EATON)	1.000 EA
HW1003A50	LOCKWASHER,1/2",EXT.TOOTHZINC PLATED	1.000 EA
WD4000A07	SWITCH GUARD FOR DENTAL LATHE	1.000 EA
LD5001A07	CORD & PLUG ASSY 18-3 SJT .33 DIA. 10 AM	1.000 EA
WD4102A01	SR-6L-1 HEYCO STRN RELIEF OR 23MPO6L10 M	1.000 EA
L4CB4500	34 POLISHING LATHE	1.000 EA
51XW1032A06	10-32 X .38, TAPTITE II, HEX WSHR SLTD S	2.000 EA
RM1005A01SP	BUMPER- #2089 (R-R CO)	4.000 EA
11XW1032G06	10-32 X .38, TAPTITE II, HEX WSHR SLTD U	1.000 EA
L4EP3100A02	ENDPLATE, MACH LH	1.000 EA
HA6105A01	DR-178A L.H.EJECT.W/HANDL (WELKER)	1.000 EA
HA3100A29	THRUBOLT 10-32 X 7.00	4.000 EA
XY1032A02	10-32 HEX NUT DIRECTIONAL SERRATION	4.000 EA
HA1025A02	FELT WSH1.25OD/.87IDX.125 X	2.000 EA
L4EP3100A01	ENDPLATE, MACH	1.000 EA
HA6105A02	DR-178B R.H.EJECT.W/HANDL (WELKER)	1.000 EA
51XW0832A07	8-32 X .44, TAPTITE II, HEX WSHR SLTD SE	2.000 EA
MG2000A17	RUST INHIBITOR PART # SRPO #20	0.001 GA
51XW0832A07	8-32 X .44, TAPTITE II, HEX WSHR SLTD SE	2.000 EA

Parts List (continued)		
Part Number	Description	Quantity
MG1000G18	PAINT, 189-905 SILVER HAMR	0.013 GA
LB1208	WARNING LABEL FOR POLISHING LATHE MOTORS	1.000 EA
MN904	Baldor Polishing Lathes 6/05	1.000 EA
WD4006C05	ORANGE, WIRENUT, G-B #13-003 ORGSIZE 73B	5.000 EA
HW1000A25	1/4 SAE FLAT WASHER (FS)	2.000 EA
85XU0407S04	4X1/4 U DRIVE PIN STAINLESS	4.000 EA
SP5087A05	34/35 TORQ STAT SW W/BACK CONTACTS LEAD	1.000 EA
LB1119N	WARNING LABEL	1.000 EA
NP3351L	ALUM LATHE NO LOGOS	1.000 EA
27PA1001	PKG GRP, PRINT PK1027A06	1.000 EA
WD1000A27	2-520263-4 AMP TRM 3.4/RL	2.000 EA
HW3207A01	5 1/2" DENN. CABLE TIE (F/S)	1.000 EA
LB1618	PROPOSITION 65 WARNING LABEL 1-1/2 X 1/2	1.000 EA

Accessories		
Part Number	Description	Multiplier
R1	DR-3544 R1 RH CHUCK	A8
R2	DR-3546B R2 RH WHEEL CHUCK	A8
R5A	BURR CHUCK-RH	A8
R6	ARBOR BAND CHUCK	A8
L3	DR-3545 LH HD WHEEL CHUCK	A8
L4	DR-3547B L4 LH SF WHEEL CHUCK	A8

No performance data has been
assigned to this product.

L4LY0024

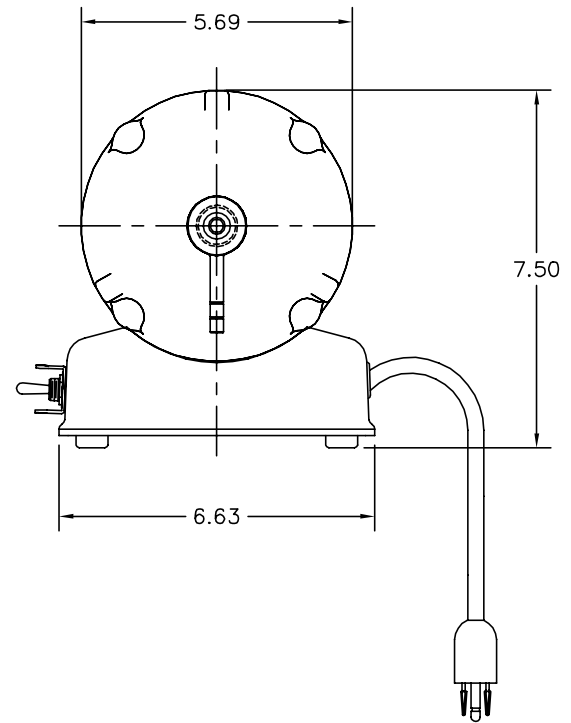
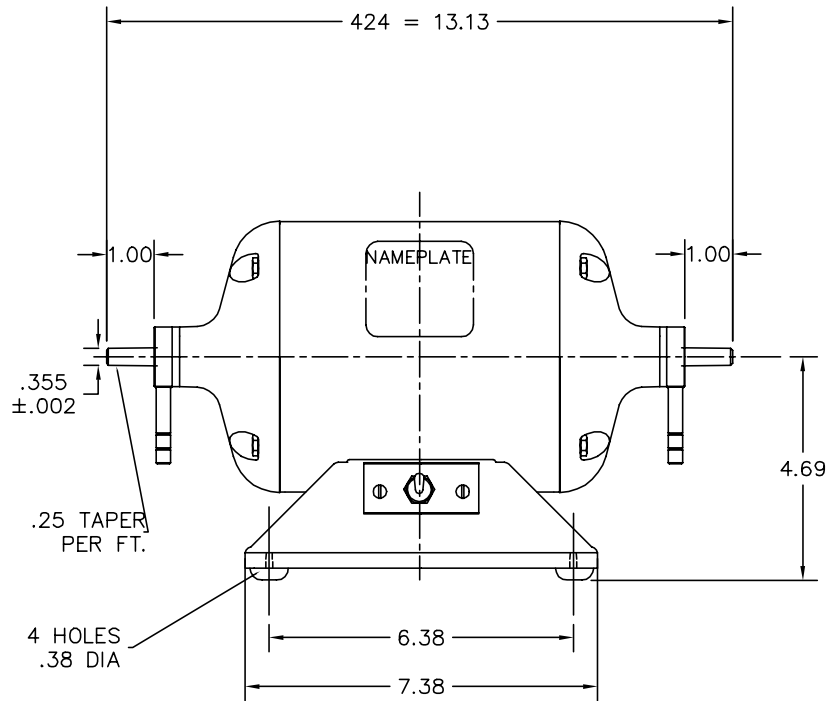

CUSTOMER IS RESPONSIBLE FOR DETERMINING THAT BALDOR'S PRODUCT WILL PERFORM SUITABLY IN THE INTENDED APPLICATION.

REV. DESC: REPLACE "DENTAL" WITH "POLISHING" TO DESCRIPTION		
REV. LTR: F	VERSION: 01	TDR: 000000826174
FILE: \AAA\00045\972	REVISED: 09:28:43 11/14/2013	BY: ENMAIYO
MTL: -		

BALDOR

SPL 34 POLISHING LATHE 115 VOLTS TENV 424S 2 SPEED

SH 1 of 1

L4LY0024

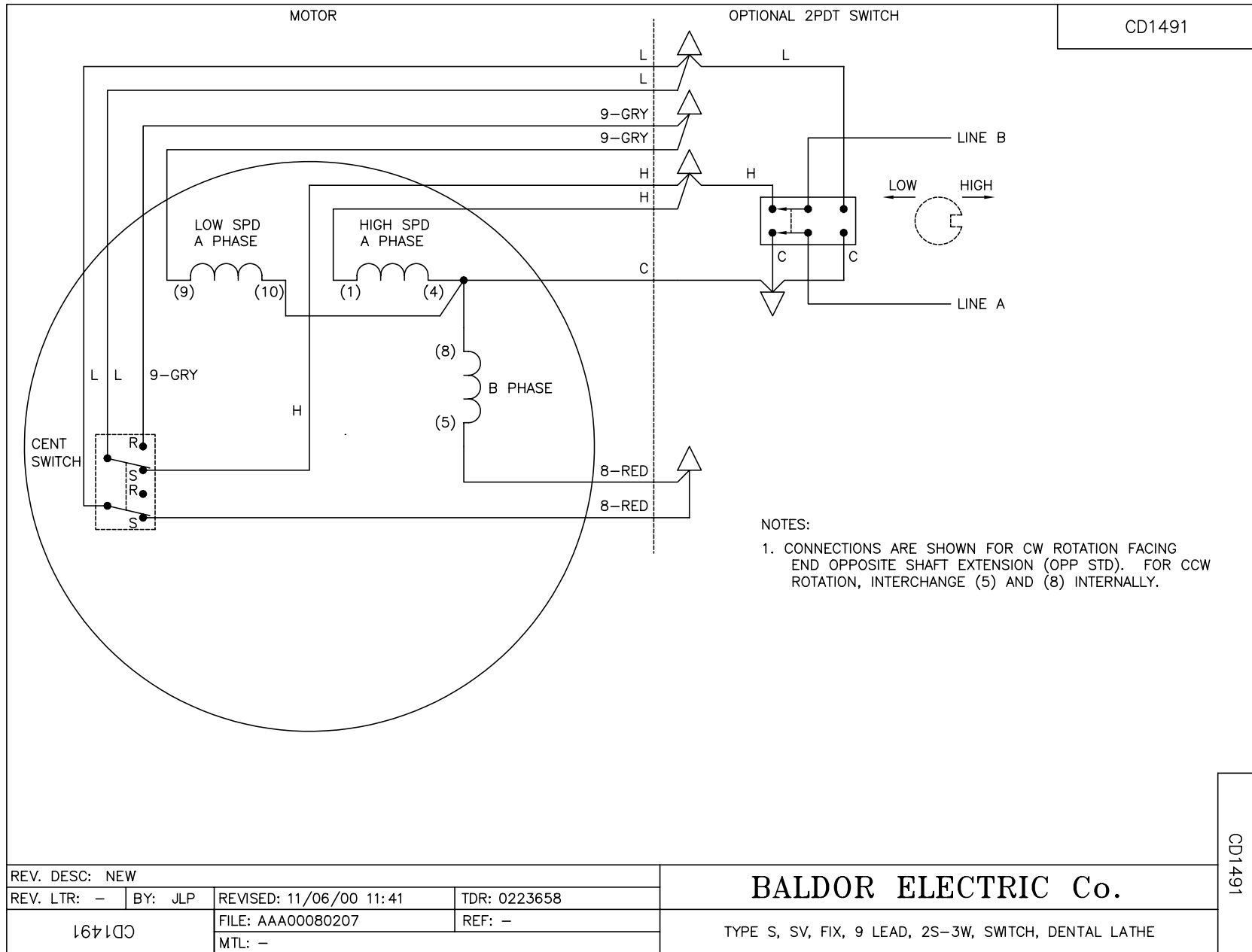

NOTES:
 1. CONNECTIONS ARE SHOWN FOR CW ROTATION FACING END OPPOSITE SHAFT EXTENSION (OPP STD). FOR CCW ROTATION, INTERCHANGE (5) AND (8) INTERNALLY.

REV. DESC: NEW			
REV. LTR: -	BY: JLP	REVISED: 11/06/00 11:41	TDR: 0223658
CD1491		FILE: AAA00080207	REF: -
		MTL: -	

BALDOR ELECTRIC Co.
 TYPE S, SV, FIX, 9 LEAD, 2S-3W, SWITCH, DENTAL LATHE

CD1491