

BALDOR® • RELIANCE 

Product Information Packet

500

.5HP,3600RPM,1PH,60HZ,3524C,3524C,TENV

Part Detail							
Revision:	BJ	Status:	PRD/A	Change #:		Proprietary:	No
Type:	AC	Elec. Spec:	G9WG0343	CD Diagram:	CD0285	Mfg Plant:	
Mech. Spec:	A-559	Layout:	ALY0559	Poles:	02	Created Date:	08-08-2007
Base:	RG	Eff. Date:	12-15-2021	Leads:	3#18		

Specs			
Nameplate Output:	.5		
Product Style:	GRINDER		

Nameplate NP3118	
CAT.NO.	500
HP	.5
PHASE	1
HZ	60
SER.NO	
SPEC.	A-559-343
	VOLTS 115
	AMPS 5
	RPM 3600

Parts List		
Part Number	Description	Quantity
SA037565	SA A-559-343	1.000 EA
RA033590	RA A-559-343	1.000 EA
OC3012F12SP	CYL OIL CAP 12MFD/370V	1.000 EA
G8BA3000A02	BASE, MACH	1.000 EA
19XX2510A14	1/4-10 X 7/8 HEX HD PLASTITE SCREW	4.000 EA
HW1001A25	LOCKWASHER 1/4, ZINC PLT .493 OD, .255 I	4.000 EA
HA6053A01ZP	CLAMP, CAPACITOR 2" DIA, WHITE ZINC PLAT	1.000 EA
51XN1032A04	10-32 X 0.25 HX WS SL SR	3.000 EA
XY1032A01	10/32 SQUARE NUT	3.000 EA
HW1001A10	WASHER, #10 SPLT LK, ZN X	3.000 EA
WD4102A04	SR 7P-2 HEYCO STRN RELIEF OR 22MP07P20 M	1.000 EA
LD5001A01	CORD & PLUG SET 18/3 SJTOW 105C 300V 8'	1.000 EA
WD4006A01	WIRE JOINT,T&B RB-4 OR RB-44	2.000 EA
11XW1032G06	10-32 X .38, TAPTITE II, HEX WSHR SLTD U	1.000 EA
HW1001A10	WASHER, #10 SPLT LK, ZN X	1.000 EA
SP9019SP	SWITCH 7563K6 (EATON)	1.000 EA
HW1003A50	LOCKWASHER,1/2",EXT.TOOTHZINC PLATED	1.000 EA
WD1000A02	41202 AMP RECP.(11M/REEL)NON-CANCELABLE/	4.000 EA
G8CB4500A02	G8-272 BASE COVER,STPD X PLATED	1.000 EA
51XW0832A07	8-32 X .44, TAPTITE II, HEX WSHR SLTD SE	4.000 EA
G9EP1900A02	ENDPLATE, MACH	1.000 EA
HW5100A04	WAVY WASHER, 204 BRG	1.000 EA
G9EP1900A03	ENDPLATE, MACH	1.000 EA
51XN1032A18	10-32 X 1 1/8 HX WS SL SR (ESKAY)	4.000 EA

Parts List (continued)		
Part Number	Description	Quantity
HA3100A45	THRUBOLT 10-32 X 8.875	4.000 EA
XY1032A02	10-32 HEX NUT DIRECTIONAL SERRATION	4.000 EA
G9FH1800A01	GRINDER GUARD, MACH	1.000 EA
HA3212A01	DR-1895D TABLE GUIDE PLMS(AUTO.MACH)	4.000 EA
10XN2520A14	1/4 20X7/8 HX HD CAP	4.000 EA
HW1001A25	LOCKWASHER 1/4, ZINC PLT .493 OD, .255 I	4.000 EA
G9FH1800A01	GRINDER GUARD, MACH	1.000 EA
HA3212A01	DR-1895D TABLE GUIDE PLMS(AUTO.MACH)	4.000 EA
10XN2520A14	1/4 20X7/8 HX HD CAP	4.000 EA
HW1001A25	LOCKWASHER 1/4, ZINC PLT .493 OD, .255 I	4.000 EA
G9AP1003A01	TABLE CLAMP, MACH AMB	4.000 EA
HA5001A01	HA5001A01 TABLE CL.SCREW WELKER	4.000 EA
HW1000A38	WASHER, 3/8" FLAT, SAE Z/P	4.000 EA
HW1001A38	LOCKWASHER 3/8, ZINC PLT .688 OD, .382 I	4.000 EA
G9AP1000A01	TABLE, TOOL GR, MACH	2.000 EA
G9AP1001A01	WATER TRAY, 153 CARBIDE TOOL GRINDER	2.000 EA
HA3405A01	DR-798A STUD(AUTO.MACH)	4.000 EA
G9AP1005A02	DR799B LH ANGLE INDICATOR ZINC PLATED	2.000 EA
51XN1032A06	10-32 X .38 HEX SLOTTED SERRATED WASHER	4.000 EA
HA3407A01	DR-780 TABLE STUD(AUTO)	2.000 EA
XY3118A12	5/16-18 HEX NUT DIRECTIONAL SERRATION	2.000 EA
G9AP1005A01	DR799A RH ANGLE INDICATOR PLATED	2.000 EA
51XN1032A06	10-32 X .38 HEX SLOTTED SERRATED WASHER	4.000 EA
HA3407A01	DR-780 TABLE STUD(AUTO)	2.000 EA

Product Information Packet: 500 - .5HP,3600RPM,1PH,60HZ,3524C,3524C,TENV

XY3118A12	5/16-18 HEX NUT DIRECTIONAL SERRATION	2.000 EA
G9AP5000A01SP	TOOL REST ASSEMBLY	1.000 EA
HA6104A01SP	WHEEL FLANGE, MACH	2.000 EA
HA3007A01SP	DR8218 SCREW (WELKER) AISI-1018	8.000 EA
HA3203A12	3/4-16HEX JAM NUT(RH)MACH	2.000 EA
G9AP1008A01	HUB PROTECTOR FOR GRINDER 3.88"OD	2.000 EA
G9AP1008A02	HUB PROTECTOR FOR GRINDER 4.425"OD	2.000 EA
RM1010A06	VNYL CAP 1.125-14 701-89 BLACK S/R Q=	2.000 EA
G9AP5001A01	WATER POT ASSEMBLY	1.000 EA
HA3406A01	DR-798B STUD (AUTO)	2.000 EA
G9AP1006A01SP	GRINDER LIGHT VIMCO	1.000 EA
51XB1016A08	10-16X 1/2HXWSSLD SERTYB	2.000 EA
HA1005A03SP	SLINGER, OD 1.750, ID .938, 205 BRG	2.000 EA
LB1008	LABEL, UL	1.000 EA
LB1618	PROPOSITION 65 WARNING LABEL 1-1/2 X 1/2	1.000 EA
LB1015	LABEL, UL APP CARBIDE GDR	1.000 EA
LB1034	LABEL, "ON" AND "OFF" X	1.000 EA
85XU0407A04	#4-7 X 1/4 DRIVE PIN	2.000 EA
MJ1000A02	GREASE, MOBIL POLYREX EM - 124047	0.050 LB
MG1000G01	MUNSELL 5.93PB 3.81/ 2.71	0.017 GA
WD1000A29	3-520140-4 AMP TRM=3.4M/R 16-14AWG	6.000 EA
NP3118	ALUM GRINDERS-BUFFERS NO LOGO'S	1.000 EA
LB1119N	WARNING LABEL	1.000 EA
07PA1007	PKG GRP, PRINT PK1156A06	1.000 EA
PK3088	MICROFOAM, 8"X"8 PERF. SHEETS	0.001 EA
PK1114	CARTON(OPF)GRINDER PARTS,13-1/4X8-1/4X2	2.000 EA

MN905	Inst. Manual for Tool Grinders 9/03	1.000 EA
-------	-------------------------------------	----------

Accessories		
Part Number	Description	Multiplier
GA16	PEDESTAL INDUSTRIAL, CAST IRON 6" - 10"	A8
GA14	PEDESTAL FABRICATED STEEL W/SHELVES	A8
GA20	PEDESTAL INDUSTRIAL, CAST IRON 8"-14"	A8
GA20E	PEDESTAL LIGHT INDUSTRIAL,STEEL	A8
GA7	DIAMOND NIB FOR GA8	A8
GA8	WHEEL DRESSER	A8
C61	60 GRIT CARBIDE GRINDING WHEEL	A8
C121	120 GRIT CARBIDE GRINDING WHEEL	A8
S46	46 GRIT GRINDING WHEEL/ALUM OXIDE	A8
S61	60 GRIT GRINDING WHEEL/ ALUM. OXIDE	A8
BQ1-015-CC	1PH Brake, NEMA 1,110-125 VAC, 50/60Hz	P1
BQ1-015-CP	1PH Brake, Panel 110-125 VAC, 50/60 Hz	P1

No performance data has been
assigned to this product.

ALY0559

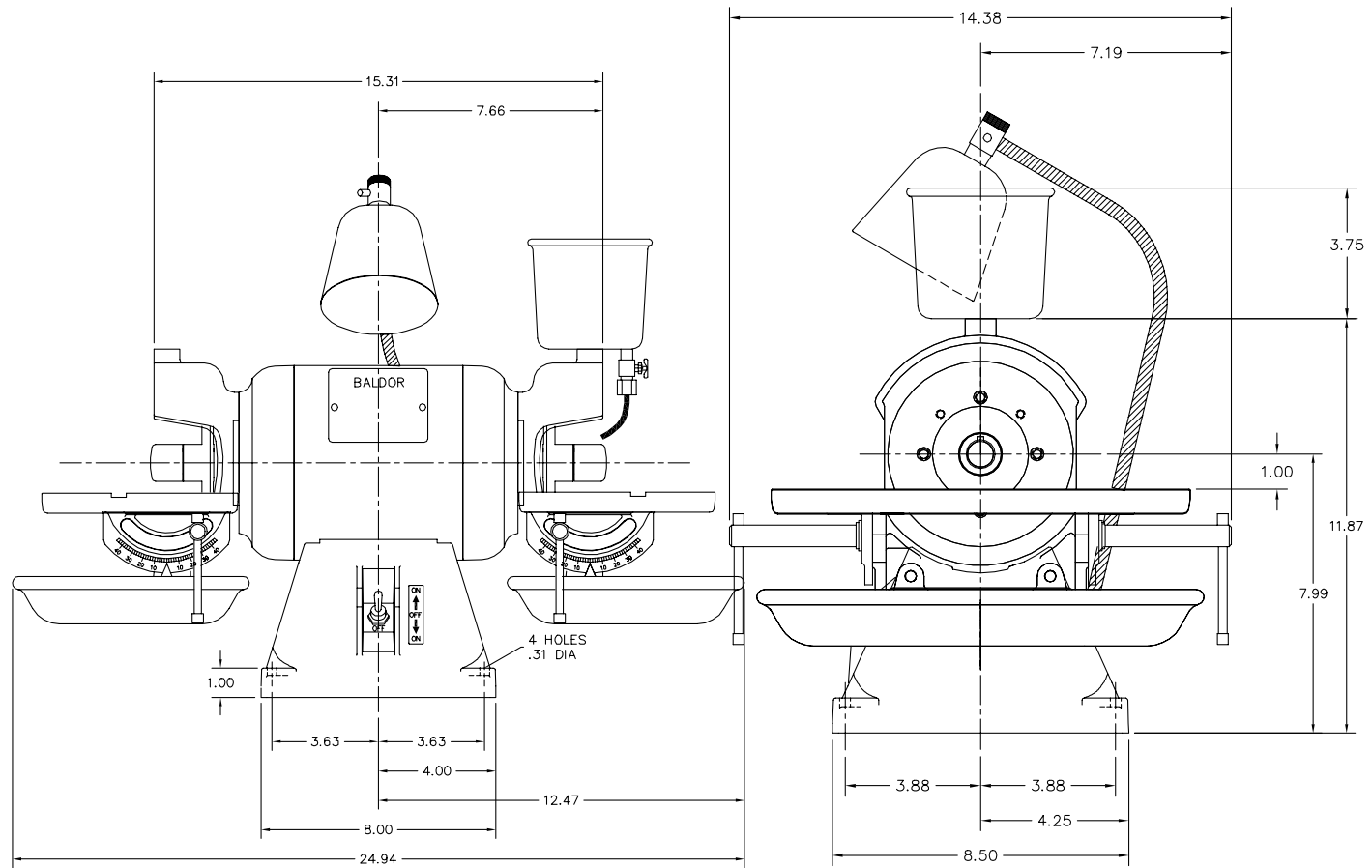

ALY0559

CUSTOMER IS RESPONSIBLE FOR DETERMINING THAT THE PRODUCT WILL PERFORM SUITABLY IN THE INTENDED APPLICATION.

REV. DESC: REMOVE RUBBER FEET	VERSION: 01	TDR: 000001183183
REV. LTR: E	REVISED: 01:03:29 12/17/2021	BY: USANEAT
FILE: \AAA\00050\586		
MTL: -		

BALDOR - RELIANCE[®]
 STD CARBIDE TOOL GRINDER MODEL 35 524C FRAME
 SH 1 of 1

