

BALDOR® • RELIANCE 

Product Information Packet

522

.5HP,3600RPM,1PH,60HZ,3524C,3524C,TENV

Part Detail							
Revision:	BF	Status:	PRD/A	Change #:		Proprietary:	No
Type:	AC	Elec. Spec:	G9WG0343	CD Diagram:	CD0285	Mfg Plant:	
Mech. Spec:	A-738	Layout:	ALY0738	Poles:	02	Created Date:	08-08-2007
Base:	RG	Eff. Date:	12-15-2021	Leads:	3#18 8.5" LG		Y

Specs			
Nameplate Output:	.5		
Product Style:	GRINDER		

Nameplate NP3118	
CAT.NO.	522
HP	.5
PHASE	1
HZ	60
SER.NO	
SPEC.	A-738-343
	VOLTS 115
	AMPS 5
	RPM 3600

Parts List		
Part Number	Description	Quantity
SA037569	SA A-738-343	1.000 EA
RA033594	RA A-738-343	1.000 EA
OC3012F12SP	CYL OIL CAP 12MFD/370V	1.000 EA
G8BA3000A02	BASE, MACH	1.000 EA
19XX2510A14	1/4-10 X 7/8 HEX HD PLASTITE SCREW	4.000 EA
HW1000A25	1/4 SAE FLAT WASHER (FS)	4.000 EA
HA6053A01ZP	CLAMP, CAPACITOR 2" DIA, WHITE ZINC PLAT	1.000 EA
51XN1032A04	10-32 X 0.25 HX WS SL SR	3.000 EA
XY1032A01	10/32 SQUARE NUT	3.000 EA
HW1001A10	WASHER, #10 SPLT LK, ZN X	3.000 EA
WD4102A04	SR 7P-2 HEYCO STRN RELIEF OR 22MP07P20 M	1.000 EA
LD5001A01	CORD & PLUG SET 18/3 SJTOW 105C 300V 8'	1.000 EA
WD4006A01	WIRE JOINT,T&B RB-4 OR RB-44	2.000 EA
11XW1032G06	10-32 X .38, TAPTITE II, HEX WSHR SLTD U	1.000 EA
HW1001A10	WASHER, #10 SPLT LK, ZN X	1.000 EA
SP9019SP	SWITCH 7563K6 (EATON)	1.000 EA
HW1003A50	LOCKWASHER,1/2",EXT.TOOTHZINC PLATED	1.000 EA
WD1000A02	41202 AMP RECP.(11M/REEL)NON-CANCELABLE/	4.000 EA
G8CB4500A02	G8-272 BASE COVER,STPD X PLATED	1.000 EA
51XW0832A07	8-32 X .44, TAPTITE II, HEX WSHR SLTD SE	4.000 EA
G9EP1900A02	ENDPLATE, MACH	1.000 EA
HW5100A04	WAVY WASHER, 204 BRG	1.000 EA
G9EP1900A10	R.H. ENDPLATE, MACH	1.000 EA
12XN1032A24	10-32 X 1 1/2 LG.HEX HEAD MACH. SLOTTED	4.000 EA

Parts List (continued)		
Part Number	Description	Quantity
HA3100A45	THRUBOLT 10-32 X 8.875	4.000 EA
HW1001A10	WASHER, #10 SPLT LK, ZN X	4.000 EA
XY1032A02	10-32 HEX NUT DIRECTIONAL SERRATION	4.000 EA
G9FH1800A01	GRINDER GUARD, MACH	1.000 EA
HA3212A01	DR-1895D TABLE GUIDE PLMS(AUTO.MACH)	4.000 EA
10XN2520A14	1/4 20X7/8 HX HD CAP	4.000 EA
HW1001A25	LOCKWASHER 1/4, ZINC PLT .493 OD, .255 I	4.000 EA
G9FH1800A01	GRINDER GUARD, MACH	1.000 EA
HA3212A01	DR-1895D TABLE GUIDE PLMS(AUTO.MACH)	4.000 EA
10XN2520A14	1/4 20X7/8 HX HD CAP	4.000 EA
HW1001A25	LOCKWASHER 1/4, ZINC PLT .493 OD, .255 I	4.000 EA
G9AP1003A01	TABLE CLAMP, MACH AMB	4.000 EA
HA5001A01	HA5001A01 TABLE CL.SCREW WELKER	4.000 EA
HW1000A38	WASHER, 3/8" FLAT, SAE Z/P	4.000 EA
HW1001A38	LOCKWASHER 3/8, ZINC PLT .688 OD, .382 I	4.000 EA
G9AP1000A01	TABLE, TOOL GR, MACH	2.000 EA
G9AP1001A01	WATER TRAY, 153 CARBIDE TOOL GRINDER	2.000 EA
HA3405A01	DR-798A STUD(AUTO.MACH)	4.000 EA
G9AP1005A02	DR799B LH ANGLE INDICATOR ZINC PLATED	2.000 EA
51XN1032A06	10-32 X .38 HEX SLOTTED SERRATED WASHER	4.000 EA
HA3407A01	DR-780 TABLE STUD(AUTO)	2.000 EA
XY3118A12	5/16-18 HEX NUT DIRECTIONAL SERRATION	2.000 EA
G9AP1005A01	DR799A RH ANGLE INDICATOR PLATED	2.000 EA
51XN1032A06	10-32 X .38 HEX SLOTTED SERRATED WASHER	4.000 EA

Product Information Packet: 522 - .5HP,3600RPM,1PH,60HZ,3524C,3524C,TENV

HA3407A01	DR-780 TABLE STUD(AUTO)	2.000 EA
XY3118A12	5/16-18 HEX NUT DIRECTIONAL SERRATION	2.000 EA
G9AP5000A01SP	TOOL REST ASSEMBLY	1.000 EA
HA6104A01SP	WHEEL FLANGE, MACH	2.000 EA
HA3007A01SP	DR8218 SCREW (WELKER) AISI-1018	8.000 EA
HA3203A12	3/4-16HEX JAM NUT(RH)MACH	2.000 EA
G9AP1008A01	HUB PROTECTOR FOR GRINDER 3.88"OD	2.000 EA
G9AP1008A02	HUB PROTECTOR FOR GRINDER 4.425"OD	2.000 EA
XY7516A13	3/4-16 NUT HEX JAM	2.000 EA
RM1010A06	VNYL CAP 1.125-14 701-89 BLACK S/R Q=	2.000 EA
G9AP5001A01	WATER POT ASSEMBLY	1.000 EA
HA3406A01	DR-798B STUD (AUTO)	2.000 EA
G9AP1006A01SP	GRINDER LIGHT VIMCO	1.000 EA
51XB1016A06	10-16X3/8 HXWSSLD SERTYB	2.000 EA
HA1005A03SP	SLINGER, OD 1.750, ID .938, 205 BRG	2.000 EA
LB1008	LABEL, UL	1.000 EA
LB1618	PROPOSITION 65 WARNING LABEL 1-1/2 X 1/2	1.000 EA
LB1015	LABEL, UL APP CARBIDE GDR	1.000 EA
LB1034	LABEL, "ON" AND "OFF" X	1.000 EA
85XU0407A02	4 X 1/8 DRIVE PIN	2.000 EA
MJ1000A02	GREASE, MOBIL POLYREX EM - 124047	0.050 LB
MG1000G01	MUNSELL 5.93PB 3.81/ 2.71	0.017 GA
NP3118	ALUM GRINDERS-BUFFERS NO LOGO'S	1.000 EA
07PA1007	PKG GRP, PRINT PK1156A06	1.000 EA
PK1114	CARTON(OPF)GRINDER PARTS,13-1/4X8-1/4X2	2.000 EA
PK3088	MICROFOAM, 8"X"8 PERF. SHEETS	0.001 EA

LB1119N	WARNING LABEL	1.000 EA
MN905	Inst. Manual for Tool Grinders 9/03	1.000 EA

Accessories		
Part Number	Description	Multiplier
GA16	PEDESTAL INDUSTRIAL, CAST IRON 6" - 10"	A8
GA14	PEDESTAL FABRICATED STEEL W/SHELVES	A8
GA20	PEDESTAL INDUSTRIAL, CAST IRON 8"-14"	A8
GA20E	PEDESTAL LIGHT INDUSTRIAL,STEEL	A8
D501	GENERAL PURPOSE DIAMOND WHEEL	A8
D502	FINE FINISH DIAMOND WHEEL	A8
BQ1-015-CC	1PH Brake, NEMA 1,110-125 VAC, 50/60Hz	P1
BQ1-015-CP	1PH Brake, Panel 110-125 VAC, 50/60 Hz	P1

No performance data has been
assigned to this product.

ALY0738

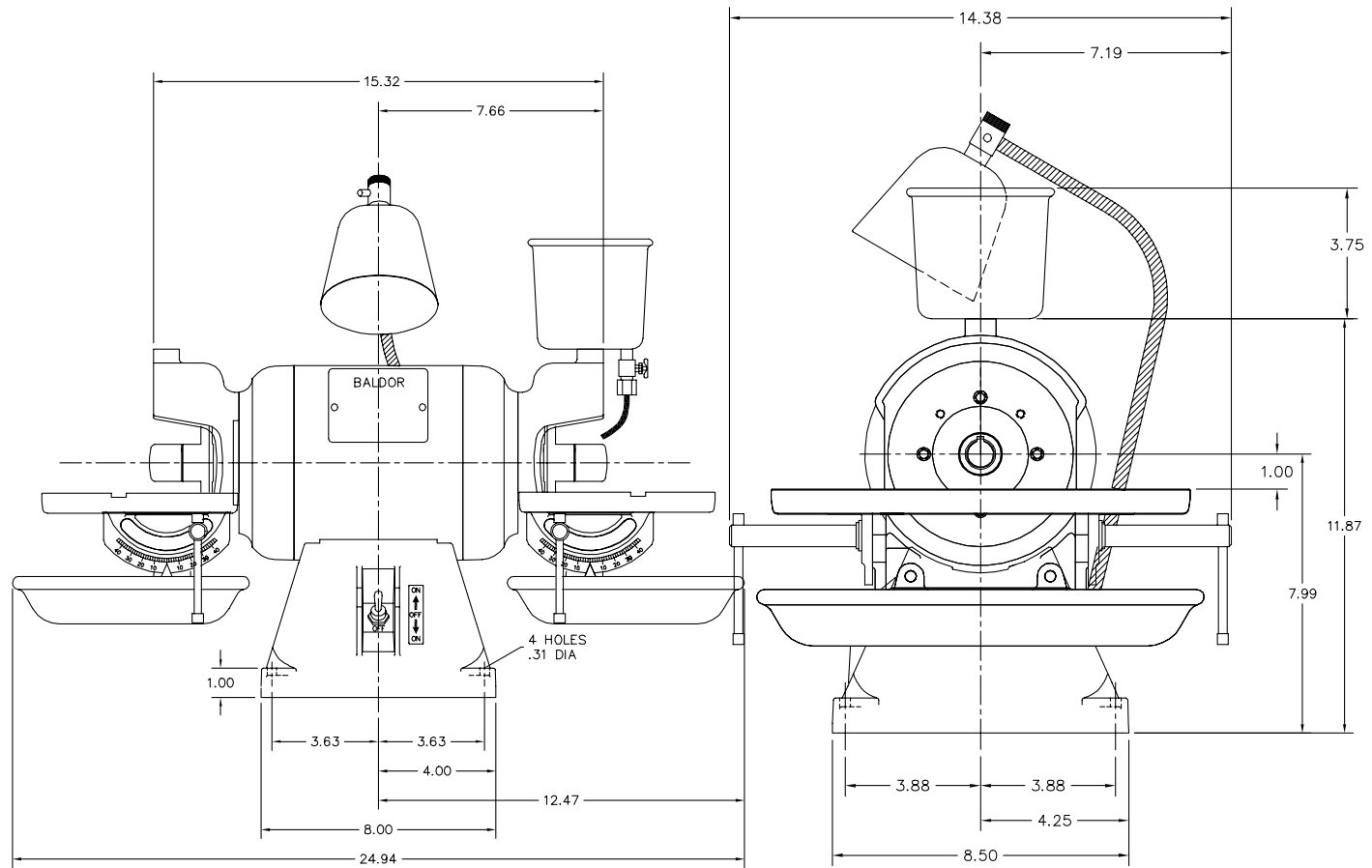

ALY0738

CUSTOMER IS RESPONSIBLE FOR DETERMINING THAT THE PRODUCT WILL PERFORM SUITABLY IN THE INTENDED APPLICATION.

REV. DESC: REMOVE RUBBER FEET	VERSION: 01	TDR: 000001183183
REV. LTR: M	REVISED: 01:15:34 12/17/2021	BY: USANEAT
FILE: \AAA\00050\728		
MTL: DIE CAST ALUM. - 380 ALLOY		

BALDOR - RELIANCE[®]
 STD DIAMOND WHEEL TOOL GRINDER 35 524C FRAME
 SH 1 of 1

