

3/8"-16 UNC
BOTH SIDES

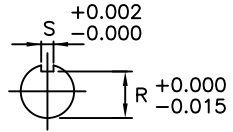
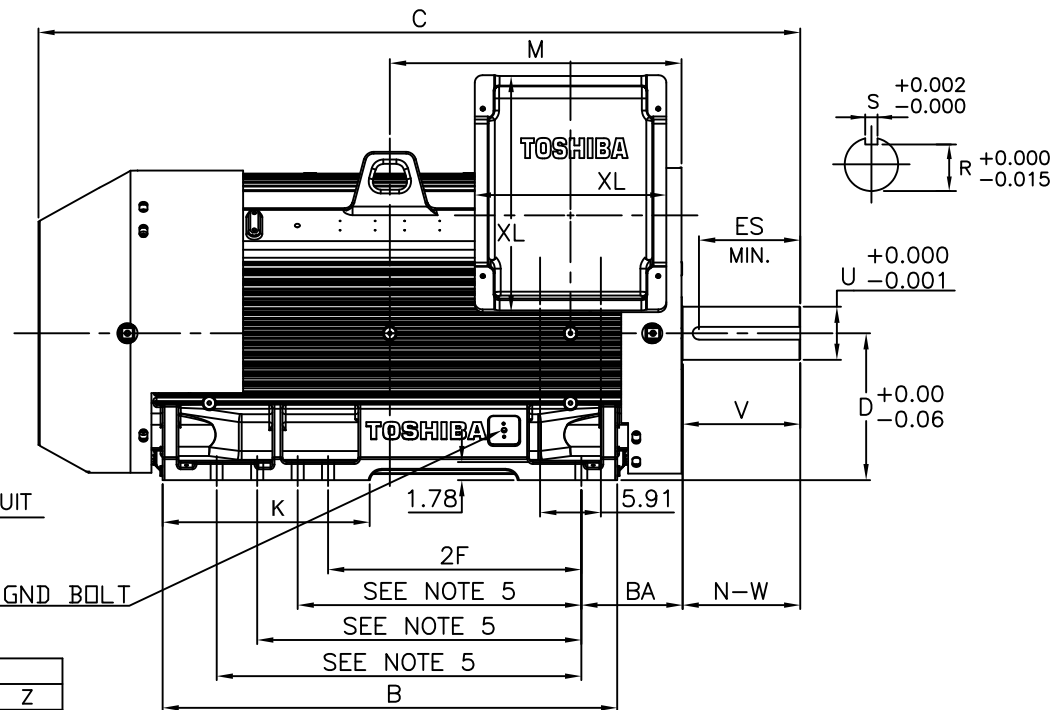
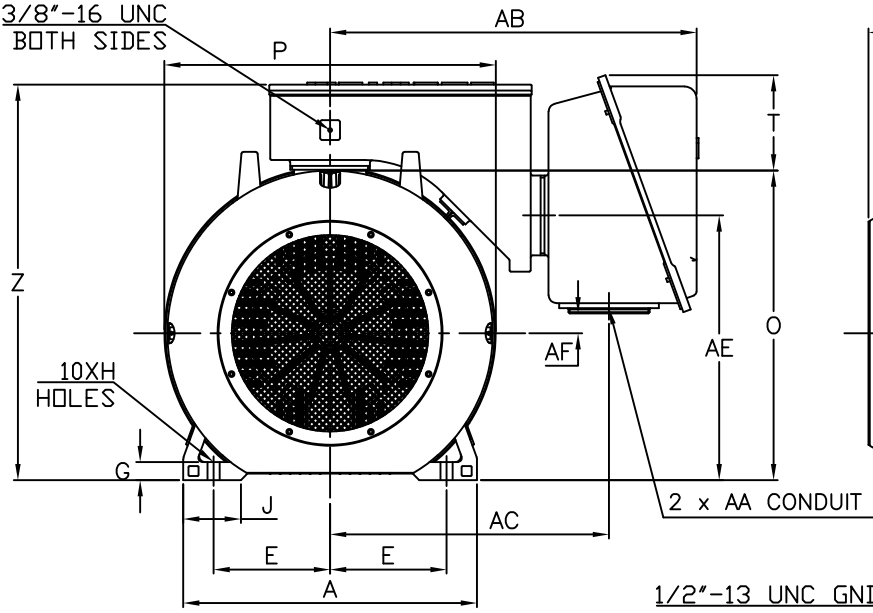

UNITS: INCHES

FRAME SIZE	MOTOR DIMENSIONS												
	A	B	C	D	G	J	K	M	O	P	T	Z	
B587/8/9/10LL	29.0	45.0	75.2	14.5	1.78	5.7	20.4	28.8	30.6	32.7	9.3	39.2	
B587/8/9/10LQ	29.0	45.0	75.2	14.5	1.78	5.7	20.4	28.8	30.6	32.7	9.3	39.2	
B587/8/9/10LS	29.0	45.0	71.8	14.5	1.78	5.7	20.4	28.8	30.6	32.7	9.3	39.2	

FRAME SIZE	CONDUIT BOX							
	AA[NPT]	AB	AC	AE	AF	XL	XN	
B587/8/9/10LL/LQ/LS	3.00	36.2	27.5	26.1	1.97	23.5	18.9	

FRAME SIZE	MOUNTING				SHAFT EXTENSION			KEY SEAT			BEARINGS			MAXIMUM WEIGHT
	E	2F	H	BA	N-W	V	U	R	S	ES	LS ROLLER	LS BALL	OS BALL	
B587/8/9/10LL	11.5	25.0/28.0/32.0/36.0	1.19	10.0	11.625	11.56	5.25	4.550	1.00	10.00	NU328C3	6328C3	6320C3	8000 lbs.
B587/8/9/10LQ	11.5	25.0/28.0/32.0/36.0	1.19	10.0	11.625	11.56	4.375	3.817	1.00	10.00	NU324C3	6324C3	6320C3	8000 lbs.
B587/8/9/10LS	11.5	25.0/28.0/32.0/36.0	1.19	10.0	8.25	8.19	3.875	3.309	1.00	6.30	NU322C3	6322C3	6320C3	8000 lbs.

- NOTES:
- DIMENSION V REPRESENTS LENGTH OF STRAIGHT PART OF SHAFT.
 - MAIN CONDUIT BOX MAY BE ROTATED IN 90° INCREMENTS.
 - "LL" KEY DIMENSIONS EQUAL S x S x 10.00
"LQ" KEY DIMENSIONS EQUAL S x S x 10.00
"LS" KEY DIMENSIONS EQUAL S x S x 6.30
(MOTOR SUPPLIED WITH KEY)
 - MOTOR WEIGHT SHOWN IS MAXIMUM HORSEPOWER IN FRAME.
 - THIS DIMENSION EQUALS 2F FOR 587/8/9/10 MOUNTING.
 - STANDARD PRODUCT USE BI-DIRECTIONAL FAN. OPPOSITE ROTATION AVAILABLE ONLY BY CONNECTION CHANGE.
 - FRAME GROUND BOLT STANDARD.

CUSTOMER: _____ MOTOR MODEL NO.: _____

P.O. NO.: _____ HP: _____ VOLTAGE: _____ RPM(SYN.): _____ Hz: _____

FRAME SIZE: _____ PRODUCT TYPE: TEFC PREMIUM EFFICIENCY QUARRY DUTY

COMMENTS: _____

PER: _____ DATE: _____

TAG NO's: _____

- STANDARD (NO AUX. BOXES)
- RTD AUX. BOX
- SPACE HEATER AUX. BOX
- BEARING RTD's

TOSHIBA RESERVES THE RIGHT TO MAKE CHANGES OF TECHNICAL IMPROVEMENT AND THE DATA MAY CHANGE WITHOUT NOTICE PRELIMINARY

DO NOT USE FOR CONSTRUCTION, INSTALLATION, OR APPLICATION PURPOSES UNLESS THE DRAWING IS MARKED AS CERTIFIED CERTIFIED

TOSHIBA
TOSHIBA INTERNATIONAL CORPORATION

TOTALLY-ENCLOSED FAN-COOLED
HORIZONTAL FOOT-MOUNTED
3 PHASE INDUCTION MOTOR
F1 ASSEMBLY

XT SERIES
VISIT OUR WEBSITE AT:
www.toshiba.com/ind

TYPICAL MOTOR PERFORMANCE DATA

Model: 7004QDSB31A-R

HP	kW	Pole	FL RPM	Frame	Voltage	Hz	Phase	FL Amps
700	522	4	1790	B587LL	460	60	3	829
Enclosure	IP	Ins. Class	S.F.	Duty	NEMA Nom. Eff.	NEMA Design	kVA Code	Ambient (°C)
TEFC	54	F	1.15	CONT	96.2	-		40 C

Load	HP	kW	Amperes	Efficiency (%)	Power Factor (%)
Full Load	700.00	522.0	829	96.1	82.2
¾ Load	525.00	391.5	644	95.5	79.9
½ Load	350.00	261.0	472	94.1	73.6
¼ Load	175.00	130.5	330	89.7	55.3
No Load			274.4		3.3
Locked Rotor			6014		26.8

Torque				Rotor wk ² Inertia (lb-ft ²)
Full Load (lb-ft)	Locked Rotor (% FLT)	Pull Up (% FLT)	Break Down (% FLT)	
2055	215	175	335	378.47

Safe Stall Time(s)		Sound Pressure dB(A) @ 1M	Bearings*		Approx. Motor Weight (lbs)
Cold	Hot		DE	NDE	
20	12	85	NU328C3	6320C3	

*Bearings are the only recommended spare part(s).

Motor Options:
Product Family:Quarry
Mounting:Footed,Shaft:LL IEC Frame
Motor Specification:Quarry Duty

Customer	
Customer PO	
Sales Order	
Project #	

Tag:

All characteristics are average expected values.

TOSHIBA INTERNATIONAL CORPORATION · HOUSTON, TEXAS U.S.A.

Engineering	SSuryani	Doc. Written By	D. Suarez	Doc.# / Rev	MPCF-1119 / 0
Engr. Date	6/16/2020	Doc. Approved By	M. Campbell	Doc. Issued	6/8/2011

SPEED TORQUE/CURRENT CURVE

Model: 7004QDSB31A-R

HP	kW	Pole	FL RPM	Frame	Voltage	Hz	Phase	FL Amps
700	522	4	1790	B587LL	460	60	3	829
Enclosure	IP	Ins. Class	S.F.	Duty	NEMA Nom. Eff.	NEMA Design	kVA Code	Ambient (°C)
TEFC	54	F	1.15	CONT	96.2	-		40 C
Locked Rotor Amps	Rotor wk ² Inertia (lb-ft ²)	Torque						Break Down (%)
		Full Load (lb-ft)	Locked Rotor (%)	Pull Up (%)				
6014	378.47	2055	215	175			335	

Design Values

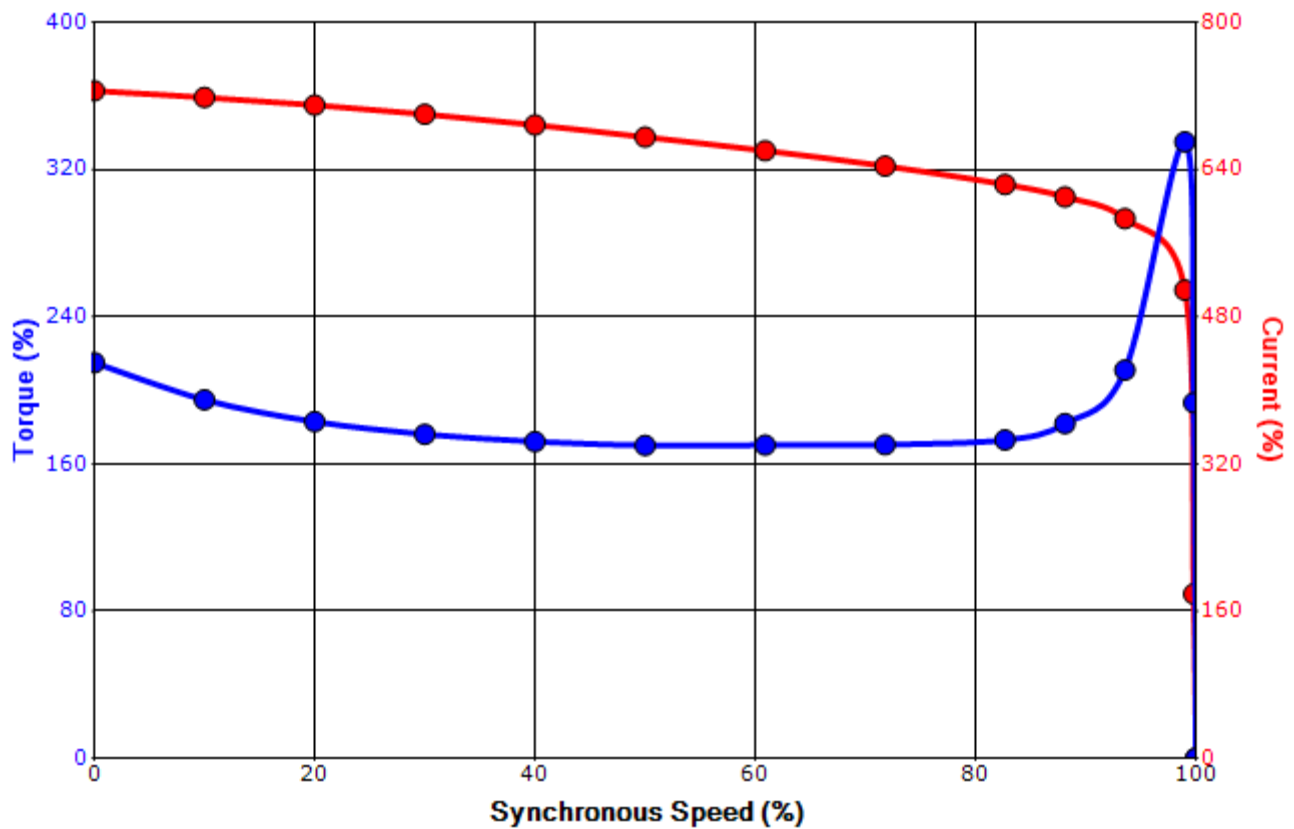

Customer		wk ² Load Inertia (lb-ft ²)	-
Customer PO		Load Type	-
Sales Order		Voltage (%)	100
Project #		Accel. Time	-

Tag:

All characteristics are average expected values.

TOSHIBA INTERNATIONAL CORPORATION · HOUSTON, TEXAS U.S.A.

Engineering	SSuryani	Doc. Written By	D. Suarez	Doc.# / Rev	MPCF-1121 / 0
Engr. Date	6/16/2020	Doc. Approved By	M. Campbell	Doc. Issued	6/8/2011

Motor Connection Diagram 3 Leads - Delta Connection



Switch L1 and L2 to reverse rotation

Each lead may consist of more than one cable.
If multiple cables represent a single lead, each one
of them will be labeled with the appropriate lead number.