

BALDOR® • RELIANCE 

Product Information Packet

712

.5HP,3600RPM,1PH,60HZ,3420C,GRND

Part Detail							
Revision:	BA	Status:	PRD/A	Change #:		Proprietary:	No
Type:	AC	Elec. Spec:	G7WG0030	CD Diagram:	CD0279	Mfg Plant:	
Mech. Spec:	G7-370	Layout:	G7LY0370	Poles:	02	Created Date:	
Base:	RG	Eff. Date:	12-15-2021	Leads:	4#18		

Specs			
Nameplate Output:	.5		
Product Style:	GRINDER		

Nameplate NP0113	
CAT.NO.	712
HP	.5
PHASE	1
HZ	60
SER.NO	
SPEC.	G7-370-30
	VOLTS 115
	AMPS 3.4
	RPM 3600

Parts List		
Part Number	Description	Quantity
SA004996	SA G7-370-30	1.000 EA
RA002346	RA G7-370-30	1.000 EA
OC3006F12	CYL OIL CAP 6MFD/370V	1.000 EA
G7BA3000	G7-286 BASE DIE CAST	1.000 EA
WD4102A01	SR-6L-1 HEYCO STRN RELIEF OR 23MPO6L10 M	1.000 EA
LD5001A07	CORD & PLUG ASSY 18-3 SJT .33 DIA. 10 AM	1.000 EA
WD1000A16	2-520128-2 AMP FLAG TERMINAL(4M/RL)	2.000 EA
SP9000SP	80600BJ A-H OR 1520237-2 TYCO;2PST,125/2	1.000 EA
HW1003A50	LOCKWASHER,1/2",EXT.TOOTHZINC PLATED	1.000 EA
HA3205A50	U550-N SWITCH NUT/CARLING	1.000 EA
WD1000A16	2-520128-2 AMP FLAG TERMINAL(4M/RL)	2.000 EA
G7CB4500	BASE COVER PLATE 7" GRINDER	1.000 EA
51XW1032A06	10-32 X .38, TAPTITE II, HEX WSHR SLTD S	2.000 EA
RM1005A01SP	BUMPER- #2089 (R-R CO)	4.000 EA
15XF1032A10	10-32X5/8 PIN HD PHL TY FSEE JT	4.000 EA
11XW1032G06	10-32 X .38, TAPTITE II, HEX WSHR SLTD U	1.000 EA
HA6053A01ZP	CLAMP, CAPACITOR 2" DIA, WHITE ZINC PLAT	1.000 EA
51XN1032A06	10-32 X .38 HEX SLOTTED SERRATED WASHER	2.000 EA
XY1032A02	10-32 HEX NUT DIRECTIONAL SERRATION	2.000 EA
G7EP3900A01	ENDPLATE, MACH	1.000 EA
HW5100A03	WAVY WASHER (W1543-017)	1.000 EA
HW5100A03	WAVY WASHER (W1543-017)	1.000 EA
G7EP3900A01	ENDPLATE, MACH	1.000 EA
HA3100A29	THRUBOLT 10-32 X 7.00	4.000 EA

Parts List (continued)		
Part Number	Description	Quantity
XY1032A02	10-32 HEX NUT DIRECTIONAL SERRATION	4.000 EA
G7FH3800A01SP	GRINDER GUARD, MACH	1.000 EA
G7FH3801SP	GRINDER GUARD COVER, CAST	1.000 EA
10XF2520A16	SCREW, HEX HD, ZN X	3.000 EA
51XF1032A10	SCREW, HX WS HD SER, ZN	3.000 EA
51XF1032A10	SCREW, HX WS HD SER, ZN	3.000 EA
G7FH3800A01SP	GRINDER GUARD, MACH	1.000 EA
G7FH3801SP	GRINDER GUARD COVER, CAST	1.000 EA
10XF2520A16	SCREW, HEX HD, ZN X	3.000 EA
HA6096A01SP	WHEEL FLANGE, MACH	2.000 EA
HA6096A01SP	WHEEL FLANGE, MACH	2.000 EA
HA2072	SPACER,WHEEL FLG(AUTO)	1.000 EA
HA2072	SPACER,WHEEL FLG(AUTO)	1.000 EA
HW3021C04	SPRG PIN 3/32 DIA .375LGH DRIV-LOK	1.000 EA
HW3021C04	SPRG PIN 3/32 DIA .375LGH DRIV-LOK	1.000 EA
G7AP3000A02	WHEEL, 7 X 1 X 60 GRIT B74 X	1.000 EA
G7AP3000A01	WHEEL, 7 X 1 X 36 GRIT B73 X	1.000 EA
XY6311A12SP	HEX NUT 5/8-11	1.000 EA
XY6311A62	5/8-11 NUT L.H. HEX (NC)X (F/S)	1.000 EA
G7AP5010A01	7" TOOL REST ASSEMBLY L.H.10 45819107	1.000 EA
10XN2520A08	1/4-20X1/2 HEX HEAD CAP	1.000 EA
HW1001A25	LOCKWASHER 1/4, ZINC PLT .493 OD, .255 I	1.000 EA
HW1000A25	1/4 SAE FLAT WASHER (FS)	1.000 EA
HW1001A25	LOCKWASHER 1/4, ZINC PLT .493 OD, .255 I	1.000 EA

Product Information Packet: 712 - .5HP,3600RPM,1PH,60HZ,3420C,GRND

HW1000A25	1/4 SAE FLAT WASHER (FS)	1.000 EA
G7AP5010A02	7" TOOL REST ASSEMBLY R.H.10 45818107	1.000 EA
10XN2520A08	1/4-20X1/2 HEX HEAD CAP	1.000 EA
G6AP1003A01	CHIP BREAKER 6" GRINDER PLATED	1.000 EA
G6AP1003A01	CHIP BREAKER 6" GRINDER PLATED	1.000 EA
HW1000A10	#10 FLAT WASHER (SAE)	1.000 EA
HW1000A10	#10 FLAT WASHER (SAE)	1.000 EA
G6AP5001A01A	EYESHIELD ASSY GA10 .35 50046107	1.000 EA
HA6093A01	SUPPORT ARM, EYESHIELD FOR 6" GRINDER PL	2.000 EA
HA6094A01SP	CLAMP FOR SUPPORT ARM X PLATED	2.000 EA
10XN2520A14	1/4 20X7/8 HX HD CAP	2.000 EA
HW1001A25	LOCKWASHER 1/4, ZINC PLT .493 OD, .255 I	2.000 EA
XY2520A12	1/4-20 HEX NUT, DIRECTIONAL SERRATIONS	2.000 EA
MG1000G01	MUNSELL 5.93PB 3.81/ 2.71	0.014 GA
85XU0407S04	4X1/4 U DRIVE PIN STAINLESS	2.000 EA
MN909	EYESHIELD MTG INSTR. FOR GA9, GA10 & GA1	1.000 EA
WD4006B01	TYPE O/B+ 3M SCOTCHLOK WIRE CONNECTOR	2.000 EA
LC0279A01	1PH, DV, FIX, GRINDER, CONN FOR LV	1.000 EA
NP0113	N.P.- DELUXE GRINDERS - BUFFERS	1.000 EA
LB1008	LABEL, UL	1.000 EA
LB1009N	LABEL,ROTATION DIRECTION (ON ROLLS)	1.000 EA
LB1030	LABEL, OSHA (ON ROLLS)	1.000 EA
LB1119N	WARNING LABEL	1.000 EA
LB1307	LABEL, WARNING	1.000 EA
35PA1007	PKG GRP, PRINT PK1034A06	1.000 EA
MN903	INSTR MANUAL FOR GRINDERS 9/03	1.000 EA

LB1618	PROPOSITION 65 WARNING LABEL 1-1/2 X 1/2	1.000 EA
--------	--	----------

Accessories		
Part Number	Description	Multiplier
GA16E	PEDESTAL LIGHT INDUSTRIAL,STEEL	A8
GA16	PEDESTAL INDUSTRIAL, CAST IRON 6" - 10"	A8
GA14	PEDESTAL FABRICATED STEEL W/SHELVES	A8
B73	7" 36 GRIT GRINDING WHEEL	A8
B74	7" 60 GRIT GRINDING WHEEL	A8
GA9	PAIR LIGHTED EYESHIELDS	A8
GA9-1	SINGLE LIGHTED EYESHIELD	A8
GA9S	PAIR EYESHIELDS W/ ON-OFF SWITCH	A8
GA11	PAIR EYESHIELDS	A8
BQ1-015-CC	1PH Brake, NEMA 1,110-125 VAC, 50/60Hz	P1
BQ1-015-CP	1PH Brake, Panel 110-125 VAC, 50/60 Hz	P1

No performance data has been assigned to this product.

G7LY0370

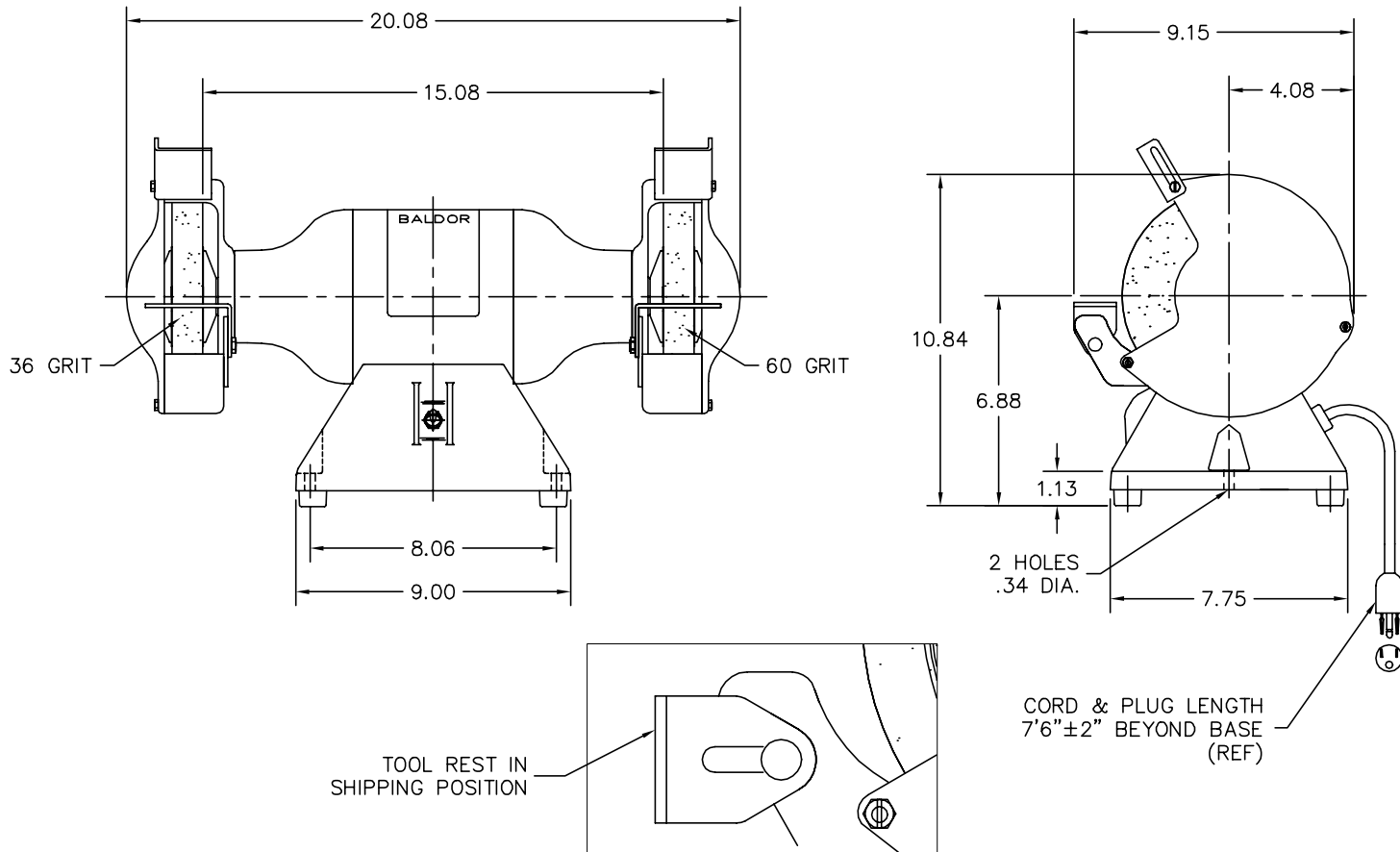

CUSTOMER IS RESPONSIBLE FOR DETERMINING THAT BALDOR'S PRODUCT WILL PERFORM SUITABLY IN THE INTENDED APPLICATION.

REV. DESC: ADD CORD LENGTH REFERENCE PER PLANT		
REV. LTR: T	VERSION: 03	TDR: 000001029878
FILE: \AAA\00100\735	REVISED: 09:10:38 05/25/2017	BY: ENBENBO
MTL: -		

BALDOR

7" UTILITY GRINDER TYPE 420C 115 NON-EXHAUST

SH 1 of 1

G7LY0370

