

**BALDOR® • RELIANCE** 

**Product Information Packet**

**812RE**

**.75HP,3600RPM,1PH,60HZ,3524C,GRND**

Part Detail							
Revision:	BB	Status:	PRD/A	Change #:		Proprietary:	No
Type:	AC	Elec. Spec:	G8WG0011	CD Diagram:	CD0279	Mfg Plant:	
Mech. Spec:	G8-212	Layout:	G8LY0212	Poles:	02	Created Date:	08-08-2007
Base:	RG	Eff. Date:	12-15-2021	Leads:	4#18		

Specs			
Nameplate Output:	.75		

Nameplate NP3118	
CAT.NO.	812RE
HP	.75
PHASE	1
HZ	60
SER.NO.	
SPEC.	G8-212-11
	VOLTS 115/230
	AMPS 4.8/2.4
	RPM 3600

Parts List		
Part Number	Description	Quantity
SA037660	SA G8-212-11	1.000 EA
RA033685	RA G8-212-11	1.000 EA
OC3016F12SP	CYL OIL CAP 16MFD/370V	1.000 EA
G8BA3000	G8 & G10 BASE	1.000 EA
19XX2510A14	1/4-10 X 7/8 HEX HD PLASTITE SCREW	4.000 EA
HW1000A25	1/4 SAE FLAT WASHER (FS)	4.000 EA
HW1003A50	LOCKWASHER, 1/2", EXT. TOOTH ZINC PLATED	1.000 EA
HA6053A01ZP	CLAMP, CAPACITOR 2" DIA, WHITE ZINC PLAT	1.000 EA
51XN1032A04	10-32 X 0.25 HX WS SL SR	3.000 EA
XY1032A02	10-32 HEX NUT DIRECTIONAL SERRATION	3.000 EA
11XW1032G06	10-32 X .38, TAPTITE II, HEX WSHR SLTD U	1.000 EA
HW3001B01	BRASS CUP WASHER, FOR #10 SCREW	1.000 EA
LD5001A02	CORD & PLUG ASSY 18-3 SJT .33 DIA. 10 AM	1.000 EA
WD4102A01	SR-6L-1 HEYCO STRN RELIEF OR 23MPO6L10 M	1.000 EA
G8CB4500A02	G8-272 BASE COVER, STPD X PLATED	1.000 EA
51XW0832A07	8-32 X .44, TAPTITE II, HEX WSHR SLTD SE	2.000 EA
RM1005A01SP	BUMPER- #2089 (R-R CO)	4.000 EA
15XF1032A10	10-32X5/8 PIN HD PHL TY FSEE JT	4.000 EA
G8EP3900A01SP	ENDPLATE, MACH	1.000 EA
G8EP3900A01SP	ENDPLATE, MACH	1.000 EA
HW5100A06	W2420-025 WVY WSHR (WB)	1.000 EA
HW5100A06	W2420-025 WVY WSHR (WB)	1.000 EA
HA1000A34	DR2463A .02 BRG GUARD B N	1.000 EA
HA3100A14	THRUBOLT 10-32 X 7.875	4.000 EA

Parts List (continued)		
Part Number	Description	Quantity
HA1000A34	DR2463A .02 BRG GUARD B N	1.000 EA
XY1032A02	10-32 HEX NUT DIRECTIONAL SERRATION	4.000 EA
G8FH1800A02	GRINDER GUARD, MACH	1.000 EA
19XW2520A16	SCREW,1/4-20X1 TAPTITE-II OR ROLOC 91	4.000 EA
G8FH1802A02	GRINDER GUARD, MACH	1.000 EA
19XW2520A16	SCREW,1/4-20X1 TAPTITE-II OR ROLOC 91	4.000 EA
HA6048A01SP	SUPPORT, TOOL REST, STAMPED PLATED	1.000 EA
10XN2520A08	1/4-20X1/2 HEX HEAD CAP	1.000 EA
HW1001A25	LOCKWASHER 1/4, ZINC PLT .493 OD, .255 I	1.000 EA
HW1000A25	1/4 SAE FLAT WASHER (FS)	1.000 EA
HA6048A01SP	SUPPORT, TOOL REST, STAMPED PLATED	1.000 EA
10XN2520A08	1/4-20X1/2 HEX HEAD CAP	1.000 EA
HW1001A25	LOCKWASHER 1/4, ZINC PLT .493 OD, .255 I	1.000 EA
HW1000A25	1/4 SAE FLAT WASHER (FS)	1.000 EA
G7AP1010A01SP	TOOL REST, LEFT/RIGHT HAND 11GA H.R. STE	1.000 EA
83XN2520A08	1/4-20 X 1/2 LONG CARRIAGE BOLT	1.000 EA
XY2520A12	1/4-20 HEX NUT, DIRECTIONAL SERRATIONS	1.000 EA
G7AP1010A01SP	TOOL REST, LEFT/RIGHT HAND 11GA H.R. STE	1.000 EA
83XN2520A08	1/4-20 X 1/2 LONG CARRIAGE BOLT	1.000 EA
XY2520A12	1/4-20 HEX NUT, DIRECTIONAL SERRATIONS	1.000 EA
G6AP1002A01	SPARK BREAKER-6",7" & 8" GRINDERS	1.000 EA
10XN3118A12	5/16-18 X 3/4 HEX HEAD CAP	1.000 EA
HW1001A31	LOCKWASHER 5/16, ZINC PLT.591 OD, .319 I	1.000 EA
HW1000A31	5/16 SAE FL WSHR NARROW, ID=.344, OD=.62	1.000 EA

Product Information Packet: 812RE - .75HP,3600RPM,1PH,60HZ,3524C,GRND

G6AP1002A01	SPARK BREAKER-6",7" & 8" GRINDERS	1.000 EA
10XN3118A12	5/16-18 X 3/4 HEX HEAD CAP	1.000 EA
HW1001A31	LOCKWASHER 5/16, ZINC PLT.591 OD, .319 I	1.000 EA
HW1000A31	5/16 SAE FL WSHR NARROW, ID=.344, OD=.62	1.000 EA
HA6098	WHEEL FLANGE, CAST	2.000 EA
HA6098	WHEEL FLANGE, CAST	2.000 EA
HW3020E04	1/8 X 3/8 A GROOVE PIN (DRIV-LOCK #118	1.000 EA
HW3020E04	1/8 X 3/8 A GROOVE PIN (DRIV-LOCK #118	1.000 EA
FSG8AP3000A01	A36N5V10 8X1X3/4 36GRIT X	1.000 EA
G8AP3000A02	A60N6V10 8X1X3/4 60GRIT X	1.000 EA
XY7510A12SP	3/4-10 NUT R.H. HEX (NC) ZINC PLATED	1.000 EA
XY7510A62	3/4-10 NUT L.H. HEX (NC) (F/S)	1.000 EA
G8FH1801A01SP	GUARD COVER - R.H. 8" GRINDER	1.000 EA
10XN2520A16	1/4-20 X 1 HEX HEAD CAP SCR, ZINC PLATED	4.000 EA
G8FH1803A01SP	GUARD COVER - L.H. 8" GRINDER	1.000 EA
10XN2520A16	1/4-20 X 1 HEX HEAD CAP SCR, ZINC PLATED	4.000 EA
G7AP5001A01	EYE SHIELD ASSEM.-7",8",10",12"&14"GRIND	1.000 EA
SP9000SP	80600BJ A-H OR 1520237-2 TYCO;2PST,125/2	1.000 EA
MJ1000A02	GREASE, MOBIL POLYREX EM - 124047	0.050 LB
MG1000R01	400-0113 H/F BALDOR BIG RED LAC (5G)	0.017 GA
85XU0407A04	#4-7 X 1/4 DRIVE PIN	2.000 EA
LC0279A01	1PH, DV, FIX, GRINDER, CONN FOR LV	1.000 EA
MG1500G03-5	LACQUER PRIMER, GRAY - 5 GAL	0.010 GA
LB1119N	WARNING LABEL	1.000 EA
LB1591A01	CONSOLIDATED GRINDER LABEL FOR 6", 7", 8	1.000 EA
NP3118	ALUM GRINDERS-BUFFERS NO LOGO'S	1.000 EA

Product Information Packet: 812RE - .75HP,3600RPM,1PH,60HZ,3524C,GRND

G0PA1000	PKG GRP, PRINT PK1026A06	1.000 EA
MN903	INSTR MANUAL FOR GRINDERS 9/03	1.000 EA
LB1618	PROPOSITION 65 WARNING LABEL 1-1/2 X 1/2	1.000 EA

<b>Accessories</b>		
<b>Part Number</b>	<b>Description</b>	<b>Multiplier</b>
GA16RE	PEDESTAL LIGHT INDUSTRIAL,STEEL-RED	A8
GA14R	PEDESTAL FABRICATED STEEL W/SHELVES-RED	A8
GA16R	PEDESTAL IND., CAST IRON 6" - 10" RED	A8
B80	8" 36 GRIT GRINDING WHEEL	A8
B81	8" 60 GRIT GRINDING WHEEL	A8
GA9R	PAIR LIGHTED EYESHIELDS-RED	A8
GA9SR	PAIR LIGHTED EYESHIELD W/ON-OFF-RED	A8
DC8	DUST CONTROL UNIT	A8
BQ1-015-CC	1PH Brake, NEMA 1,110-125 VAC, 50/60Hz	P1
BQ1-015-CP	1PH Brake, Panel 110-125 VAC, 50/60 Hz	P1



No performance data has been  
assigned to this product.

GBLY0212

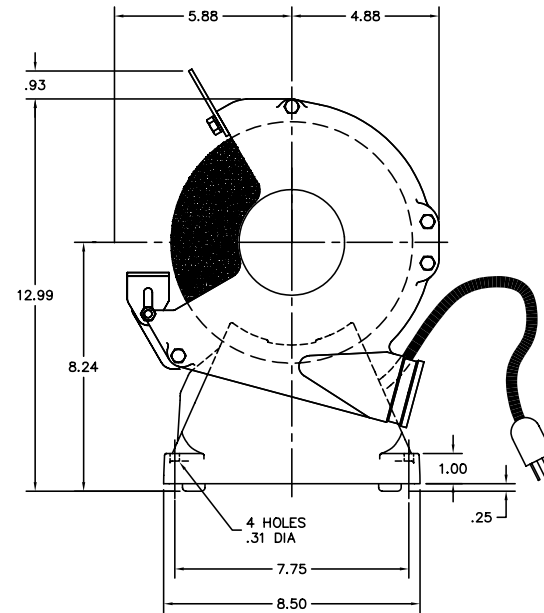
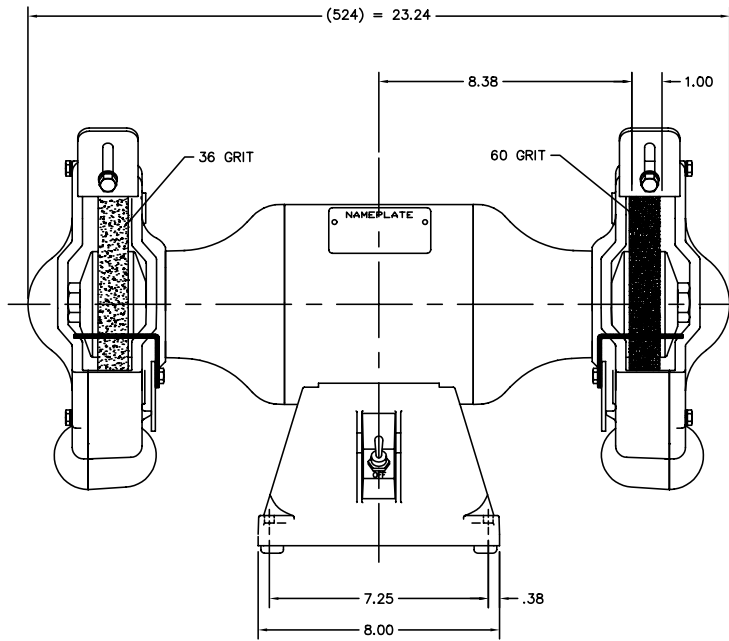

CUSTOMER IS RESPONSIBLE FOR DETERMINING THAT MOTOR PERFORMANCE IS SUITABLE IN THE APPLICATION.

REV. DESC:	OMITTED FELT WSHR HA1025A03 & CHG'D TO SEALED BRGS
REV. LTR:	H BY: SSS REVISED: 10/02/00 1:39 TDR: 0212666
FILE:	AAA00036238 REF: -
MTL:	-

**BALDOR ELECTRIC Co.**

STD 8" UTILITY GRINDER 524C W/115V CORD/PLUG

GBLY0212

