

ENCLOSURE NOTES:
 - ENVIRONMENTAL RATING: UL TYPE 3R
 - PAINT COLOR: WHITE

DIMENSIONS ARE FOR REFERENCE ONLY. IN[mm]

CONTROL OPTION NOTE:
 DEVICE PLACEMENT IS DETERMINED BY THESE DIGITS OF UNIT PART NUMBER

AS3P4___AA___[- - - -] -

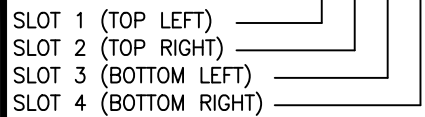

OPTIONAL 30mm CONTROL DEVICE DETAILS

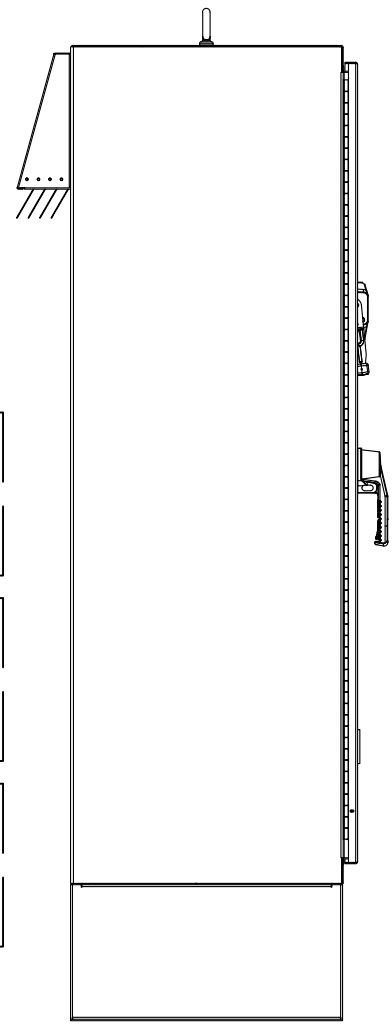
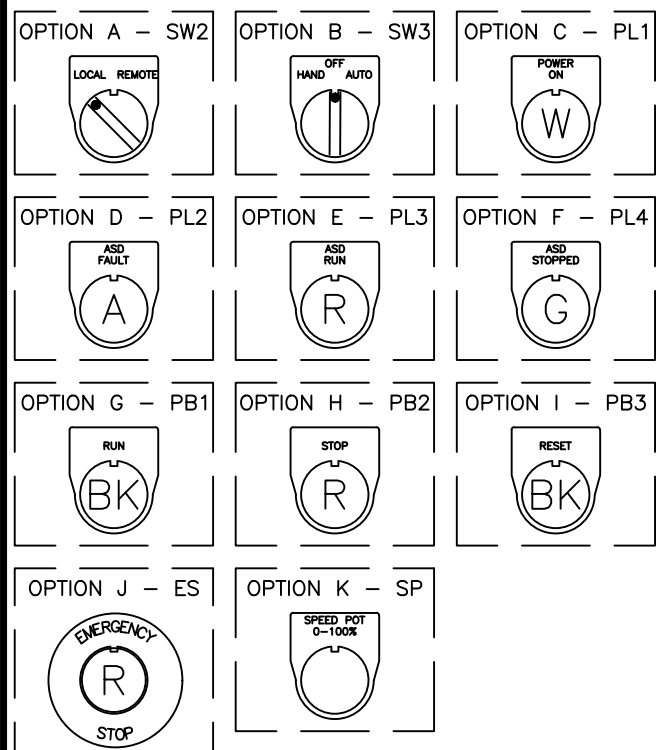

LEFT SIDE VIEW

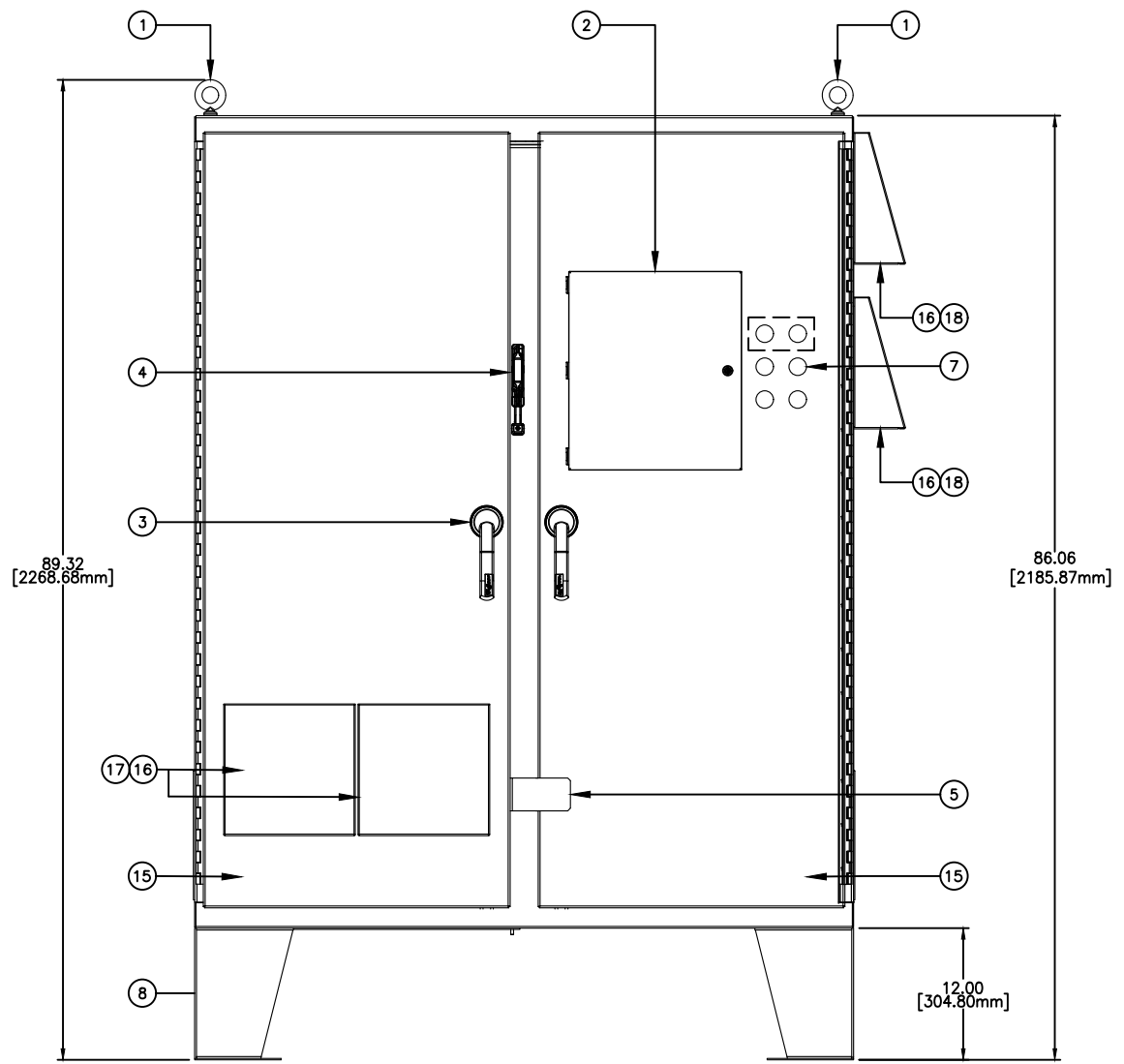

FRONT VIEW

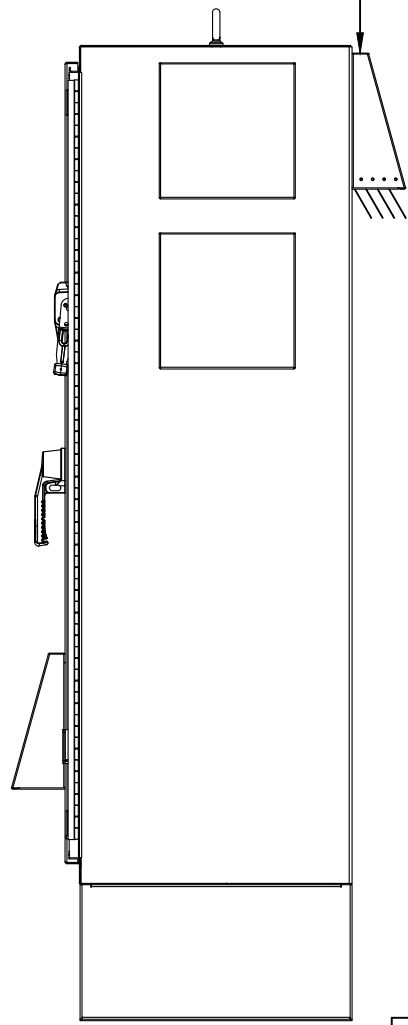

RIGHT SIDE VIEW

DO NOT BLOCK LOUVERS, RECOMMEND 12" CLEARANCE

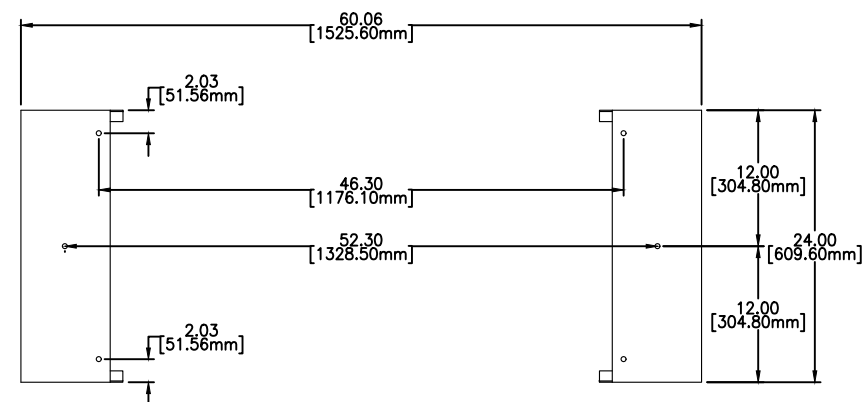

LEG STAND KIT MOUNTING

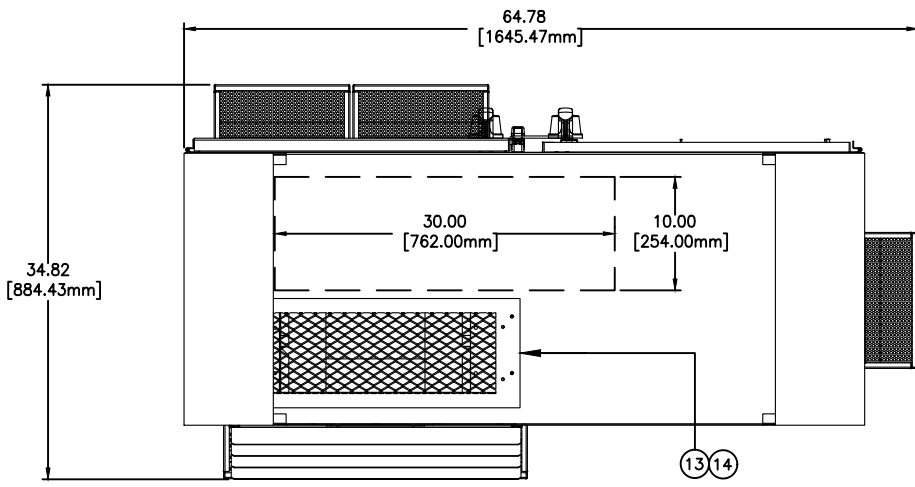

BOTTOM VIEW

ASD INTAKE, DO NOT BLOCK

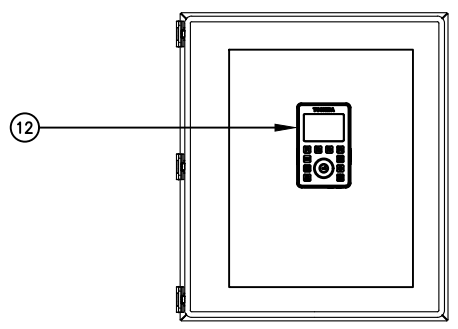

CONTROLLER VIEW (NTS)

ITEM	DESCRIPTION
1	LIFTING EAR
2	HINGED CONTROL DOOR
3	HANDLE
4	CIRCUIT DISCONNECT SWITCH
5	INTERLOCK PLATE
6	N/A
7	HOLE PLUGS/PILOT DEVICE HOLE
8	LEG STAND
9	ASD EXHAUST SHROUD
10	AIR DIVERTER
11	MESH FILTER
12	OPERATOR KEYPAD (EOI)
13	EXPANDED METAL/ASD HEATSINK INTAKE
14	MESH FILTER
15	DOOR STOP (INTERNAL)
16	FAN SHROUD
17	FILTERED INTAKE FAN
18	FILTERED EXHAUST FAN
19	N/A
20	N/A

4					
3					
2					
1					
0	09/03/21	FIRST ISSUE	E.YANG	S.EARY	J.ONG
REV	DATE	DESCRIPTION	BY	CHK	APPR

TOSHIBA
 TOSHIBA INTERNATIONAL CORPORATION
 MADE IN HOUSTON, TEXAS U.S.A.

THIS MATERIAL IS THE EXCLUSIVE PROPERTY OF TOSHIBA INTERNATIONAL CORPORATION AND SHALL NOT BE REPRODUCED, USED, OR DISCLOSED TO OTHERS UNLESS PRIOR WRITTEN AUTHORIZATION IS OBTAINED.

TITLE:
 ENCLOSURE OUTLINE
 AS3P4(160~280)KAA

REVISION:	0	SCALE:	1.0=18.0
DRAWING NUMBER:		1808WG23	