

TOSHIBA/HOUSTON TOTALLY-ENCLOSED FAN-COOLED HORIZONTAL FOOT-MOUNTED (O.D.E ROLLER BRG) **Fr. 5010USS**
2-POLE
350-500Hp

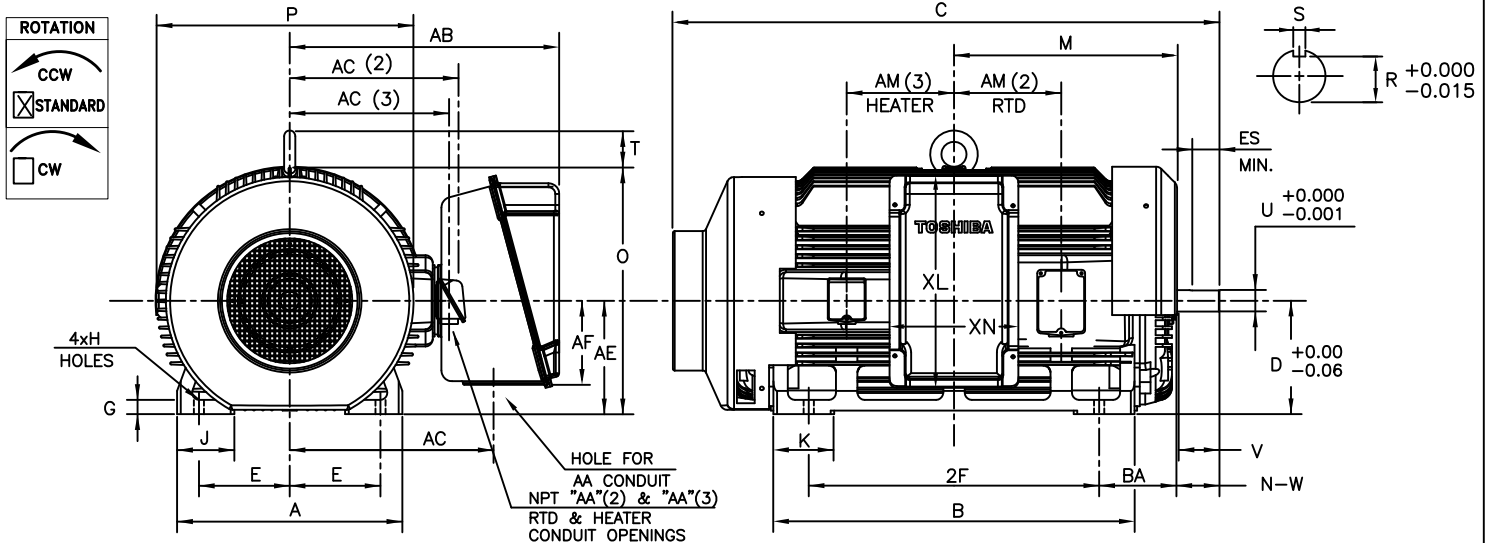

UNITS: INCHES

FRAME SIZE	MOUNTING				CONDUIT BOX						
	E	2F	H	BA	AA[NPT]	AB	AC	AE	AF	XL	XN
5010USS	10.00	32.0	1.12	8.50	4.00	29.7	22.5	12.5	9.3	23.4	14.2

FRAME SIZE	MOTOR DIMENSIONS										
	A	B	C	D	G	J	K	M	O	P	T
5010USS	24.8	39.8	60.2	12.50	1.6	6.3	6.7	24.6	27.2	28.4	4.3

FRAME SIZE	SHAFT EXTENSION			KEY SEAT			BEARINGS		MAXIMUM WEIGHT
	N-W	V	U	R	S	ES	LS	OS	
5010USS	4.75	4.50	2.375	2.021	0.625	3.03	6313C3	NU313C3	4637 lbs.

FRAME SIZE	RTD AUX. BOX					HEATER AUX. BOX				
	AA(2)	AC(2)	AE	AF(2)	AM(2)	AA(3)	AC(3)	AE	AF(3)	AM(3)
5010USS	1.5	15.58	12.5	5.1	11.8	0.75	11.3	12.5	2.56	11.81

MOTOR WITH

- AUX. RTD BOX
- AUX. HEATER BOX
- BOTH AUX. BOXES

ALL DATA SUBJECT TO CHANGE WITHOUT NOTICE.
 FOR CONSTRUCTION USE ONLY CERTIFIED DATA.

CERTIFIED DATA

NOTES:

1. DIMENSION V REPRESENTS LENGTH OF STRAIGHT PART OF SHAFT.
2. CONDUIT BOX MAY BE ROTATED IN 90° INCREMENTS AND MAY BE MOUNTED ON OPPOSITE SIDE ON SPECIAL ORDER.
3. KEY DIMENSIONS EQUAL S x S x 3.00 (MOTOR SUPPLIED WITH KEY)
4. MOTOR WEIGHT SHOWN IS MAXIMUM HORSEPOWER IN FRAME.
5. STANDARD UNITS USE UNI-DIRECTIONAL FAN. OPPOSITE ROTATION AVAILABLE ONLY BY FAN AND CONNECTION CHANGE.

CUSTOMER: _____ P.O. NO.: _____ TAG NO.: _____

MOTOR MODEL NO.: _____ TOSHIBA FILE NO.: _____

HP: _____ RPM (SYN.): _____ VOLTAGE: _____ Hz: _____

FRAME SIZE: _____ LOG NO.: _____ LOG REV. LEVEL: _____

REMARKS: _____

PER: _____ ISSUE DATE: _____ SUPERSEDES: _____



Issued Date	9/24/2019	Transmit #	
Issued By	dschoeck	Issued Rev	

TYPICAL MOTOR PERFORMANCE DATA

Model: B3503FLG8OMH

HP	kW	Pole	FL RPM	Frame	Voltage	Hz	Phase	FL Amps
350	261	2	3580	5010USS	575	60	3	295
Enclosure	IP	Ins. Class	S.F.	Duty	NEMA Nom. Eff.	NEMA Design	kVA Code	Ambient (°C)
TEFC	54	F	1.15	CONT	95.8	B	F	40 C

Load	HP	kW	Amperes	Efficiency (%)	Power Factor (%)
Full Load	350	261.0	295.2	95.4	93.0
¾ Load	262.50	195.7	225.0	94.5	92.3
½ Load	175.00	130.5	157.8	92.6	89.6
¼ Load	87.50	65.2	96.6	86.8	78.0
No Load			51.0		18.9
Locked Rotor			1868.73151310676		26.6

Torque				Rotor wk ² Inertia (lb-ft ²)
Full Load (lb-ft)	Locked Rotor (% FLT)	Pull Up (% FLT)	Break Down (% FLT)	
514	145	110	230	129.14

Safe Stall Time(s)		Sound Pressure dB(A) @ 1M	Bearings*		Approx. Motor Weight (lbs)
Cold	Hot		DE	NDE	
34	12	-	6313C3	NU313C3	3975

*Bearings are the only recommended spare part(s).

Motor Options:
 Product Family:EQP Global SD
 Mounting:Footed,Shaft:USS Shaft

Customer	
Customer PO	
Sales Order	
Project #	

Tag:

All characteristics are average expected values.

TOSHIBA INTERNATIONAL CORPORATION · HOUSTON, TEXAS U.S.A.

Engineering	bmmamen	Doc. Written By	D. Suarez	Doc.# / Rev	MPCF-1119 / 1
Engr. Date	10/18/2018	Doc. Approved By	M. Campbell	Doc. Issued	9/20/2019



Issued Date	9/24/2019	Transmit #	
Issued By	dschoeck	Issued Rev	

SPEED TORQUE/CURRENT CURVE

Model: B3503FLG80MH

HP	kW	Pole	FL RPM	Frame	Voltage	Hz	Phase	FL Amps
350	261	2	3580	5010USS	575	60	3	295
Enclosure	IP	Ins. Class	S.F.	Duty	NEMA Nom. Eff.	NEMA Design	kVA Code	Ambient (°C)
TEFC	54	F	1.15	CONT	95.8	B	F	40 C
Locked Rotor Amps	Rotor wk ² Inertia (lb-ft ²)	Torque				Pull Up (%)	Break Down (%)	
		Full Load (lb-ft)	Locked Rotor (%)					
868.73151310676	129.14	514	145		110	230		

Design Values

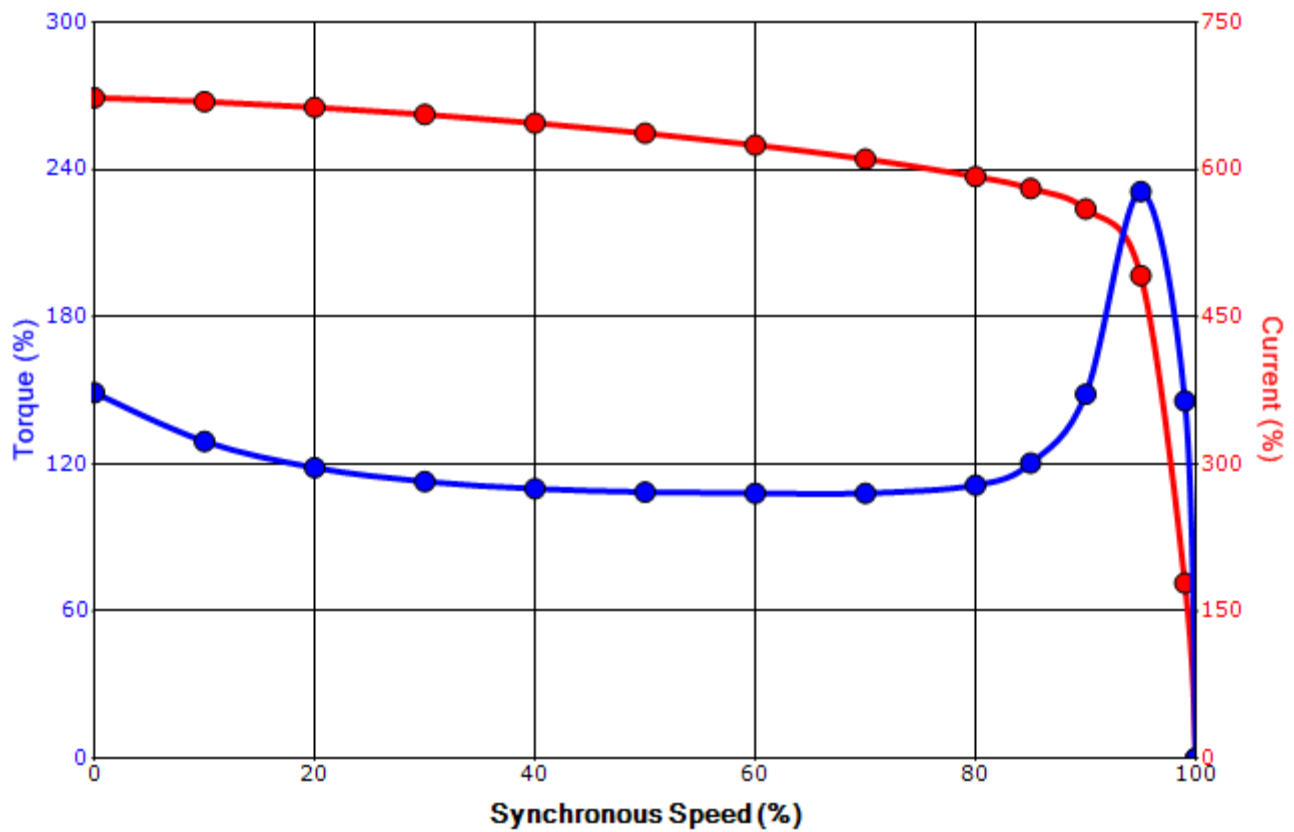

Customer		wk ² Load Inertia (lb-ft ²)	-
Customer PO		Load Type	-
Sales Order		Voltage (%)	100
Project #		Accel. Time	-

Tag:

All characteristics are average expected values.

TOSHIBA INTERNATIONAL CORPORATION · HOUSTON, TEXAS U.S.A.

Engineering	bmammen	Doc. Written By	D. Suarez	Doc.# / Rev	MPCF-1121/1
Engr. Date	10/18/2018	Doc. Approved By	M. Campbell	Doc. Issued	9/20/2019

Motor Connection Diagrams
6 Leads

Across the Line Starting / Run - Delta:



Alternate Starting Connection - Wye:

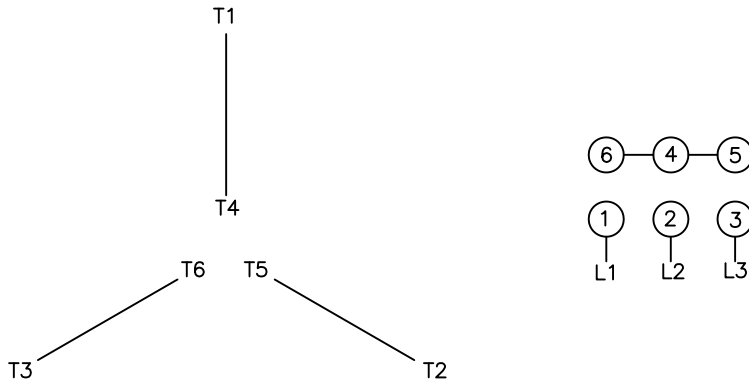

Switch L1 and L2 to reverse rotation