

CATALOG No: **BC2N125-5C**

ISSUED: 28-Feb-24

GENERAL INFORMATION

HP	KW	Pole	RPM	Frame	Voltage	Hz	Phase	IP Rating
125	90.00	2	3600	444TSC	575 V	60	3	IP55

Enclosure	Ins. Class	Service Factor	Time Rating	NEMA Design	Rated Amb.	Rated Altitude
TEFC	F	1.25	Continuous	B	-15 to 40 C°	<3300 ft

TYPICAL PERFORMANCE

Efficiency (%)			Power Factor (%)		
Full Load	3/4 Load	1/2 Load	Full Load	3/4 Load	1/2 Load
95.0	94.5	93.7	0.90	0.88	0.84

LRT%	BDT %	Full Load Amps	Locked Rotor Amps	Full Load RPM
		575 V	575 V	
180	300	109.60	726.40	3555

NEMA KVA Code	Bearing Size		Oil Seal		Sound Level
	Drive End	Non-Drive End	Drive End	Non-Drive End	dB(A)
G	6314.00	6314.00	70 x 90 x 10	70 x 90 x 10	81

*Weights shown are estimated and based on standard foot mounted motor designs

VFD DUTY INFORMATION

	Variable Torque	Constant Torque	Rating
-	3 - 60 Hz	4 - 60 Hz	CSA Approved Class I; Div 2; Groups A, B, C, & D, T3
-	-	-	

Click Link Below For Drawing

<http://brookcromptonna.com/Drawings/W-NEMA/NEMA%20Cast%20Iron%20B34/WP-DF444TSC.pdf>

Click Link Below For Connection Diagram

<http://www.brookcromptonna.com/Connections/Connection%20Diagram%206%20Lead%20575%20NEMA.pdf>

Notes:

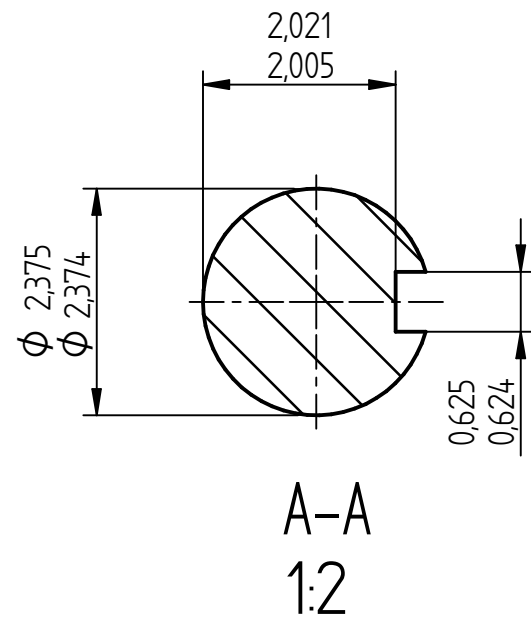
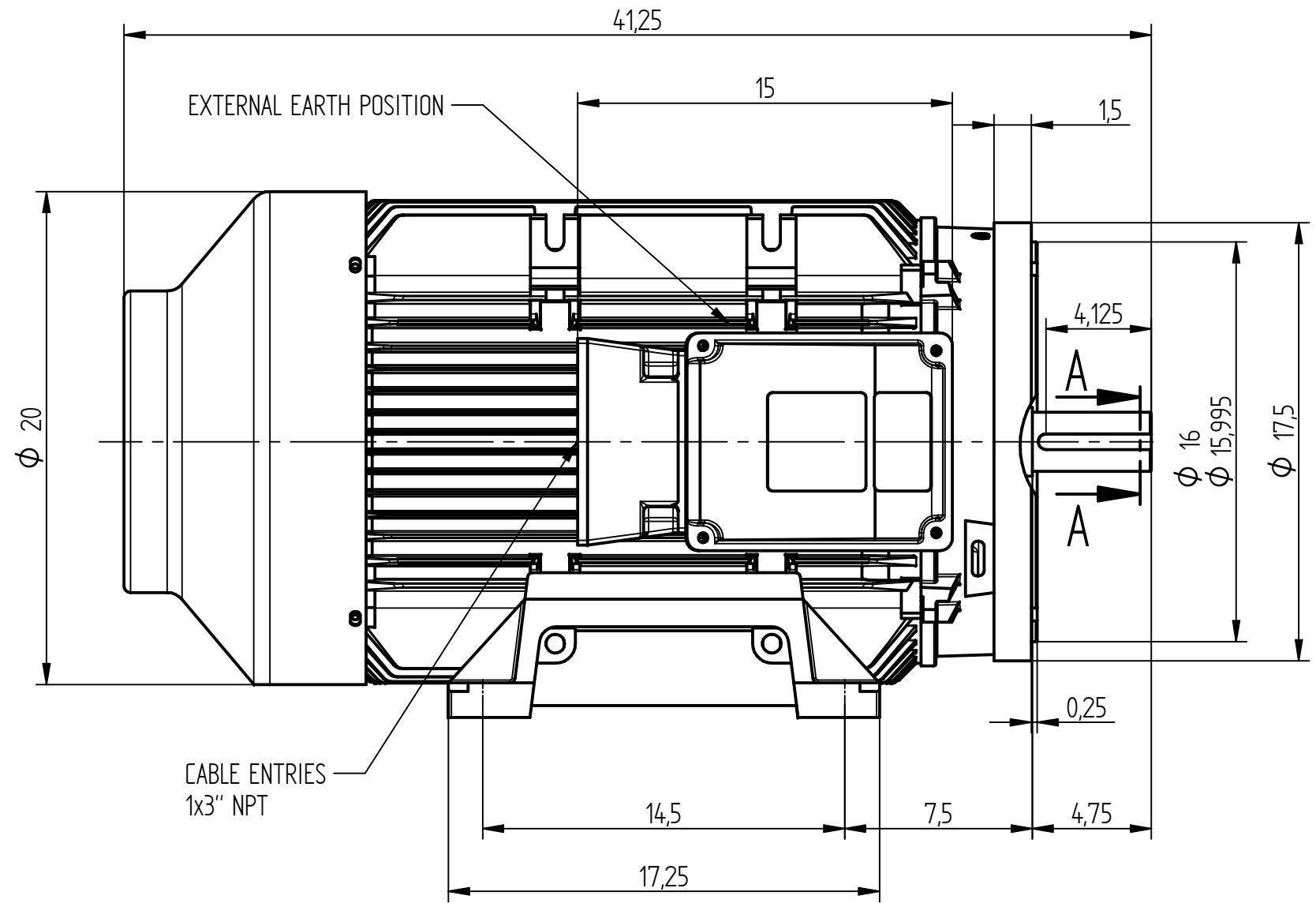
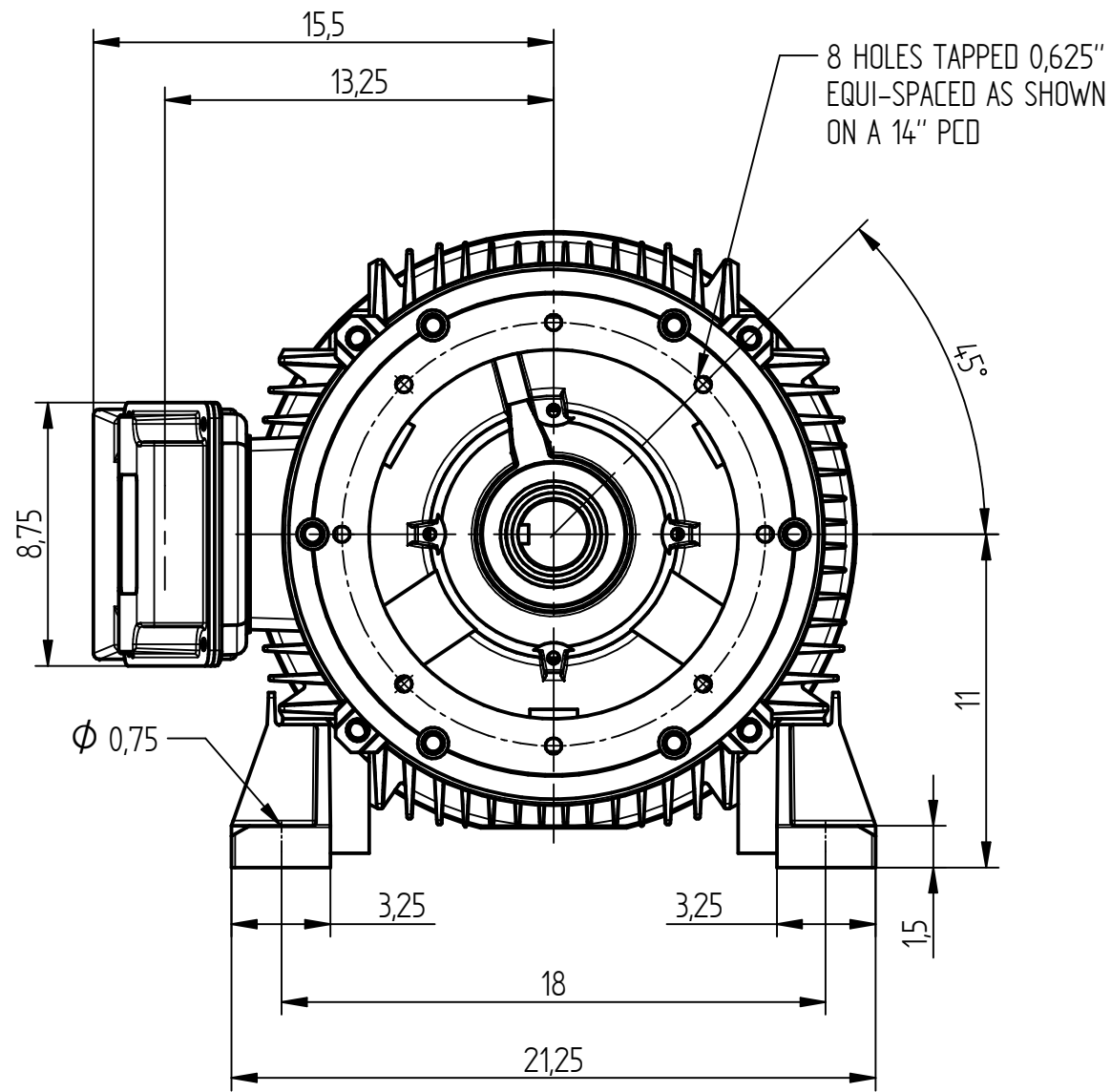

STANDARD TERMINAL BOX POSITION IS 9 O'CLOCK AS SHOWN.
 CONDUIT ENTRIES: - TERMINAL BOX CAN BE ROTATED AT 90° INTERVALS
 (CONDUIT ENTRY POSITION SHOWN FOR ILLUSTRATION ONLY)

ALL DIMENSIONS IN INCHES	
	FIRST ANGLE PROJECTION
BROOK CROMPTON	
Produced by <i>Tamel S.p.A.</i> a company of NFB	
DRG. No.	
DRG. REF.	
REVISION:	DATE:

SHEET SIZE A3	TITLE:	OUTLINE DIMENSION DRAWING W CAST IRON TOTALLY ENCLOSED FAN COOLED WP-DF444TS-NE FRAME FOOT & C FLANGE MOUNTED MOTOR
	NAME	PG
	DATE	08-07-16
	SCALE	1:6