

CATALOG No: **BC2N150-9D**

ISSUED: 28-Feb-24

GENERAL INFORMATION

HP	KW	Pole	RPM	Frame	Voltage	Hz	Phase	IP Rating
150	110.00	2	3600	445TSD	460 V	60	3	IP55

Enclosure	Ins. Class	Service Factor	Time Rating	NEMA Design	Rated Amb.	Rated Altitude
TEFC	F	1.25	Continuous	B	-15 to 40 C°	<3300 ft

TYPICAL PERFORMANCE

Efficiency (%)			Power Factor (%)		
Full Load	3/4 Load	1/2 Load	Full Load	3/4 Load	1/2 Load
95.0	94.5	93.5	0.92	0.91	0.88

LRT%	BDT %	Full Load Amps	Locked Rotor Amps	Full Load RPM
		460 V	460 V	
160	280	161.00	1085.00	3575

NEMA KVA Code	Bearing Size		Oil Seal		Sound Level
	Drive End	Non-Drive End	Drive End	Non-Drive End	dB(A)
G	6316.00	6316.00	70 x 90 x 10	70 x 90 x 10	82

*Weights shown are estimated and based on standard foot mounted motor designs

VFD DUTY INFORMATION

	Variable Torque	Constant Torque	Rating
-	3 - 60 Hz	4 - 60 Hz	CSA Approved Class I; Div 2; Groups A, B, C, & D, T3
-	-	-	

Click Link Below For Drawing

<http://brookcromptonna.com/Drawings/W-NEMA/NEMA%20Cast%20Iron%20B35/WP-DF445TSD.pdf>

Click Link Below For Connection Diagram

<http://www.brookcromptonna.com/Connections/Connection%20Diagram%206%20Lead%20460V%20NEMA.pdf>

Notes:

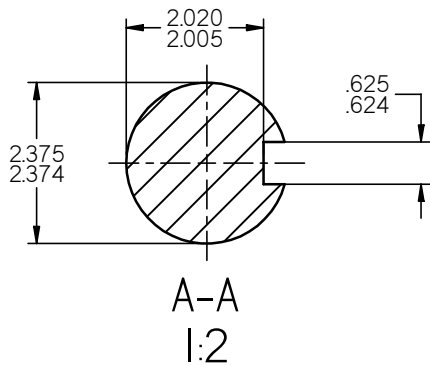
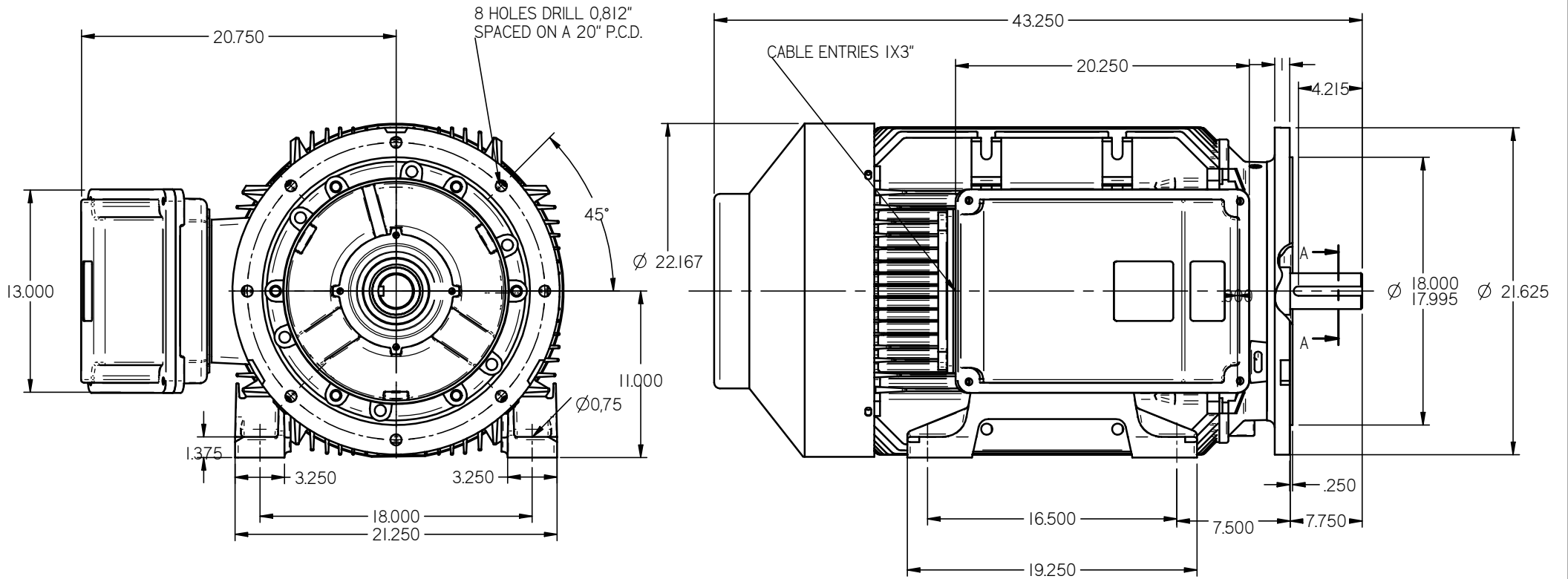

STANDARD TERMINAL BOX POSITION IS 9 O'CLOCK AS SHOWN.
 CONDUIT ENTRIES:- TERMINAL BOX CAN BE ROTATED AT 90°
 INTERVALS
 (CONDUIT ENTRY POSITION SHOWN FOR ILLUSTRATION ONLY)

ALL DIMENSIONS IN INCHES

FIRST ANGLE
 PROJECTION

**BROOK
 CROMPTON**

SHEET SIZE: **A3**
 TITLE: **OUTLINE DIMENSION DRAWING W CAST IRON TOTALLY ENCLOSED FAN COOLED WP-DF445TSD-NE FRAME FOOT/D-FLANGE MOUNTED MOTOR**

NAME	DATE	DRG. No.
IS	26-03-2013	DRG. REF.
CHECKED		REVISION:
SCALE	1:6	DATE: