

CATALOG No: **BC4N150-9C**

ISSUED: 28-Feb-24

**GENERAL INFORMATION**

HP	KW	Pole	RPM	Frame	Voltage	Hz	Phase	IP Rating
150	110.00	4	1800	445TC	460 V	60	3	IP55

Enclosure	Ins. Class	Service Factor	Time Rating	NEMA Design	Rated Amb.	Rated Altitude
TEFC	F	1.25	Continuous	B	-15 to 40 C°	<3300 ft

**TYPICAL PERFORMANCE**

Efficiency (%)			Power Factor (%)		
Full Load	3/4 Load	1/2 Load	Full Load	3/4 Load	1/2 Load
95.8	95.9	95.0	0.86	0.85	0.80

LRT%	BDT %	Full Load Amps	Locked Rotor Amps	Full Load RPM
		460 V	460 V	
190	210	170.00	1085.00	1780

NEMA KVA Code	Bearing Size		Oil Seal		Sound Level
	Drive End	Non-Drive End	Drive End	Non-Drive End	dB(A)
G	6319.00	6319.00	90 x 120 x 12	90 x 120 x 12	76

\*Weights shown are estimated and based on standard foot mounted motor designs

**VFD DUTY INFORMATION**

	Variable Torque	Constant Torque	Rating
-	3 - 60 Hz	4 - 60 Hz	CSA Approved Class I; Div 2; Groups A, B, C, & D, T3
-	-	-	

**Click Link Below For Drawing**

<http://brookcromptonna.com/Drawings/W-NEMA/NEMA%20Cast%20Iron%20B34/WP-DF445TC.pdf>

**Click Link Below For Connection Diagram**

<http://www.brookcromptonna.com/Connections/Connection%20Diagram%206%20Lead%20460V%20NEMA.pdf>

Notes:

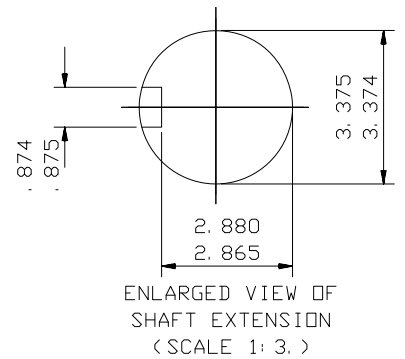
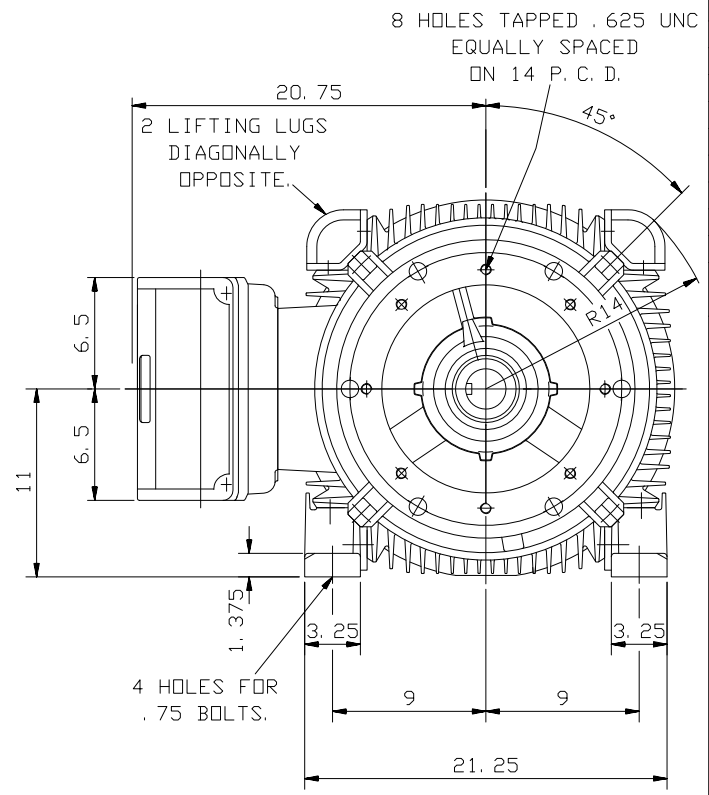
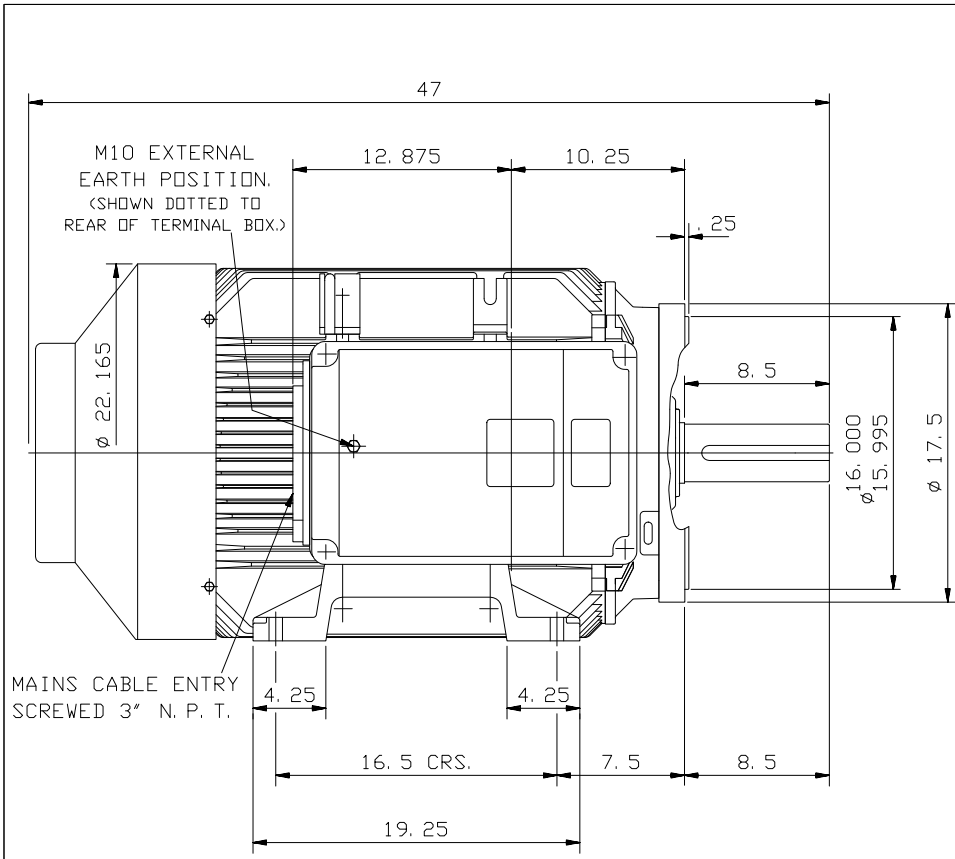

NOTE! TERMINAL BOX CAN BE TOP MOUNTED BY REFITTING FEET 90° IN APPROPRIATE DIRECTION. CABLE ENTRY CAN BE SUPPLIED IN ANY ONE OF FOUR POSITIONS AT 90° INTERVALS.

CUSTOMER		
ORDER No.		
SERIAL No.		
FRAME SIZE		
kw	RPM.	
Hz	PHASE 3	
VOLTS	POLES	
BRGS.	DE.	NDE.
MOTOR NETT. WT.	Kg.	
INSULATION CLASS		
TEMPERATURE RISE °C		
DESIGN AMBIENT TEMPERATURE °C		
HEATER WATTS & VOLTS		
	WATTS,	VOLTS

REMARKS

ALL DIMENSIONS IN MILLIMETRES

FIRST ANGLE PROJECTION



NOTE ! 2.5 ENDPLAY WILL BE PROVIDED FOR ENDTHRUST PROTECTION WHEN CUSTOMERS NOTIFY US OF THEIR INTENTION TO USE RIGID COUPLINGS AND DRIVEN MACHINES WITHOUT ENDPLAY.

OUTLINE DIMENSIONS OF STANDARD FOOT/C FACE MOUNTED INCH A. C. MOTOR TO NEMA STD. MG1. TOTALLY ENCLOSED FAN COOLED. FITTED WITH SIDE MOUNTED TERMINAL BOX. FRAME SIZE: W-DF445TC-E ( 4 POLE UP. )

SCALE		DATE
DRAWN		
CHECKED		
APPROVED		

DRG. No.	
REVISION:	DATE