

CATALOG No: **BC6N100-5D**

ISSUED: 28-Feb-24

**GENERAL INFORMATION**

HP	KW	Pole	RPM	Frame	Voltage	Hz	Phase	IP Rating
100	75.00	6	1200	444TD	575 V	60	3	IP55

Enclosure	Ins. Class	Service Factor	Time Rating	NEMA Design	Rated Amb.	Rated Altitude
TEFC	F	1.25	Continuous	B	-15 to 40 C°	<3300 ft

**TYPICAL PERFORMANCE**

Efficiency (%)			Power Factor (%)		
Full Load	3/4 Load	1/2 Load	Full Load	3/4 Load	1/2 Load
95.0	94.7	94.4	0.86	0.84	0.75

LRT%	BDT %	Full Load Amps	Locked Rotor Amps	Full Load RPM
		575 V	575 V	
220	200	92.00	708.40	1180

NEMA KVA Code	Bearing Size		Oil Seal		Sound Level
	Drive End	Non-Drive End	Drive End	Non-Drive End	dB(A)
H	6316.00	6316.00	90 x 120 x 12	90 x 120 x 12	73

\*Weights shown are estimated and based on standard foot mounted motor designs

**VFD DUTY INFORMATION**

	Variable Torque	Constant Torque	Rating
-	3 - 60 Hz	4 - 60 Hz	CSA Approved Class I; Div 2; Groups A, B, C, & D, T3
-	-	-	

**Click Link Below For Drawing**

<http://brookcromptonna.com/Drawings/W-NEMA/NEMA%20Cast%20Iron%20B35/WP-DF444TD.pdf>

**Click Link Below For Connection Diagram**

<http://www.brookcromptonna.com/Connections/Connection%20Diagram%206%20Lead%20575%20NEMA.pdf>

Notes:

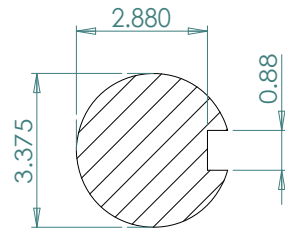
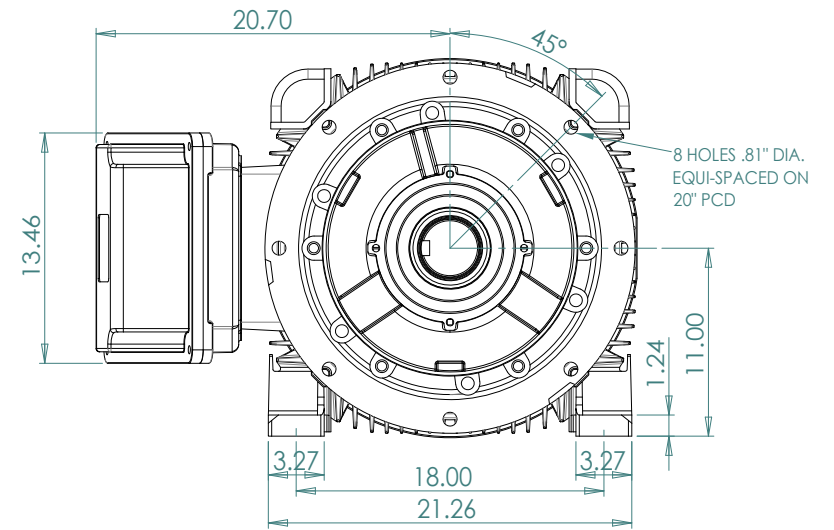
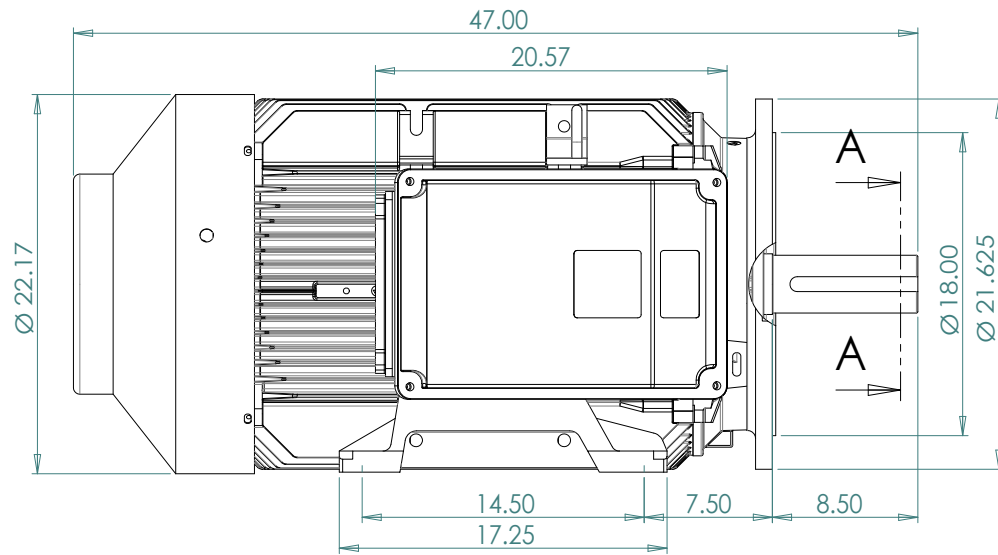

SECTION A-A  
SCALE 1:3

<b>BROOK CROMPTON</b>	
WP-DF444TD	A3
SHEET	www.brookcrompton.com