

BALDOR® • RELIANCE 

Product Information Packet

CCPX21126T

10HP,3490//2900RPM,3PH,60HZ,215TCY,XPFC,

Part Detail							
Revision:	C	Status:	PRD/A	Change #:		Proprietary:	No
Type:	AC	Elec. Spec:	07WGY855	CD Diagram:	CD0005	Mfg Plant:	
Mech. Spec:		Layout:	07LY-000-074	Poles:	02	Created Date:	05-08-2019
Base:		Eff. Date:	04-13-2021	Leads:	9#14		

Specs			
Catalog Number:	CCPX21126T	Electrically Isolated Bearing:	Not Electrically Isolated
Enclosure:	XPFC	Enclosure Modification:	Severe Duty Features
Frame:	215TCY	Feedback Device:	NO FEEDBACK
Frame Material:	Iron	Heater Indicator:	No Heater
Output @ Frequency:	10.000 HP @ 60 HZ	Insulation Class:	F
	7.500 HP @ 50 HZ	Inverter Code:	Inverter Duty
Synchronous Speed @ Frequency:	3600 RPM @ 60 HZ	IP Rating:	IP55
Voltage @ Frequency:	230.0 V @ 60 HZ	KVA Code:	G
	380.0 V @ 50 HZ	Lifting Lugs:	Standard Lifting Lugs
	460.0 V @ 60 HZ	Locked Bearing Indicator:	Locked Bearing
	190.0 V @ 50 HZ	Motor Lead Termination:	Flying Leads
XP Class and Group:	CLI GP C,D; CLII GP E,F,G	Motor Type:	0730M
XP Division:	Division I	Mounting Arrangement:	F1
Agency Approvals:	UR	Power Factor:	87
	CSA EEV	Product Family:	General Purpose
	CSA	Pulley Face Code:	C-Face
Auxillary Box:	No Auxillary Box	Rodent Screen:	None
Auxillary Box Lead Termination:	None	RoHS Status:	ROHS NON-COMPLIANT

Base Indicator:	Rigid	Shaft Ground Indicator:	No Shaft Grounding
Bearing Grease Type:	Polyrex EM (-20F +300F)	Shaft Rotation:	Reversible
Blower:	None	Speed Code:	Single Speed
Constant Torque Speed Range:	6	Motor Standards:	NEMA
Current @ Voltage:	23.600 A @ 230.0 V	Starting Method:	Direct on line
	21.600 A @ 190.0 V	Thermal Device - Bearing:	None
	11.800 A @ 460.0 V	Thermal Device - Winding:	Normally Closed Thermostat
	11.000 A @ 380.0 V	Vibration Sensor Indicator:	No Vibration Sensor
Design Code:	B	Winding Thermal 1:	None
Drip Cover:	No Drip Cover	Winding Thermal 2:	None
Duty Rating:	CONT	XP Temp Code:	T3C

Nameplate NP2033XPSLEV											
NO.						CC	010A				
S/N						TEMP CODE	T3C				
SPEC.	07-0000-0109					INV.TYPE	PWM				
CAT.NO.	CCPX21126T					C HP FR	60		C HP TO	90	
HP	10//7.5					CT HZ FROM	6		CT HZ TO	60	
VOLTS	230/460//190/380					VT HZ FROM	6		VT HZ TO	60	
AMPS	23.6/11.8//21.6/11					MAG CUR	7.2/3.6				
RPM	3490//2900					MX RPM	5400				
HZ	60//50		PH	3		CL	F		NOM.EFF.	90.2	
SER.F.	1.00		DES	B		SL HZ	1.8		WK2	0.273	
FRAME	215TCY		RATING	40C AMB-CONT							
BLANK	55C AMB @ 1.0 SF										
	1.15 SF ON SINEWAVE					NEMA MG-1 PT 5,IP55					

Parts List		
Part Number	Description	Quantity
SA369354	SA 07-0000-0109	1.000 EA
RA358913	RA 07-0000-0109	1.000 EA
LB1115N	LABEL,LIFTING DEVICE (ON ROLLS)	1.000 EA
LB1119N	WARNING LABEL	1.000 EA
LC0145B01	CONNECTION LABEL	1.000 EA
NP2033XPSLEV	SS XP INV UL CSA-EEV CC CL-I GP-C&D	1.000 EA
85XU0407S04	4X1/4 U DRIVE PIN STAINLESS	2.000 EA
85XU0407S04	4X1/4 U DRIVE PIN STAINLESS	4.000 EA
MN416A01	TAG-INSTAL-MAINT no wire (2100/bx) 4/22	1.000 EA
LB1081F	ALUM XP CAUTION LABEL (FS PLANT ONLY-	1.000 EA
LB9002A50	CMC-5000 BRADY WIRE MARK	1.000 EA
HW3201A05	3/8-16 EYEBOLT	1.000 EA
07FH1003A05G	FAN HOUSING 307 EXPLOSION PROOF W/ GREAS	1.000 EA
10XN2520A12	1/4-20 X 3/4 HEX HEAD CAP	4.000 EA
36FN3000C02SP	EXFN, PLASTIC, 5.25 OD, 1.175 ID	1.000 EA
51XB1214A16	12-14X1.00 HXWSSLD SERTYB	1.000 EA
MJ1000A02	GREASE, MOBIL POLYREX EM - 124047	0.050 LB
07EP1707A22G	FRONT ENDPLATE EXPLOSION PROOF(GROUP C &	1.000 EA
10XN3816K28	3/8-16 X 1.75 HEX HD CAP SCREW, GRADE 5	4.000 EA
HW1001A38	LOCKWASHER 3/8, ZINC PLT .688 OD, .382 I	4.000 EA
HA2009A25	SLINGER, FOR GROUP E MOTORS - 206 BRG.	1.000 EA
80XN0632A10	SET SCREW,#6-32 X .62 LG.HEX SOC. HD.	2.000 EA
HW5100A06	W2420-025 WVY WSHR (WB)	1.000 EA
HW4500A01	1641B(ALEMITE)400 UNIV, GREASE FITT	1.000 EA

Parts List (continued)		
Part Number	Description	Quantity
HW4500A19	1/4-28X1/4 SLOTTED PLUG F/S	1.000 EA
HW4506A02	BREATHER/DRAIN-EXP PROOF-.125-27 NPTF AI	1.000 EA
HW3022E05	.125 DIA X .500 ROLLED SPRING PIN	1.000 EA
07EP1708A10G	FACE MTD ENDPLATE XPFC-GROUP E	1.000 EA
HW1001A38	LOCKWASHER 3/8, ZINC PLT .688 OD, .382 I	4.000 EA
10XN3816K28	3/8-16 X 1.75 HEX HD CAP SCREW, GRADE 5	4.000 EA
HA2009A56	SLINGER, FOR GROUP E MOTORS - 307 BRG.	1.000 EA
80XN0632A10	SET SCREW,#6-32 X .62 LG.HEX SOC. HD.	1.000 EA
10XN2520A32	1/4 X 2 HEX HEAD CAP SCR,GRADE 2	4.000 EA
HW1001A25	LOCKWASHER 1/4, ZINC PLT .493 OD, .255 I	4.000 EA
HW4500A01	1641B(ALEMITE)400 UNIV, GREASE FITT	1.000 EA
HW4500A19	1/4-28X1/4 SLOTTED PLUG F/S	1.000 EA
HW4506A02	BREATHER/DRAIN-EXP PROOF-.125-27 NPTF AI	1.000 EA
HW3022E05	.125 DIA X .500 ROLLED SPRING PIN	1.000 EA
07CB1000A01G	CONDUIT BOX MACH, W/EPOXY GRAY	1.000 EA
10XN3118A16	5/16-18X1 HEX HD CAP	4.000 EA
WD1000B17	T&B CX35TN OR L35P TERMINAL LUG	1.000 EA
11XW1032G06	10-32 X .38, TAPTITE II, HEX WSHR SLTD U	1.000 EA
07CB1502A01G	CONDUIT BOX LID MACH (DUCTILE IRON) GRAY	1.000 EA
84XN2520J16	1/4-20 X 1 SOC HD CAP SCREW	4.000 EA
MG1500Y02	WILKOPON PRIMER YELLOW	0.022 GA
MG1025G29	WILKOFASST, 789.229, DARK CHARCOAL GRAY	0.022 GA
07PA1011	PKG GRP, 07 CAST IRON PK1181	1.000 EA
10XL3808A28	3/8 X 1 3/4" LAG SCREW	2.000 EA

Product Information Packet: CCPX21126T - 10HP,3490//2900RPM,3PH,60HZ,215TCY,XPFC,

HW2501F21	KEY, 5/16 SQ X 2.375	1.000 EA
HA7000A02	KEY RETAINER RING, 1 1/8 DIA, 1 3/8 DIA	1.000 EA
MJ5001A27	32220KN GRAY SEALER *MIN BUY 4 QTS=1GAL	0.001 QT

AC Induction Motor Performance Data

Record # 73682

Typical performance - not guaranteed values

Winding: 07WGY855-R021		Type: 0730M		Enclosure: TEFC	
Nameplate Data			460 V, 60 Hz: High Voltage Connection		
Rated Output (HP)	10//7.5		Full Load Torque	15.1 LB-FT	
Volts	230/460//190/380		Start Configuration	direct on line	
Full Load Amps	23.6/11.8//21.6/11		Breakdown Torque	56.3 LB-FT	
R.P.M.	3490//2900		Pull-up Torque	17.7 LB-FT	
Hz	60//50	Phase	3	Locked-rotor Torque	23.8 LB-FT
NEMA Design Code	B	KVA Code	G	Starting Current	78.5 A
Service Factor (S.F.)	1		No-load Current	3.65 A	
NEMA Nom. Eff.	90.2	Power Factor	87	Line-line Res. @ 25°C	1.05 Ω
Rating - Duty	40C AMB-CONT		Temp. Rise @ Rated Load	63°C	
S.F. Amps			Temp. Rise @ S.F. Load	79°C	
			Locked-rotor Power Factor	33.7	
			Rotor inertia	0.273 lb-ft ²	

Load Characteristics 460 V, 60 Hz, 10 HP

% of Rated Load	25	50	75	100	125	150
Power Factor	60	80	87	90	90	90
Efficiency	88	91.4	91.3	90.5	89.5	88.2
Speed	3576	3551	3525	3497	3465	3429
Line amperes	4.55	6.56	8.97	11.6	14.5	17.7

Performance Graph at 460V, 60Hz, 10.0HP Typical performance - Not guaranteed values

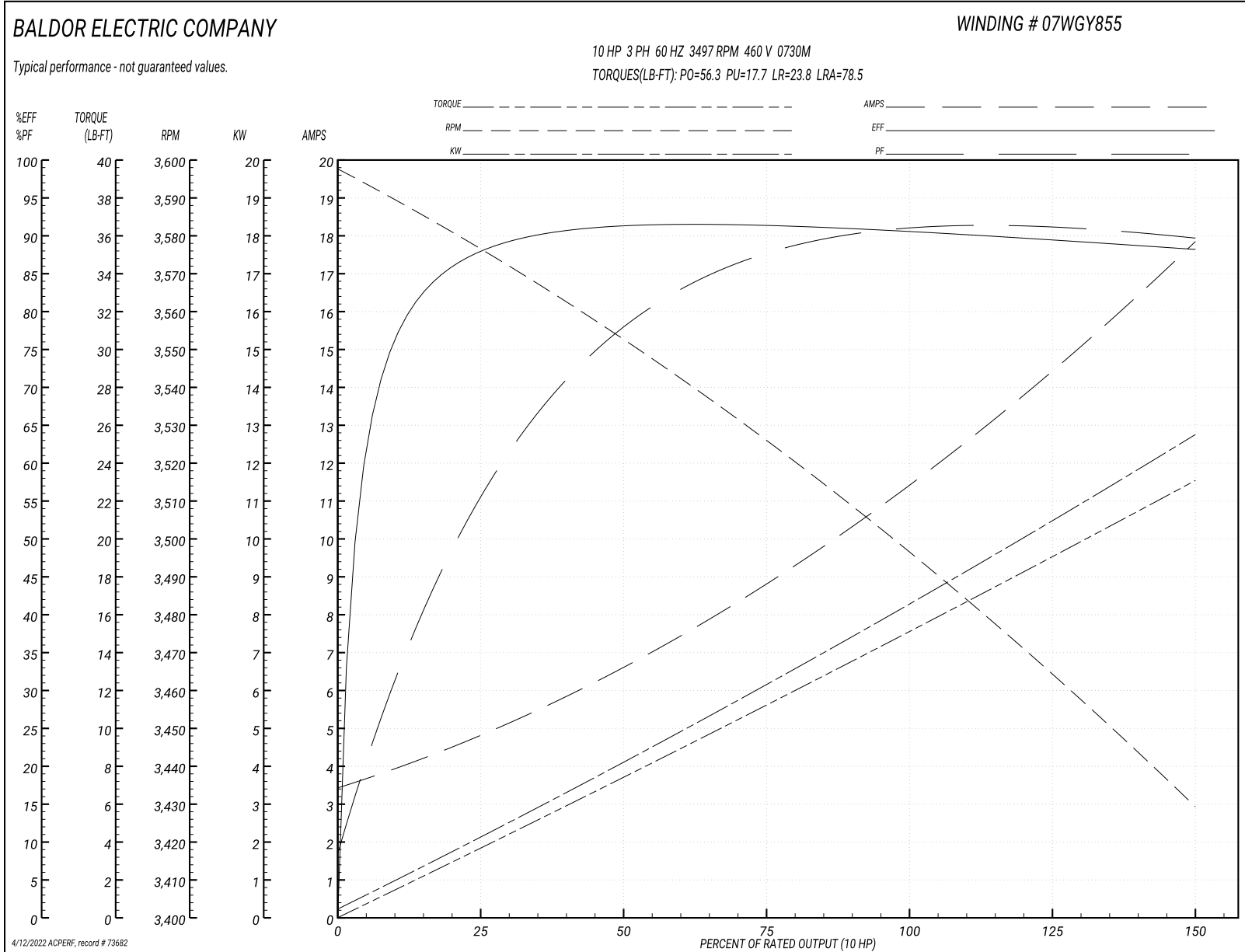

07LY-000-074

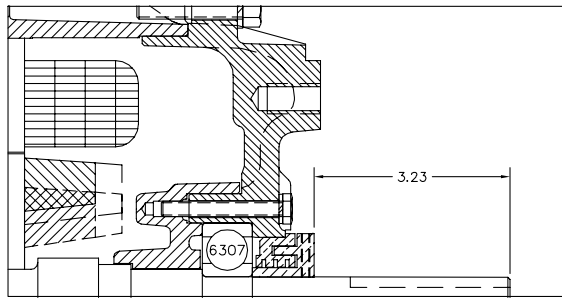
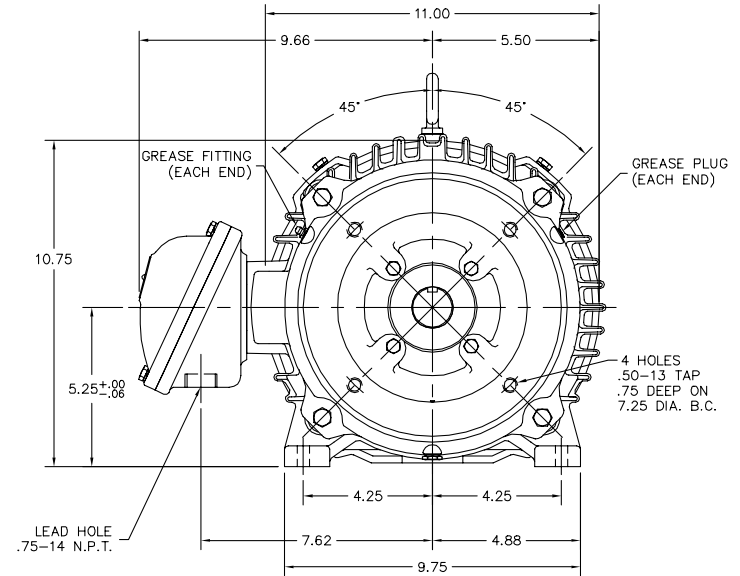
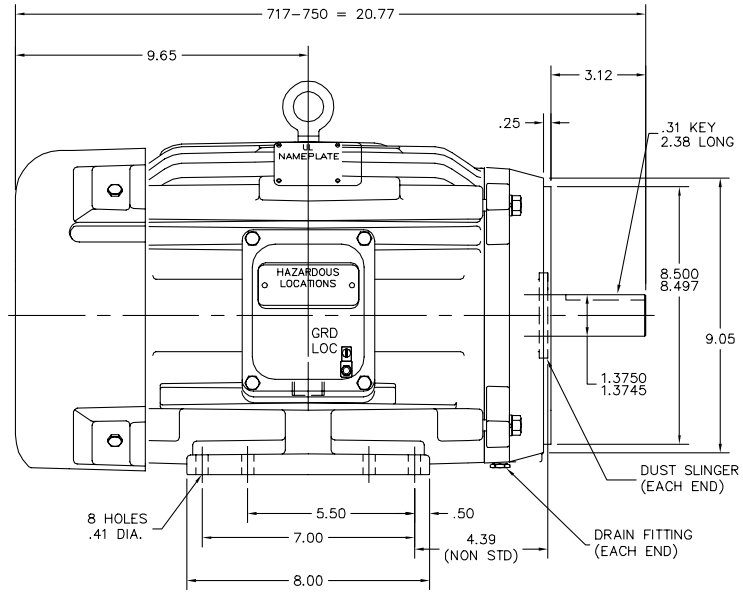

PULLEY END DETAIL

CUSTOMER IS RESPONSIBLE FOR DETERMINING THAT BALDOR'S PRODUCT WILL PERFORM SUITABLY IN THE INTENDED APPLICATION.

REV. DESC: NEW	VERSION: 00	TDR: 000001105221
REV. LTR: -	REVISED: 11:17:54 05/08/2019	BY: ENMICW1
FILE: \AAA\00246\437		
MTL: -		

BALDOR - RELIANCE®

HOR 213-5TCY XPFC CLI GP C&D, CLII GP E,F&G W/CP FEAT,GRSRS

SH 1 of 1

07LY-000-074

CD0005



LOW VOLTAGE
(2Y)

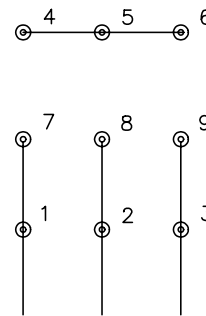

LINE

HIGH VOLTAGE
(1Y)

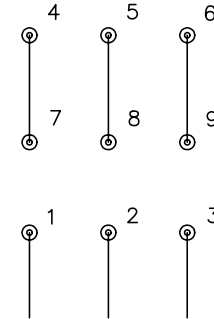

LINE

NOTES:

1. INTERCHANGE ANY TWO LINE LEADS TO REVERSE ROTATION.
2. OPTIONAL THERMOSTATS ARE PROVIDED WHEN SPECIFIED.
3. ACTUAL NUMBER OF INTERNAL PARALLEL CIRCUITS MAY BE A MULTIPLE OF THOSE SHOWN ABOVE.
4. LEAD COLORS ARE OPTIONAL. LEADS MUST ALWAYS BE NUMBERED AS SHOWN.

REV. DESC: REVISE TO SHOW OPTIONAL COLORS			
REV. LTR: E	BY: JLP	REVISED: 01/19/99 10:15	TDR: 0171435
900000		FILE: AAA00005140	MDL: -
		MTL: -	

BALDOR ELECTRIC Co.

3PH, DV, 9 LEADS

CD0005

Marketing maintained PDF of MN416:

<http://www.baldor.com/support/Literature/Load.ashx/MN416?ManNumber=MN416>