

BALDOR® • RELIANCE 

Product Information Packet

CCPX25766T

7.5HP, 1180//980RPM, 3PH, 60HZ, 254TC, XPFC, F

Part Detail							
Revision:	F	Status:	PRD/A	Change #:		Proprietary:	No
Type:	AC	Elec. Spec:	09WGT118	CD Diagram:	CD0005	Mfg Plant:	
Mech. Spec:		Layout:	09LY-000-321	Poles:	06	Created Date:	04-20-2019
Base:		Eff. Date:	06-29-2021	Leads:	9#12		

Specs			
Catalog Number:	CCPX25766T	Duty Rating:	CONT
Enclosure:	XPFC	Electrically Isolated Bearing:	Not Electrically Isolated
Frame:	254TC	Enclosure Modification:	Severe Duty Features
Frame Material:	Iron	Feedback Device:	NO FEEDBACK
Output @ Frequency:	7.500 HP @ 60 HZ	Heater Indicator:	No Heater
	5.000 HP @ 50 HZ	Insulation Class:	F
Synchronous Speed @ Frequency:	1200 RPM @ 60 HZ	Inverter Code:	Inverter Duty
Voltage @ Frequency:	190.0 V @ 50 HZ	IP Rating:	IP55
	230.0 V @ 60 HZ	KVA Code:	J
	380.0 V @ 50 HZ	Lifting Lugs:	Standard Lifting Lugs
	460.0 V @ 60 HZ	Locked Bearing Indicator:	Locked Bearing
XP Class and Group:	CLI GP C,D; CLII GP E,F,G	Motor Lead Termination:	Flying Leads
XP Division:	Division I	Motor Type:	0954M
Agency Approvals:	UR	Mounting Arrangement:	F1
	CSA EEV	Power Factor:	70
	CSA	Product Family:	Chemical Process Features
Auxillary Box:	No Auxillary Box	Pulley Face Code:	C-Face
Auxillary Box Lead Termination:	None	Rodent Screen:	None

Base Indicator:	Rigid	RoHS Status:	ROHS NON-COMPLIANT
Bearing Grease Type:	Polyrex EM (-20F +300F)	Shaft Ground Indicator:	No Shaft Grounding
Blower:	None	Shaft Rotation:	Reversible
Constant Torque Speed Range:	6	Speed Code:	Single Speed
Current @ Voltage:	9.600 A @ 380.0 V	Motor Standards:	NEMA
	23.000 A @ 208.0 V	Starting Method:	Direct on line
	22.000 A @ 230.0 V	Thermal Device - Bearing:	None
	19.200 A @ 190.0 V	Thermal Device - Winding:	Normally Closed Thermostat
	11.000 A @ 460.0 V	Vibration Sensor Indicator:	No Vibration Sensor
Design Code:	A	Winding Thermal 1:	None
Drip Cover:	No Drip Cover	Winding Thermal 2:	None
		XP Temp Code:	T3C

Nameplate NP2033XPSLEV											
NO.						CC	010A				
S/N						TEMP CODE	T3C				
SPEC.	09-0000-1331					INV.TYPE	PWM				
CAT.NO.	CCPX25766T					C HP FR	60		C HP TO	90	
HP	7.5//5					CT HZ FROM	6		CT HZ TO	60	
VOLTS	230/460//190/380					VT HZ FROM	6		VT HZ TO	60	
AMPS	22/11//19.2/9.6					MAG CUR					
RPM	1180//980					MX RPM	1800				
HZ	60//50		PH	3		CL	F		NOM.EFF.	91	
SER.F.	1.00		DES	A		SL HZ	1		WK2	4.34	
FRAME	254TC		RATING	40C AMB-CONT							
BLANK	55C AMB @ 1.0 SF, 60C RISE										
	1.15SF ON SINEWAVE					NEMA MG-1 PT.5,IP55					

Parts List		
Part Number	Description	Quantity
SA368686	SA 09-0000-1331	1.000 EA
RA358206	RA 09-0000-1331	1.000 EA
LB1115N	LABEL,LIFTING DEVICE (ON ROLLS)	1.000 EA
LC0005E01	SPL CONN.DIA./WARN.LABEL(LC0005/LB1119)	1.000 EA
NP2033XPSLEV	SS XP INV UL CSA-EEV CC CL-I GP-C&D	1.000 EA
85XU0407S04	4X1/4 U DRIVE PIN STAINLESS	2.000 EA
85XU0407S04	4X1/4 U DRIVE PIN STAINLESS	4.000 EA
MN416A01	TAG-INSTAL-MAINT no wire (2100/bx) 4/22	1.000 EA
LB1081Z	ALUM XP CAUTION LABEL (ZK PLANT ONLY-	1.000 EA
HW3201A01	1/2-13 EYEBOLT	1.000 EA
HW1002A63	WASHER, 5/8 HI-COLLAR SPRICKWASHER	1.000 EA
09FH1004A48P	FAN COVER, MACH, W/GRSR, RLF & DRN HOLE	1.000 EA
HW1001A25	LOCKWASHER 1/4, ZINC PLT .493 OD, .255 I	3.000 EA
10XN2520K14	1/4-20 X .88 HEX GRD 5 (20001)	3.000 EA
LD7020D09	LEAD SET, 12AWG, 9 LEAD, 20" LONG LEADS	1.000 EA
09FN3001D01SP	EXTERNAL FAN, PLASTIC (COMES W/SCREW FRO	1.000 EA
HW2500A25	WOODRUFF KEY USA #1008 #BLOW CARBON STEE	1.000 EA
MJ1000A02	GREASE, MOBIL POLYREX EM - 124047	0.080 LB
09EP1700A70PP15	FREP, MACH FOR GROUP C & GROUP E MTRS	1.000 EA
10XN3816K28	3/8-16 X 1.75 HEX HD CAP SCREW, GRADE 5	4.000 EA
HW1001A38	LOCKWASHER 3/8, ZINC PLT .688 OD, .382 I	4.000 EA
HA2009A39	SLINGER FOR GROUP E MTRS - 208 BRG.	1.000 EA
80XN0632A10	SET SCREW,#6-32 X .62 LG.HEX SOC. HD.	2.000 EA
HW5100A08	W3118-035 WVY WSHR (WB)	1.000 EA

Parts List (continued)		
Part Number	Description	Quantity
HA4017A03	.125 X 1.75 GREASE EXT (F/S)	1.000 EA
HA4017A08	.125X3.50 GREASER EXTEN.	1.000 EA
HW4019A01	PIPE COUPLING 1/8 NPT,STEEL,ZINC COATING	1.000 EA
HA4051A00	PLASTIC CAP FOR GREASE FITTING	1.000 EA
HW4500A21	1618BALEMITE FITTING 825 UNIVERSAL	1.000 EA
HW4500A20	1/8NPT SL PIPE PLUG	1.000 EA
HW4505A02	BREATHER/DRAIN-EXP PROOF-.250-18 PTF AIS	1.000 EA
HW3023E06	.125 X .625 SPIRAL SPRING PIN	1.000 EA
09EP1708A56P	FACE MTD. EP, MACH X-PROOF GP.E W/EPOXY	1.000 EA
HW1001A38	LOCKWASHER 3/8, ZINC PLT .688 OD, .382 I	4.000 EA
10XN3816K28	3/8-16 X 1.75 HEX HD CAP SCREW, GRADE 5	4.000 EA
HA2009A38	SLINGER FOR GROUP E MTRS - 309 BRG.	1.000 EA
80XN0632A10	SET SCREW,#6-32 X .62 LG.HEX SOC. HD.	2.000 EA
10XN2520K36	1/4-20 X 2.25" HX HD SCRWGRADE 5, ZINC P	4.000 EA
HA4051A00	PLASTIC CAP FOR GREASE FITTING	1.000 EA
HW4500A03	GREASE FITTING, .125 NPT 1610(ALEMITE) 8	1.000 EA
HW4500A20	1/8NPT SL PIPE PLUG	1.000 EA
HW4505A02	BREATHER/DRAIN-EXP PROOF-.250-18 PTF AIS	1.000 EA
HW3023E06	.125 X .625 SPIRAL SPRING PIN	1.000 EA
09CB1003A01P	KOBX, MACH 1.25 NPT GROUP C MTRS PRIMED	1.000 EA
10XN3118K24	5/16-18 X 1.50" HEX HD, GRADE 5	4.000 EA
HW1001A31	LOCKWASHER 5/16, ZINC PLT.591 OD, .319 I	4.000 EA
WD1000B25	GND LUG, BURNDY L125HP OR T&B L125HP-BB	1.000 EA
10XN3118K12	5/16-18 X .75 GRADE 5, ZINC PLATED	1.000 EA

Product Information Packet: CCPX25766T - 7.5HP,1180//980RPM,3PH,60HZ,254TC,XPFC,F

HW1001A31	LOCKWASHER 5/16, ZINC PLT.591 OD, .319 I	1.000 EA
09CB1502A01P	CONDUIT BOX LID MACH. GROUP C MTRS W/EP	1.000 EA
84XN5013J24	1/2-13 X 1-1/2 HEX SOCKET HD CAP SCREW	6.000 EA
HW1001A50	LOCKWASHER 1/2, ZINC PLT, .879 OD, .509 I	6.000 EA
MG1025G29	WILKOFAS, 789.229, DARK CHARCOAL GRAY	0.070 GA
40PA1005	PACKAGING GROUP, 09 STD	1.000 EA
HW2501G25	KEY, 3/8 SQ X 2.875	1.000 EA
MJ5000A09	EFI KIT #1578 (400 ML CARTRIDGE OF EFI	0.031 EA
MJ5001A27	32220KN GRAY SEALER *MIN BUY 4 QTS=1GAL	0.001 QT

AC Induction Motor Performance Data

Record # 57230

Typical performance - not guaranteed values

Winding: 09WGT118-R011			Type: 0954M	Enclosure: XPFC	
Nameplate Data			460 V, 60 Hz: High Voltage Connection		
Rated Output (HP)	7.5		Full Load Torque	33.3 LB-FT	
Volts	230/460		Start Configuration	direct on line	
Full Load Amps	22/11		Breakdown Torque	106 LB-FT	
R.P.M.	1180		Pull-up Torque	41.4 LB-FT	
Hz	60 Phase	3	Locked-rotor Torque	62.8 LB-FT	
NEMA Design Code	A	KVA Code	J	Starting Current	75.7 A
Service Factor (S.F.)	1		No-load Current	5.97 A	
NEMA Nom. Eff.	91	Power Factor	70	Line-line Res. @ 25°C	0.895 Ω
Rating - Duty	40C AMB-CONT		Temp. Rise @ Rated Load	41°C	
			Locked-rotor Power Factor	25.8	
			Rotor inertia	4.34 LB-FT ²	

Load Characteristics 460 V, 60 Hz, 7.5 HP

% of Rated Load	25	50	75	100	125	150
Power Factor	34	53	64	70	74	75
Efficiency	81.3	88	89.6	89.7	89.4	88.3
Speed	1196	1192	1187	1183	1177	1171
Line amperes	6.46	7.57	9.19	11.2	13.3	15.9

Performance Graph at 460V, 60Hz, 7.5HP Typical performance - Not guaranteed values

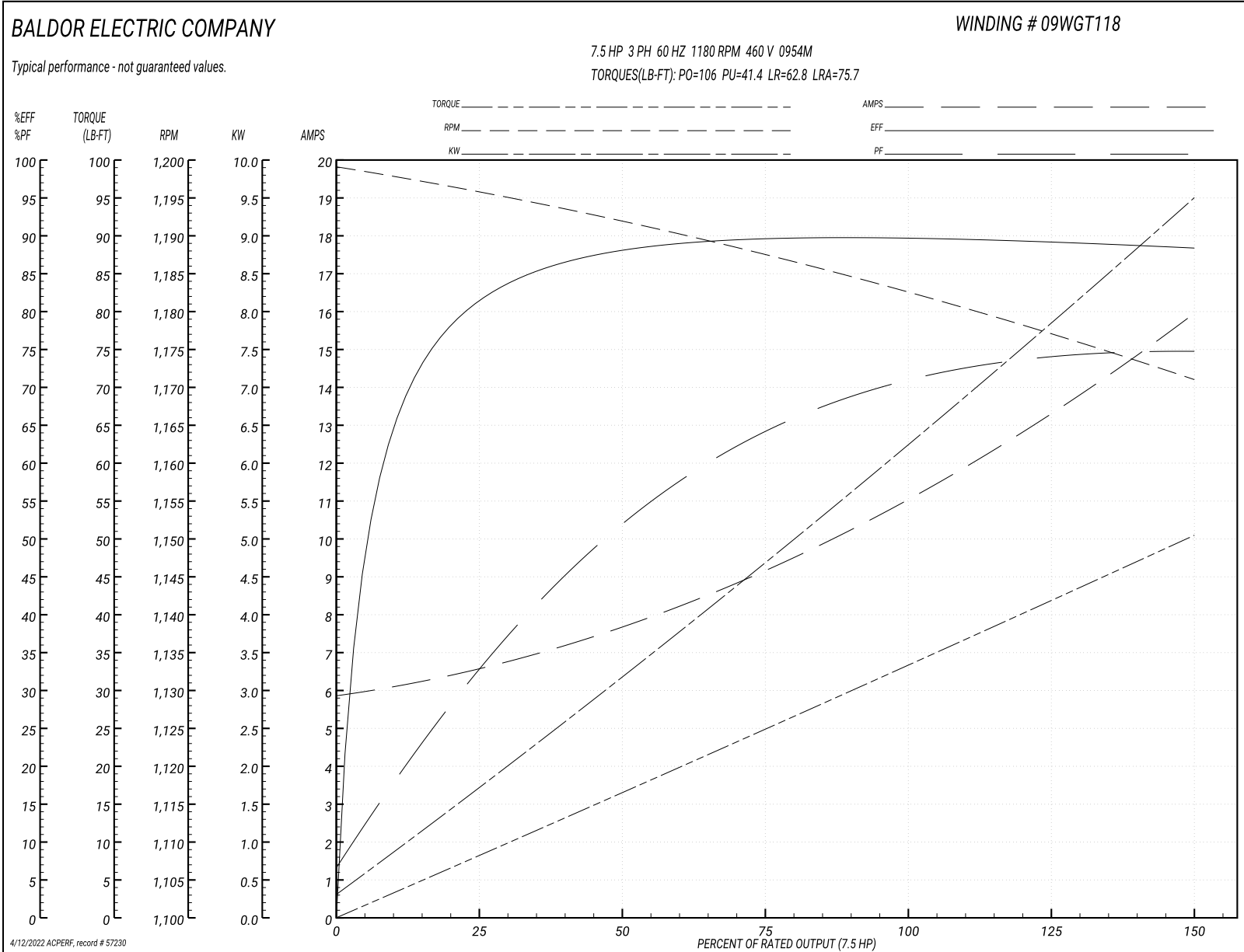

AC Induction Motor Performance Data

Record # 75705

Typical performance - not guaranteed values

Winding: 09WGT118-R007		Type: 0954M	Enclosure: XPFC		
Nameplate Data			380 V, 50 Hz: High Voltage Connection		
Rated Output (HP)	7.5//5		Full Load Torque	26.49 LB-FT	
Volts	230/460//190/380		Start Configuration	direct on line	
Full Load Amps	22/11//19.2/9.6		Breakdown Torque	109 LB-FT	
R.P.M.	1180//980		Pull-up Torque	43.5 LB-FT	
Hz	60//50	Phase	3	Locked-rotor Torque	60.46 LB-FT
NEMA Design Code	A	KVA Code	J	Starting Current	73.36 A
Service Factor (S.F.)	1		No-load Current	6 A	
NEMA Nom. Eff.	91	Power Factor	70	Line-line Res. @ 25°C	0.895 Ω
Rating - Duty	40C AMB-CONT		Temp. Rise @ Rated Load	28°C	
S.F. Amps			Temp. Rise @ S.F. Load	34°C	
			Locked-rotor Power Factor	28.9	
			Rotor inertia	4.34 LB-FT ²	

Load Characteristics 380 V, 50 Hz, 5 HP

% of Rated Load	25	50	75	100	125	150
Power Factor	28	46	58	65	71	74
Efficiency	81.2	87.9	90.1	90.6	90.3	89.6
Speed	997	994	990	987	983	979
Line amperes	6.29	7.06	8.13	9.52	11.08	12.87

Performance Graph at 380V, 50Hz, 5.0HP Typical performance - Not guaranteed values

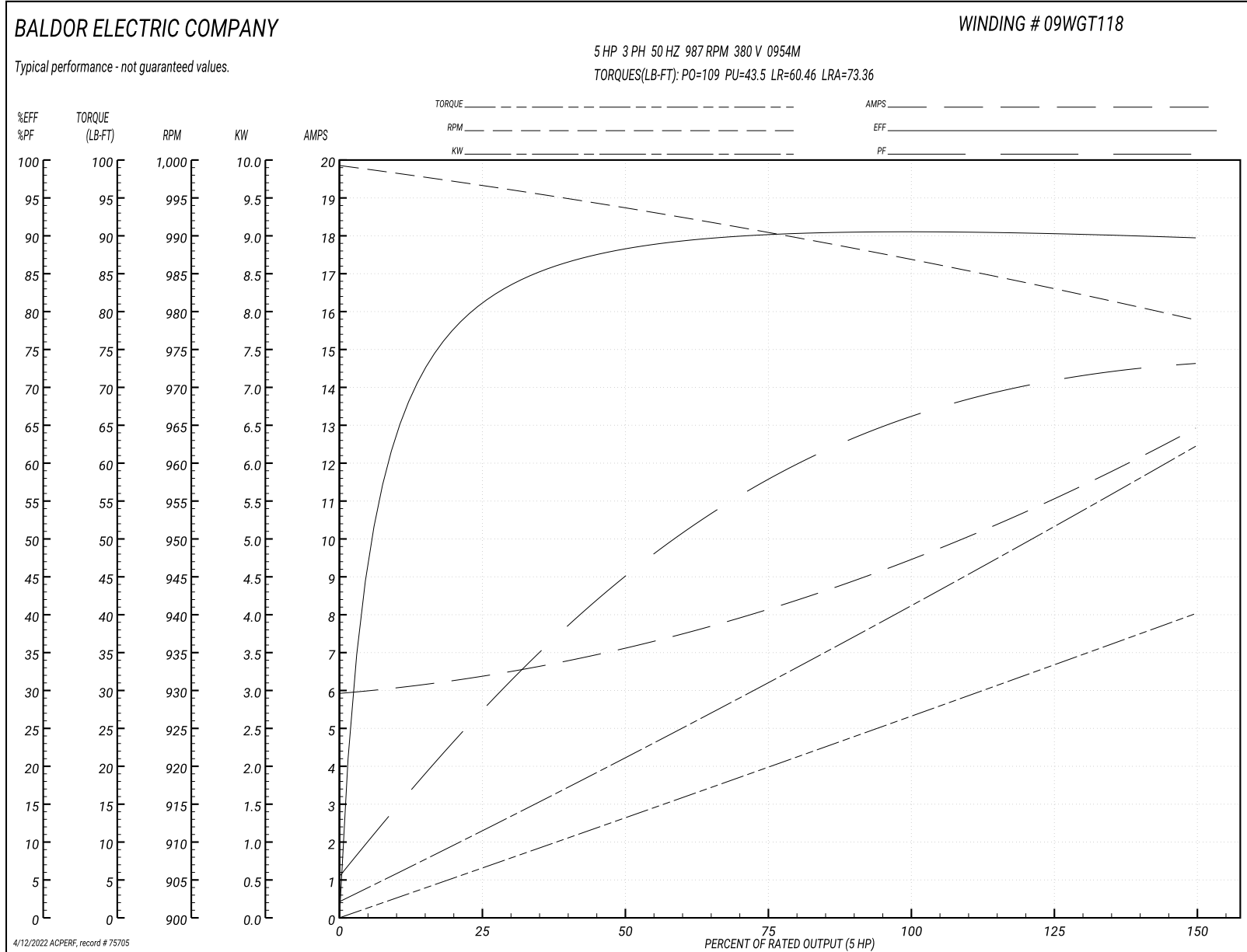

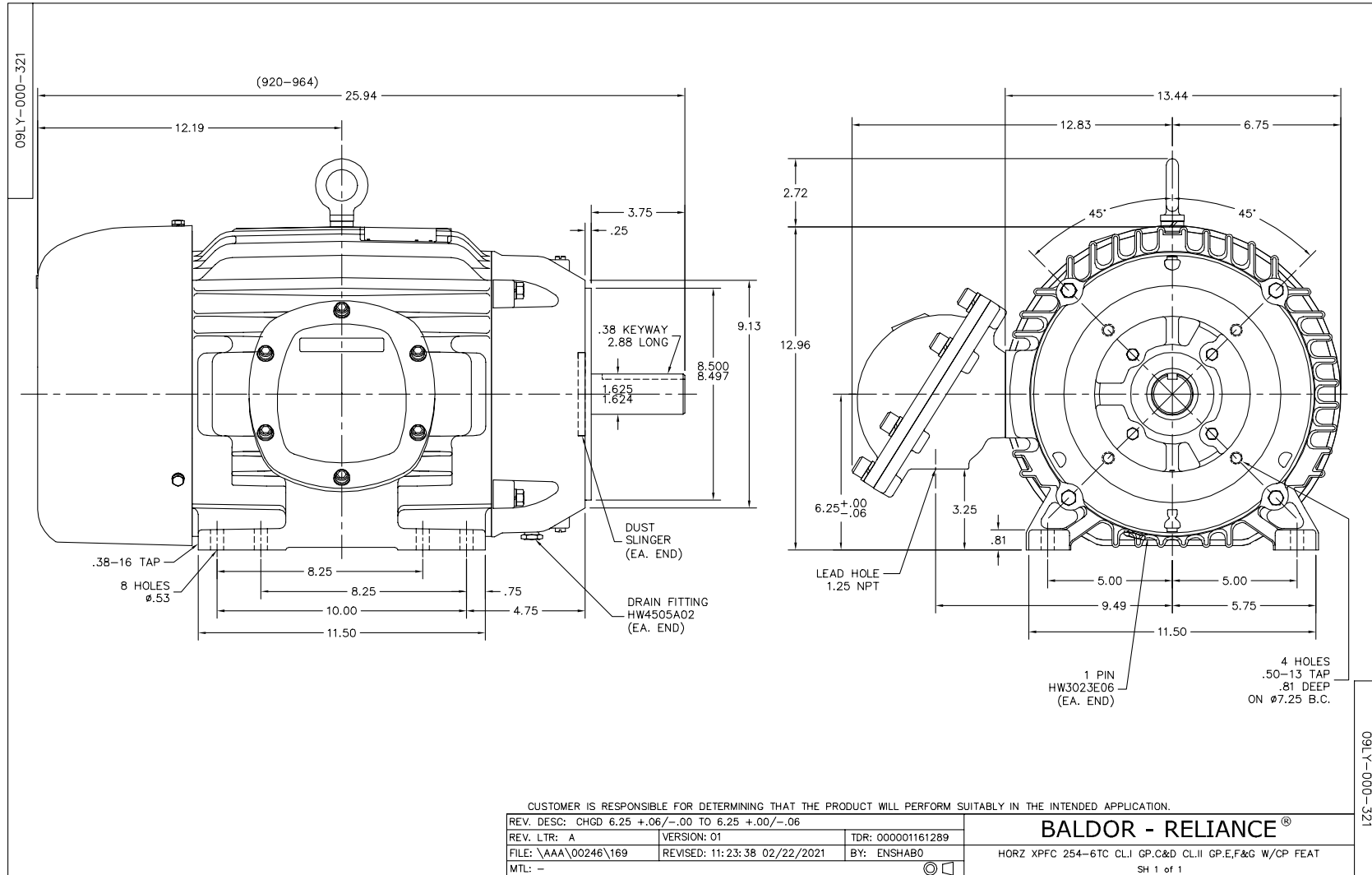

CD0005

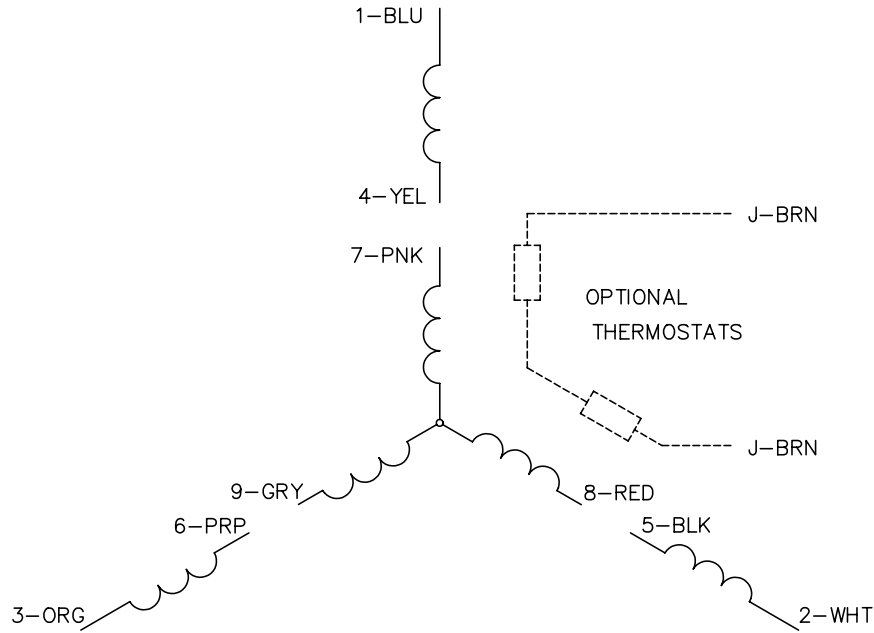

LOW VOLTAGE
(2Y)

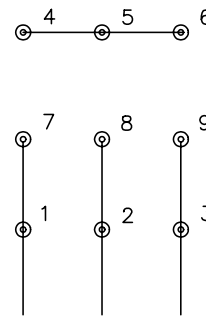

LINE

HIGH VOLTAGE
(1Y)

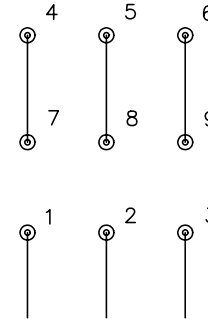

LINE

NOTES:

1. INTERCHANGE ANY TWO LINE LEADS TO REVERSE ROTATION.
2. OPTIONAL THERMOSTATS ARE PROVIDED WHEN SPECIFIED.
3. ACTUAL NUMBER OF INTERNAL PARALLEL CIRCUITS MAY BE A MULTIPLE OF THOSE SHOWN ABOVE.
4. LEAD COLORS ARE OPTIONAL. LEADS MUST ALWAYS BE NUMBERED AS SHOWN.

REV. DESC: REVISE TO SHOW OPTIONAL COLORS			
REV. LTR: E	BY: JLP	REVISED: 01/19/99 10:15	TDR: 0171435
900000		FILE: AAA00005140	MDL: -
		MTL: -	

BALDOR ELECTRIC Co.

3PH, DV, 9 LEADS

CD0005

Marketing maintained PDF of MN416:

<http://www.baldor.com/support/Literature/Load.ashx/MN416?ManNumber=MN416>