

DATE: January 26, 2018
 CATALOG NO. CDP0506

OUTLINE DIMENSIONS
 3-PHASE INDUCTION MOTOR

MOTOR TYPE: AEHHGD
 FRAME NO. 365T

Pole	HP	kW	Hz	VOLT	r/min
6	50	37.3	60	230/460	1200

Ins	Rating	Dimension in	Approx Weight	Bearings
F	CONT.	inches	1040 LBS.	DE: 6313 NDE: NU213

Totally Enclosed Fan-Cooled Type, Squirrel-Cage Rotor.

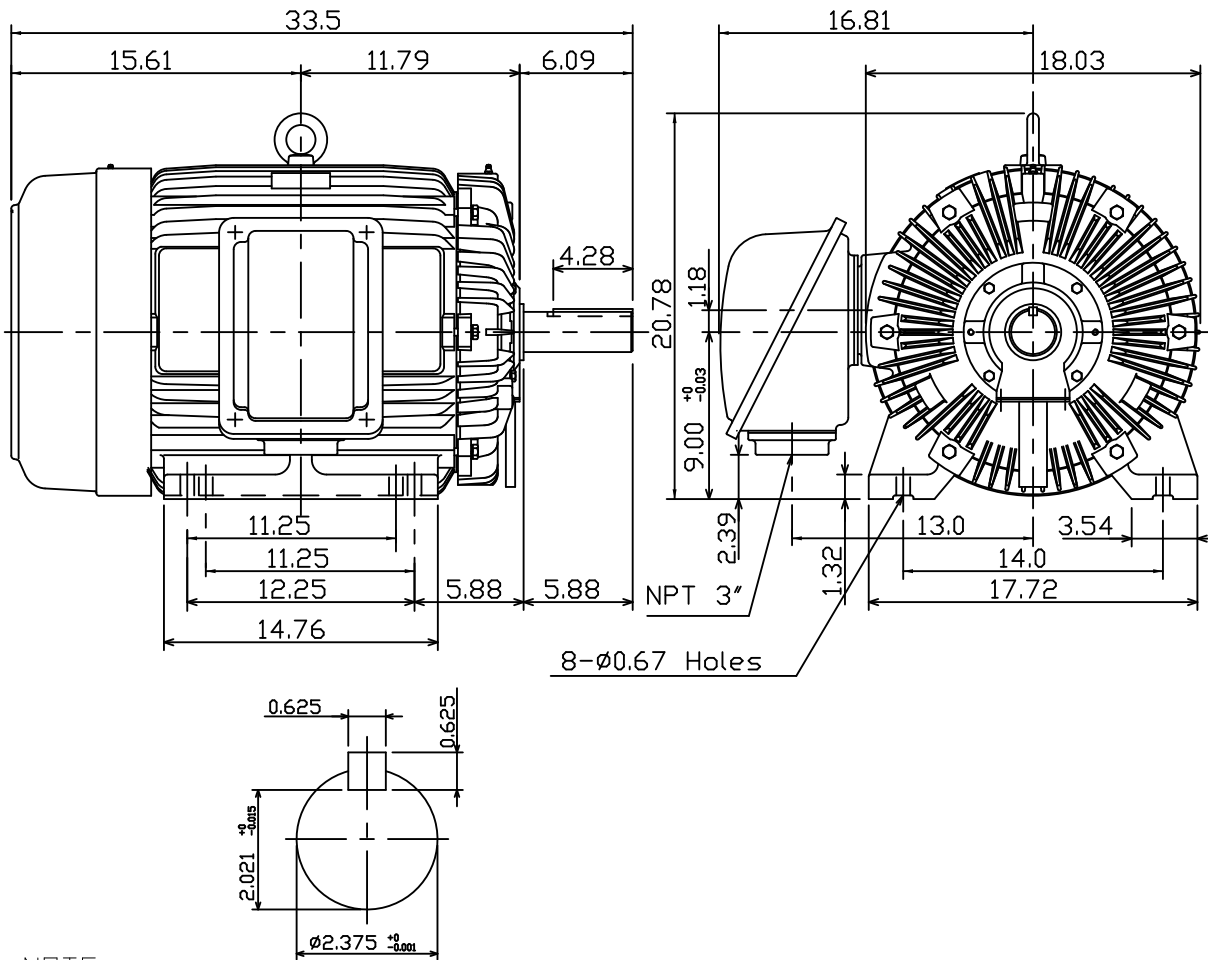

NOTE:

1. ENCLOSURE: IP55
2. SHAFT MATERIAL: SCM440 Q&T (AISI 4140 EQUIV)
3. WITH THERMISTOR: PTC 140°C x 3PCS
 WIRED IN MAIN TERMINAL BOX

--	--	--	--	--	--	--	--

				DWG NO. 31049J361680			
DWG.	C.COOK	02-01-18					

TECO Westinghouse

ISSUED 4/4/2019	PERFORMANCE DATA 3-PHASE INDUCTION MOTOR	ENCLOSURE TEFC
TYPE AEHHGD		CATALOG# CDP0506R

NAMEPLATE INFORMATION

OUTPUT		POLE	FRAME SIZE	VOLTAGE	HZ	RATED AMBIENT	INS. CLASS	NEMA DESIGN	TIME RATING	SERVICE FACTOR
HP	KW									
50	37.3	6	365T	230/460	60	40°C	F	C	CONT.	1.15

VARIABLE FREQUENCY DRIVE SERVICE

VARIABLE TORQUE				OHMS/PHASE EQUIVALENT WYE CIRCUIT (AT RATED OPERATING TEMPERATURE 25°C)				
HZ	HP	RPM	TORQUE (lb-ft)	R1	R2	X1	X2	X _m
3~60	0.0063~50	60~1200	0.551~222.5	0.0502	0.1436	0.3901	0.6604	12.317

CONSTANT TORQUE				CONSTANT HORSEPOWER			
HZ	HP	RPM	TORQUE (lb-ft)	HZ	HP	RPM	TORQUE (lb-ft)
6~60	5~50	120~1200	222.5	60~90	50	1200~1800	222.5~148.3

TYPICAL PERFORMANCE

FULL LOAD RPM	EFFICIENCY				POWER FACTOR			SOUND PRESSURE LEVEL @ 3 FT Db(A)
	FULL LOAD		3/4 LOAD %	1/2 LOAD %	FULL LOAD %	3/4 LOAD %	1/2 LOAD %	
	MIN.%	NOM.%						
1180	93	94.1	94.5	93.6	86	83	75.5	75

CURRENTS						NEMA KVA CODE LETTER	SAFE STALL TIME IN SECONDS	
NO LOAD		FULL LOAD		LOCKED ROTOR			COLD	HOT
AT 230 VOLT	AT 460 VOLT	AT 230 VOLT	AT 460 VOLT	AT 230 VOLT	AT 460 VOLT			
41.8	20.9	115.6	57.8	726.0	363.0	G	29	20

TORQUE				INERTIA			ACCEL TIME (DOL)		ALLOWABLE STARTS PER HOUR	
FULL LOAD (lb-ft)	LOCKED ROTOR %FLT	PULL UP %FLT	BREAK DOWN %FLT	ROTOR WR ² (lb-ft ²)	NEMA LOAD WK ² (lb-ft ²)	MAX ALLOWABLE WK ² (lb-ft ²)	NEMA LOAD WK ² Sec	MAX ALLOWABLE WK ² Sec	COLD	HOT
222.50	225	170	240	21.38	620	1385	5.22	11.44	2	1

APPROVED:	K. Lo	DRAWING NO.	31057CDP0506R	REVISION:	1
-----------	--------------	-------------	----------------------	-----------	----------

DATE:
December 28, 2010

CONNECTION DIAGRAM

CATALOG NO.:
CDP0506

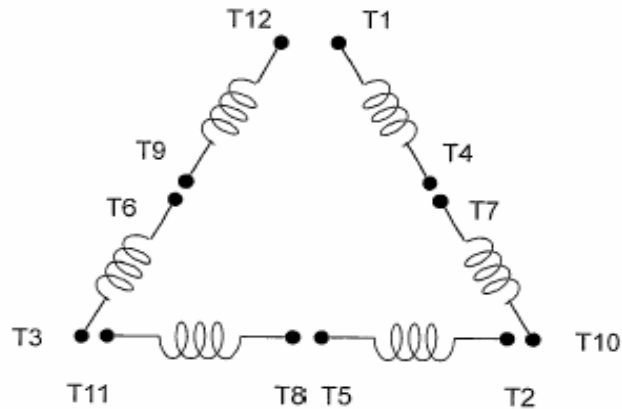

SCHEMATIC - Δ / Y CONNECTION

ACROSS THE LINE CONNECTION

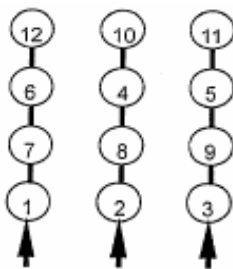

LINE
230 VOLT CONNECTION



LINE
460 VOLT CONNECTION

***CONTACT TWMC IF YOU HAVE ANY QUESTIONS
REGARDING THE MOTOR CONNECTION.**

PH: 1-800-873-8326