

DATE: January 26, 2018
 CATALOG NO CDP0508R

OUTLINE DIMENSIONS
 3-PHASE INDUCTION MOTOR

MOTOR TYPE: AEHHGD
 FRAME NO. 404T

Pole	HP	kW	Hz	VOLT	r/min
8	50	37.3	60	230/460	900
Ins	Rating	Dimension in	Approx Weight	Bearings	
F	CONT.	inches	868 LBS.	DE: NU317	NDE: 6313

Totally Enclosed Fan Cooled Type.Squirrel-cage Rotor.

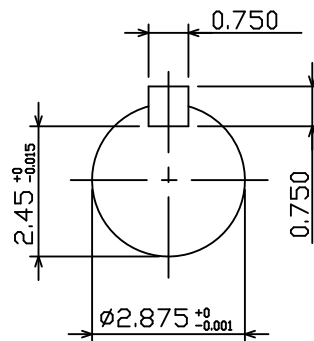
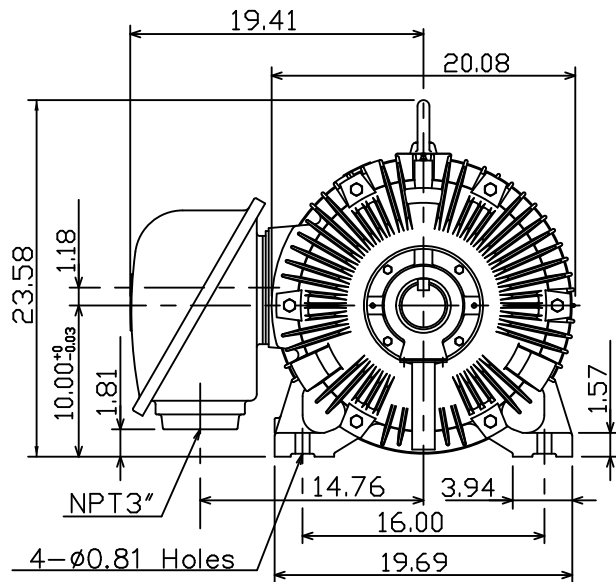
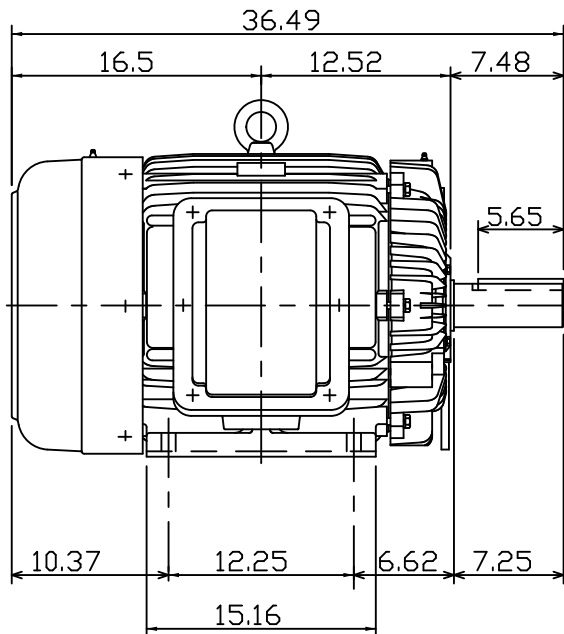

NOTE:

1. ENCLOSURE: IP55
2. SHAFT MATERIAL: SCM440 Q&T (AISI 4140 EQUIV)
3. WITH THERMISTOR: PTC 140°C × 3PCS WIRED IN MAIN TERMINAL BOX



DWG.	C.COOK	02 01 18
------	--------	----------



DWG NO.
 31049M633410

ISSUED 1-Apr-16	PERFORMANCE DATA 3-PHASE SQUIRREL CAGE HIGH EFFICIENCY INDUCTION MOTORS	MODEL AEHHGD
REVISED 13-Feb-17		



ee C C O O 2 A

TEFC, NEMA T-FRAME, DESIGN - C,
CLASS F, 40°C AMBIENT, CONTINUOUS DUTY,
S.F. 1.15 460V 60Hz

TYPICAL PERFORMANCE

(460 V)

OUTPUT HP	KW	POLE	FULL LOAD RPM	FRAME SIZE	EFFICIENCY(%)				POWER FACTOR(%)			CURRENT			TORQUE				ROTOR WK ² lb-ft ²	NEMA CODE LETTER
					FULL LOAD		3/4 LOAD	1/2 LOAD	FULL LOAD	3/4 LOAD	1/2 LOAD	FULL LOAD	208V USABLE	LOCKED ROTOR	FULL LOAD	LOCKED ROTOR	PULL UP	BREAK DOWN		
					NOM.	MIN.	NOM.	NOM.	(A)	ON-A	(A)	lb-ft	%FLT	%FLT	%FLT					
1	0.75	4	1745	143T	85.5	82.5	84.0	81.5	73.0	64.5	51.5	1.50	3.32	15	3.009	350	300	410	0.086	N
		6	1150	145T	82.5	80.0	82.5	80.0	65.5	57.0	44.5	1.73	3.83	15	4.566	255	220	300	0.122	N
		8	870	182T	75.5	72.0	72.0	65.0	51.0	43.0	33.0	2.43	5.38	15	6.035	225	190	320	0.239	N
1.5	1.1	4	1730	145T	86.5	84.0	86.5	85.5	78.0	70.0	57.0	2.08	4.60	20	4.552	300	260	360	0.093	M
		6	1175	182T	87.5	85.5	85.5	82.5	60.0	51.0	39.0	2.68	5.92	20	6.703	260	250	400	0.313	M
		8	870	184T	78.5	75.5	76.0	71.0	52.0	44.0	33.0	3.44	7.61	20	9.053	225	190	320	0.330	M
2	1.5	4	1740	145T	86.5	84.0	86.5	84.0	78.0	70.0	57.0	2.78	6.14	25	6.035	285	220	330	0.108	L
		6	1175	184T	88.5	86.5	87.5	85.5	60.0	50.0	38.0	3.53	7.80	25	8.937	250	245	390	0.423	L
		8	865	213T	85.5	82.5	84.0	81.0	68.0	58.0	45.0	3.22	7.12	25	12.14	225	190	280	0.586	L
3	2.2	4	1760	182T	89.5	87.5	89.5	88.5	78.5	72.0	60.0	4.00	8.84	32	8.950	280	225	400	0.367	K
		6	1175	213T	89.5	87.5	89.5	87.5	78.0	70.5	58.5	4.02	8.90	32	13.41	250	180	340	0.918	K
		8	865	215T	85.5	82.5	85.5	83.0	66.0	56.0	45.0	4.98	11.0	32	18.21	245	230	305	0.821	K
5	3.7	4	1755	184T	89.5	87.5	88.5	88.0	82.0	76.0	64.0	6.4	14.1	46	14.96	255	190	320	0.422	J
		6	1175	215T	91.0	89.5	91.0	89.5	78.0	71.0	58.0	6.6	14.6	46	22.34	250	210	380	1.224	J
		8	875	254T	86.5	84.0	85.5	84.0	65.0	56.0	44.0	8.3	18.4	46	30.00	225	210	290	1.660	J
7.5	5.5	4	1755	213T	91.7	90.2	91.0	89.5	86.5	82.0	72.0	8.9	19.6	64	22.44	250	175	270	0.848	H
		6	1170	254T	91.0	89.5	91.0	89.5	80.5	75.0	64.0	9.6	21.2	64	33.66	240	215	270	2.158	H
		8	875	256T	87.5	85.5	87.5	85.5	74.0	66.0	53.0	10.8	24.0	64	45.00	230	190	290	2.872	H
10	7.5	4	1755	215T	91.7	90.2	91.0	91.0	88.0	84.0	75.5	11.6	25.7	81	29.92	280	205	315	1.082	H
		6	1170	256T	91.0	89.5	91.7	90.2	80.5	75.0	64.0	12.8	28.3	81	44.88	230	200	260	2.872	H
		8	885	284T	90.2	88.5	90.2	89.5	73.5	66.0	53.5	14.1	31.2	81	59.33	235	210	280	5.421	H
15	11	4	1765	254T	92.4	91.0	93.0	92.4	88.0	85.0	77.0	17.3	38.2	216	44.62	245	180	290	2.179	G
		6	1175	284T	92.4	91.0	93.0	93.0	83.5	79.5	70.5	18.2	40.3	216	67.03	230	180	260	6.823	G
		8	875	286T	90.2	88.5	90.2	90.2	78.0	73.0	62.0	20.0	44.1	216	90.01	200	170	230	7.961	G
20	15	4	1770	256T	93.0	91.7	93.0	92.4	86.0	84.0	76.0	23.4	51.8	245	59.33	200	165	250	2.871	G
		6	1170	286T	91.7	90.2	92.4	92.4	84.0	81.0	73.0	24.3	53.8	245	89.75	210	160	225	8.340	G
		8	875	324T	91.0	89.5	91.7	91.7	81.0	77.0	68.0	25.4	56.2	245	120.0	200	150	210	10.39	G
25	18.5	4	1765	284T	93.6	92.4	93.6	93.6	86.0	83.0	77.0	29.1	64.3	183	74.37	205	165	250	4.586	G
		6	1170	324T	93.0	91.7	93.6	93.6	83.0	80.0	71.5	30.3	67.1	183	112.2	200	155	220	11.88	G
		8	875	326T	91.0	89.5	91.7	91.7	80.0	76.0	66.0	32.2	71.1	183	150.0	200	170	220	12.37	G
30	22	4	1770	286T	93.6	92.4	93.6	93.6	87.5	85.5	79.5	34.3	75.8	218	88.99	220	170	250	5.274	G
		6	1175	326T	93.0	91.7	93.6	93.6	80.5	78.5	71.0	37.5	83.0	218	134.1	210	180	230	12.37	G
		8	885	364T	93.0	91.7	93.0	92.4	78.0	73.0	61.0	38.7	85.6	218	178.0	210	170	240	17.94	G
40	30	4	1770	324T	94.1	93.0	94.5	94.5	86.0	84.5	78.5	46.3	102	290	118.7	205	170	220	8.624	G
		6	1180	364T	94.1	93.0	94.5	94.1	86.5	84.5	78.0	46.0	102	290	178.0	200	150	220	17.94	G
		8	885	365T	93.0	91.7	93.0	92.4	78.0	73.0	62.0	52	114	290	237.3	210	160	230	19.32	G
50	37	4	1770	326T	94.5	93.6	95.0	95.0	87.0	86.0	80.5	57	126	363	148.3	210	170	220	10.12	G
		6	1180	365T	94.1	93.0	94.5	93.6	86.0	83.0	75.5	58	128	363	222.5	225	170	240	21.39	G
		8	885	404T	93.0	91.7	93.6	93.6	81.0	77.0	68.0	62	137	363	296.6	210	175	230	31.47	G

APPD.	Liau-Shin Hung	21-Feb-17	TECO Electric & Machinery Co., Ltd.	DWG. NO.	31057D62114
CHKD.	Ho-Miuy Te	22-Feb-17		REV. 04	
DWN.	Davis Ting	13-Feb-17		1/6	

DATE
7-26-15

TWMC

CONNECTION DIAGRAM

12 LEAD MOTOR

MODEL
AEEAGD

CATALOG NO.

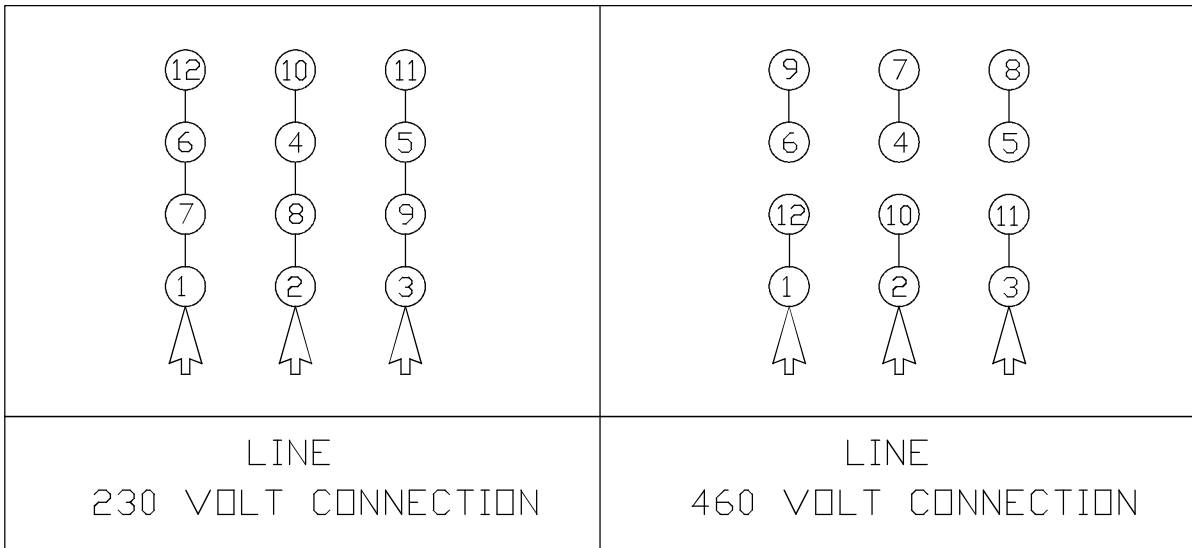
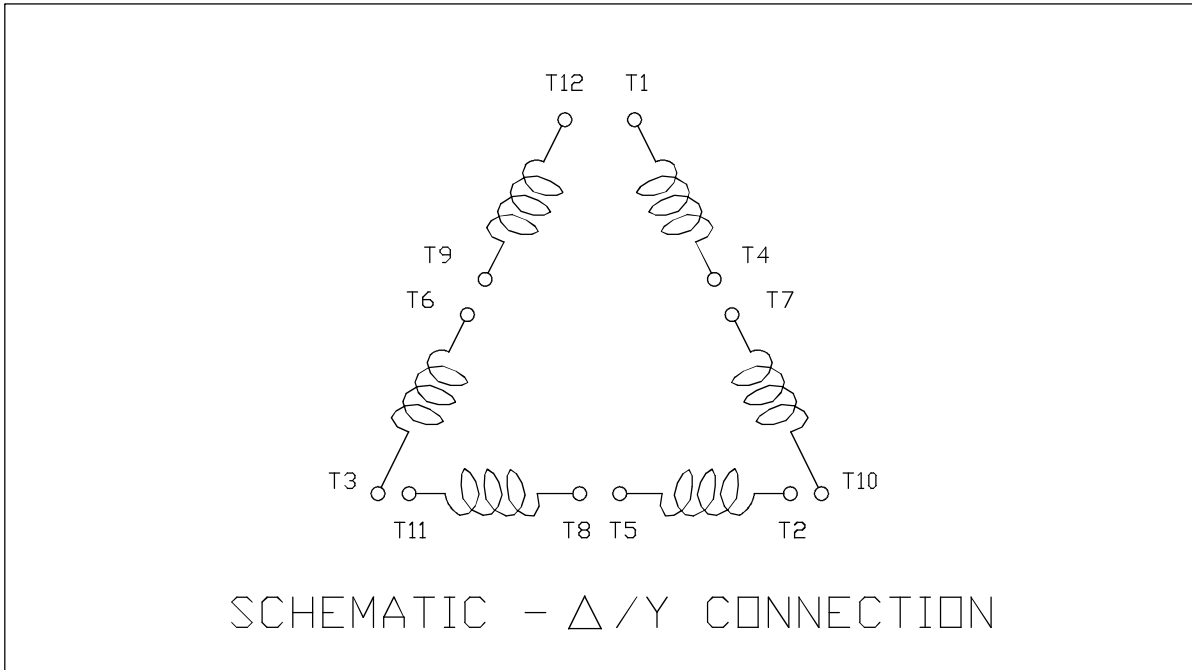

NOTES:

1. SUITABLE FOR WYE START-DELTA RUN CONNECTION
2. CALL TWMC IF YOU HAVE ANY QUESTIONS REGARDING MOTOR CONNECTION
3. CALL OUR CUSTOMER SERVICE LINE: 1-800-USE-TECO (1-800-873-8326)

DWN.	C. RAM	JULY•26•2015
CHKD.		
APPD.		



DWG NO. REV: 00

DAC-1565-W

DATE
7-23-15

SCHMATIC DRAWING
THERMISTOR WIRING DIAGRAM

MODEL
AEEAGD

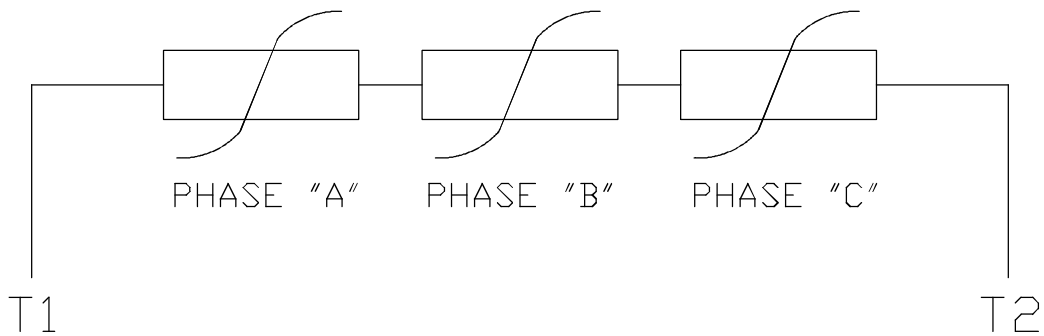

NOTES:

1. PTC THERMISTORS
2. NORMALLY CLOSED RATED AT 140°C
3. 1 PER PHASE (3 PIECES)

DWN.	C. RAM	JULY•23•2015
CHKD.		
APPD.		



DWG NO. REV: 00
3A061H531W