

DATE: January 26, 2018
 CATALOG NO. CDP0754

OUTLINE DIMENSIONS
 3-PHASE INDUCTION MOTOR

MOTOR TYPE: AEHHGD
 FRAME NO. 365T

Pole	HP	kW	Hz	VOLT	r/min
4	75	55.6	60	230/460	1800

Ins	Rating	Dimension in	Approx Weight	Bearings
F	CONT.	inches	1075 LBS.	DE: 6313 NDE: 6213

Totally Enclosed Fan-Cooled Type, Squirrel-Cage Rotor.

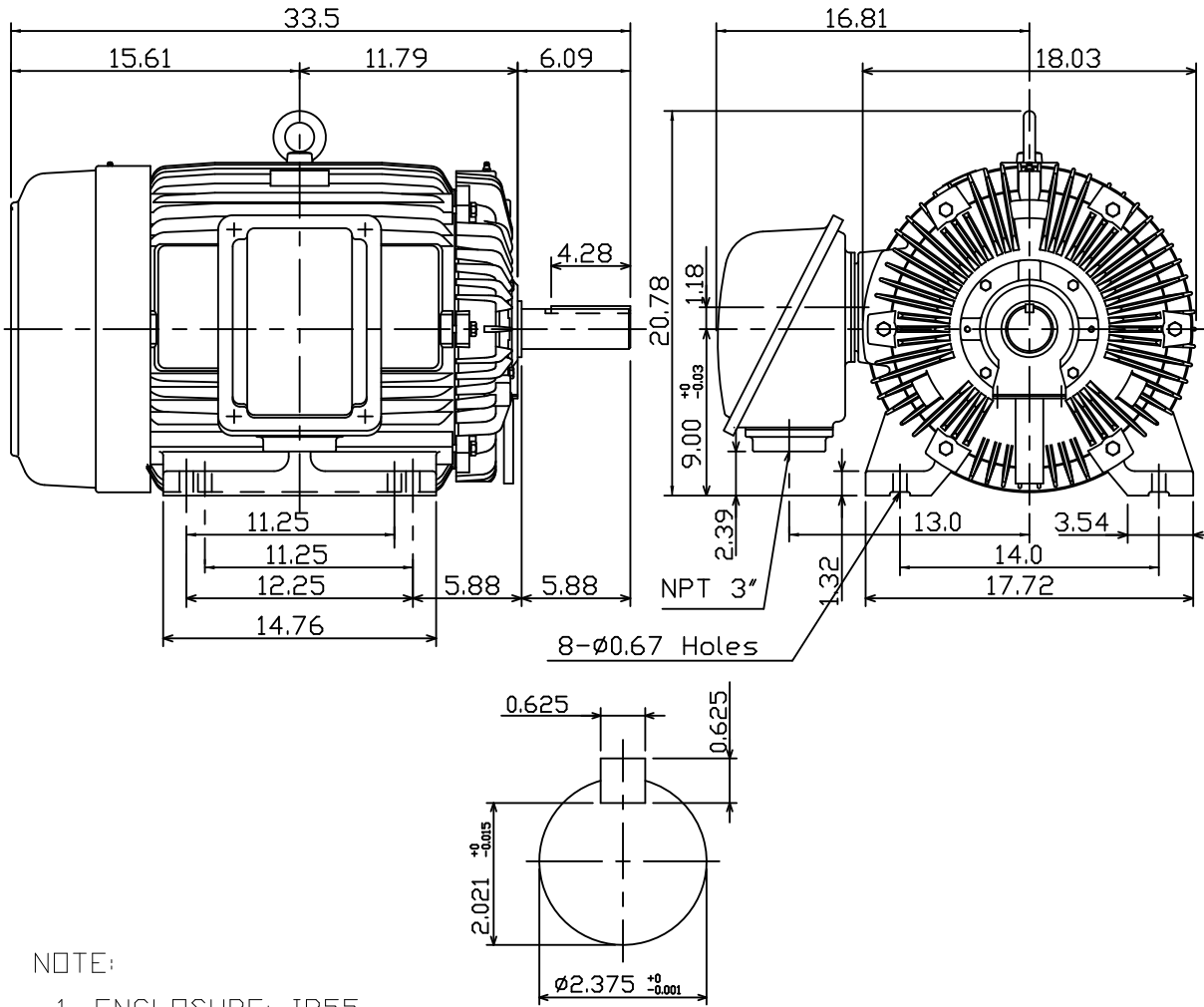

NOTE:

- ENCLOSURE: IP55
- SHAFT MATERIAL: SCM440 Q&T (AISI 4140 EQUIV)
- WITH THERMISTOR: PTC 140°C x 3PCS
WIRED IN MAIN TERMINAL BOX

◇			
---	--	--	--

DWG.	C.COOK	02-01-18	TEC Westinghouse	DWG NO. 31049J361680
------	--------	----------	------------------	-------------------------

TECO Westinghouse

ISSUED 6/25/2018	PERFORMANCE DATA 3-PHASE INDUCTION MOTOR	ENCLOSURE TEFC
TYPE AEHHGD		CATALOG# CDP0754

NAMEPLATE INFORMATION

OUTPUT		POLE	FRAME SIZE	VOLTAGE	HZ	RATED AMBIENT	INS. CLASS	NEMA DESIGN	TIME RATING	SERVICE FACTOR
HP	KW									
75	56.0	4	365T	230/460	60	40°C	F	C	CONT.	1.15

VARIABLE FREQUENCY DRIVE SERVICE

VARIABLE TORQUE				OHMS/PHASE EQUIVALENT WYE CIRCUIT (AT RATED OPERATING TEMPERATURE 25°C)				
HZ	HP	RPM	TORQUE (lb-ft)	R1	R2	X1	X2	X _m
3~60	0.009~75	90~1800	0.525~221.8	0.0296	0.0666	0.2316	0.4277	10.003

CONSTANT TORQUE				CONSTANT HORSEPOWER			
HZ	HP	RPM	TORQUE (lb-ft)	HZ	HP	RPM	TORQUE (lb-ft)
6~60	7.5~75	180~1800	221.8	60~90	75	1800~2700	221.8~147.9

TYPICAL PERFORMANCE

FULL LOAD RPM	EFFICIENCY				POWER FACTOR			SOUND PRESSURE LEVEL @ 3 FT Db(A)
	FULL LOAD		3/4 LOAD %	1/2 LOAD %	FULL LOAD %	3/4 LOAD %	1/2 LOAD %	
	MIN.%	NOM.%						
1775	94.5	95.4	95.4	95	86.5	83.5	75.5	79

CURRENTS									NEMA KVA CODE LETTER	SAFE STALL TIME IN SECONDS	
NO LOAD			FULL LOAD			LOCKED ROTOR				COLD	HOT
AT 208 VOLT	AT 230 VOLT	AT 460 VOLT	AT 208 VOLT	AT 230 VOLT	AT 460 VOLT	AT 208 VOLT	AT 230 VOLT	AT 460 VOLT			
41.10	52.00	26	188.20	170.20	85.10	982.1	1086.0	543	G	17	12

TORQUE				INERTIA			ACCEL TIME (DOL)		ALLOWABLE STARTS PER HOUR	
FULL LOAD (lb-ft)	LOCKED ROTOR %FLT	PULL UP %FLT	BREAK DOWN %FLT	ROTOR WR ² (lb-ft ²)	NEMA LOAD WK ² (lb-ft ²)	MAX ALLOWABLE WK ² (lb-ft ²)	NEMA LOAD WK ² Sec	MAX ALLOWABLE WK ² Sec	COLD	HOT
221.90	200	165	250	14.674	338	618	4.40	7.89	2	1

APPROVED:	M. PRATER	DRAWING NO.	31057CDP0754	REVISION:	0
-----------	------------------	-------------	---------------------	-----------	----------

DATE:
December 28, 2010

CONNECTION DIAGRAM

CATALOG NO.:
CDP0754



SCHEMATIC - Δ / Y CONNECTION

ACROSS THE LINE CONNECTION



LINE
230 VOLT CONNECTION



LINE
460 VOLT CONNECTION

***CONTACT TWMC IF YOU HAVE ANY QUESTIONS
REGARDING THE MOTOR CONNECTION.**

PH: 1-800-873-8326