

DATE:
January 26, 2018
CATALOG NO.
CDP0756

OUTLINE DIMENSIONS
3-PHASE INDUCTION MOTOR

MOTOR TYPE:
AEHHGD
FRAME NO. 405T

Pole	HP	kW	Hz	VOLT	r/min
6	75	55.6	60	230/460	1200
Ins	Rating	Dimension in	Approx Weight	Bearings	
F	CONT.	inches	1317 LBS.	DE: 6317	NDE: 6313

Totally Enclosed Fan Cooled Type.Squirrel-cage Rotor.

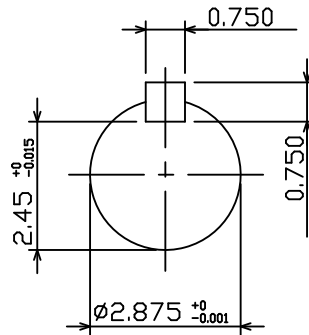
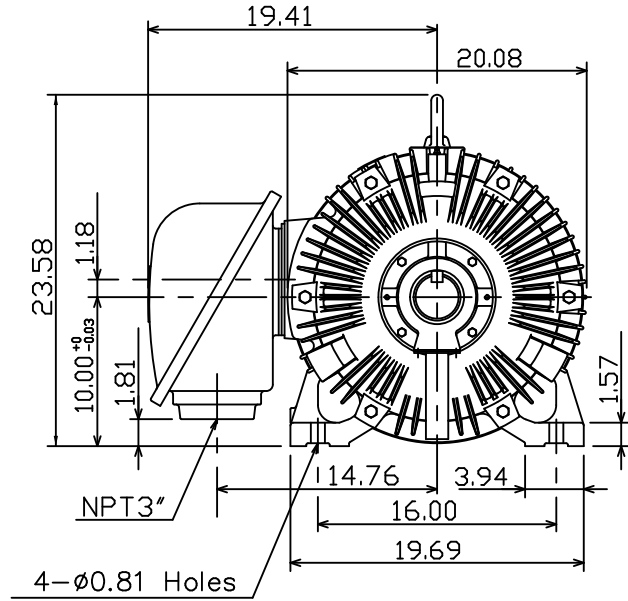
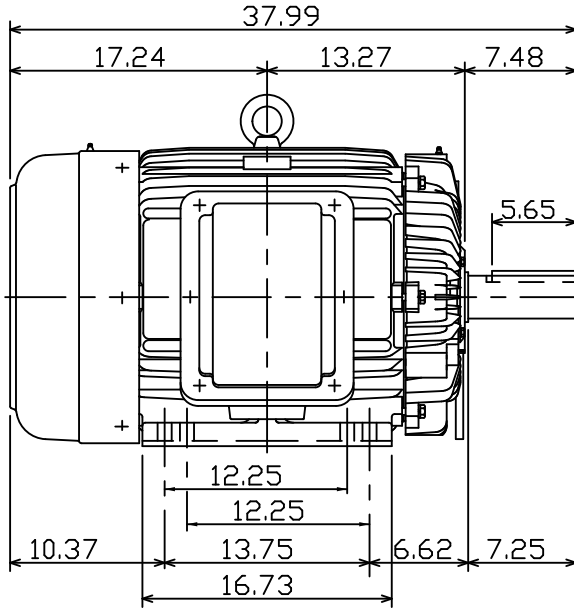

NOTE:

1. ENCLOSURE: IP55
2. SHAFT MATERIAL: SCM440 Q&T (AISI 4140 EQUIV)
3. WITH THERMISTOR: PTC 140°C × 3PCS
WIRED IN MAIN TERMINAL BOX



DWG.	C.COOK	02-01-18
------	--------	----------

TEC Westinghouse

DWG NO.
31057H258510

TECO Westinghouse

ISSUED 4/4/2019	PERFORMANCE DATA 3-PHASE INDUCTION MOTOR	ENCLOSURE TEFC
TYPE AEHHGD		CATALOG# CDP0756

NAMEPLATE INFORMATION

OUTPUT		POLE	FRAME SIZE	VOLTAGE	HZ	RATED AMBIENT	INS. CLASS	NEMA DESIGN	TIME RATING	SERVICE FACTOR
HP	KW									
75	56.0	6	405T	230/460	60	40°C	F	C	CONT.	1.15

VARIABLE FREQUENCY DRIVE SERVICE

VARIABLE TORQUE				OHMS/PHASE EQUIVALENT WYE CIRCUIT (AT RATED OPERATING TEMPERATURE 25°C)				
HZ	HP	RPM	TORQUE (lb-ft)	R1	R2	X1	X2	X _m
3~60	0.009~75	60~1200	0.788~333.7	0.0413	0.0839	0.2687	0.4559	11.509

CONSTANT TORQUE				CONSTANT HORSEPOWER			
HZ	HP	RPM	TORQUE (lb-ft)	HZ	HP	RPM	TORQUE (lb-ft)
6~60	7.5~75	120~1200	333.7	60~90	75	1200~1800	333.7~222.5

TYPICAL PERFORMANCE

FULL LOAD RPM	EFFICIENCY				POWER FACTOR			SOUND PRESSURE LEVEL @ 3 FT Db(A)
	FULL LOAD		3/4 LOAD %	1/2 LOAD %	FULL LOAD %	3/4 LOAD %	1/2 LOAD %	
	MIN.%	NOM.%						
1180	93.6	94.5	94.5	94.5	86.5	84.5	79	78

CURRENTS						NEMA KVA CODE LETTER	SAFE STALL TIME IN SECONDS	
NO LOAD		FULL LOAD		LOCKED ROTOR			COLD	HOT
AT 230 VOLT	AT 460 VOLT	AT 230 VOLT	AT 460 VOLT	AT 230 VOLT	AT 460 VOLT			
45.2	22.6	171.8	85.9	1086.0	543.0	G	26	18

TORQUE				INERTIA			ACCEL TIME (DOL)		ALLOWABLE STARTS PER HOUR	
FULL LOAD (lb-ft)	LOCKED ROTOR %FLT	PULL UP %FLT	BREAK DOWN %FLT	ROTOR WR ² (lb-ft ²)	NEMA LOAD WK ² (lb-ft ²)	MAX ALLOWABLE WK ² (lb-ft ²)	NEMA LOAD WK ² Sec	MAX ALLOWABLE WK ² Sec	COLD	HOT
333.70	200	175	225	37.862	904	2050	5.52	12.24	2	1

APPROVED:	K. Lo	DRAWING NO.	31057CDP0756	REVISION:	1
-----------	--------------	-------------	---------------------	-----------	----------

DATE:
December 28, 2010

CONNECTION DIAGRAM

CATALOG NO.:
CDP0756



SCHEMATIC - Δ / Y CONNECTION

ACROSS THE LINE CONNECTION



LINE
230 VOLT CONNECTION



LINE
460 VOLT CONNECTION

***CONTACT TWMC IF YOU HAVE ANY QUESTIONS
REGARDING THE MOTOR CONNECTION.**

PH: 1-800-873-8326