

POLE	HP	kW	Hz	VOLT	r/min(RPM)	INS	RATING	DIMENSION IN	APPROX WEIGHT	BEARINGS
6	200	149	60	460	1200	F	CONT.	INCH	2783 LBS.	DE: 6320 NDE: 6316

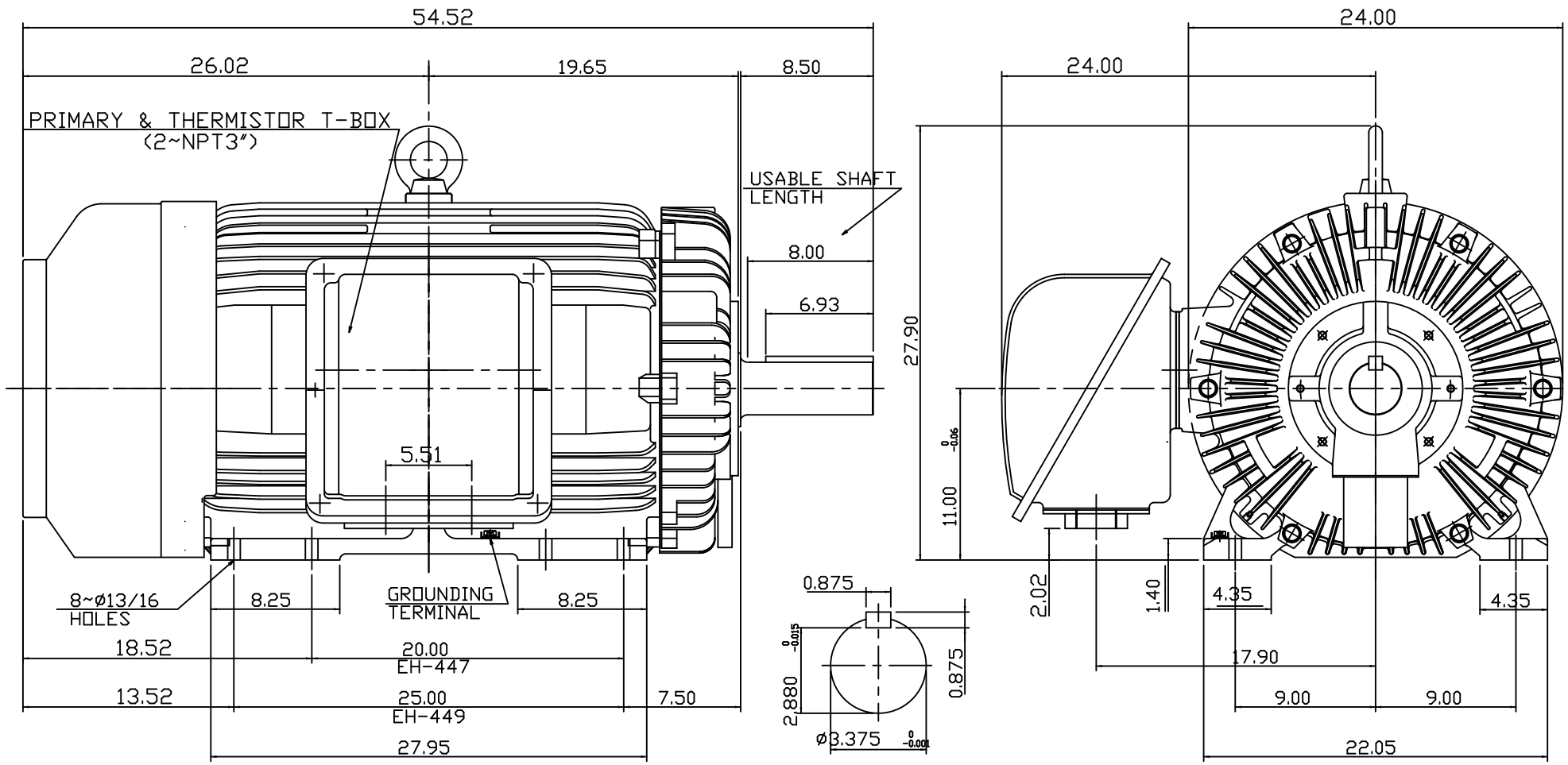

- NOTE:
1. DIMENSIONS IN INCHES
 2. FRAME NO. 449T
 3. F CLASS INSULATION, S.F.1.15
 4. FOR BELT SERVICE
 5. ENCLOSURE: IP55
 6. WITH THERMISTOR: PTC 140°C 3PCS
 7. SHAFT MATERIAL: SCM440 Q&T (AISI 4140 EQUIV)
 8. CORROSION PROOF

OUTLINE DIMENSIONS			
3-PHASE INDUCTION MOTOR			
MOTOR TYPE	AEHHGD	FRAME NO.	449T
CATALOG NO.	CDP2006T	DATE	02-01-2018

TEC Westinghouse			DWG NO.
			31057C562890
DWG.	C.COOK	02-01-18	

ISSUED 1-Apr-16	PERFORMANCE DATA 3-PHASE SQUIRREL CAGE HIGH EFFICIENCY INDUCTION MOTORS	MODEL AEHHGD
REVISED 13-Feb-17		



ee C C 0 0 2 A

TEFC, NEMA T-FRAME, DESIGN - C,
CLASS F, 40°C AMBIENT, CONTINUOUS DUTY,
S.F. 1.15 460V 60Hz

TYPICAL PERFORMANCE (460 V)

OUTPUT		POLE	FULL LOAD RPM	FRAME SIZE	EFFICIENCY(%)				POWER FACTOR(%)			CURRENT			TORQUE				ROTOR WK ² lb-ft ²	NEMA CODE LETTER
					FULL LOAD		3/4 LOAD	1/2 LOAD	FULL LOAD	3/4 LOAD	1/2 LOAD	FULL LOAD	208V USABLE	LOCKED ROTOR	FULL LOAD	LOCKED ROTOR	PULL UP	BREAK DOWN		
					NOM.	MIN.	NOM.	NOM.				(A)	ON-A	(A)	lb-ft	%FLT	%FLT	%FLT		
60	45	4	1775	364T	95.0	94.1	95.0	94.5	86.5	83.0	75.5	68	151	435	177.5	200	155	240	12.23	G
		6	1180	404T	94.5	93.6	94.5	94.1	87.0	86.5	80.5	68	151	435	267.0	220	185	250	33.54	G
		8	885	405T	93.0	91.7	93.6	93.6	81.0	78.0	68.0	75	165	435	356.0	200	180	230	32.55	G
75	55	4	1775	365T	95.4	94.5	95.4	95.0	86.5	83.5	75.5	85	188	543	221.9	200	165	250	14.67	G
		6	1180	405T	94.5	93.6	94.5	94.5	86.5	84.5	79.0	86	190	543	333.7	200	175	225	37.86	G
		8	890	444T	93.6	92.4	93.0	93.0	73.0	68.0	57.0	103	227	543	442.5	210	180	210	55.10	G
100	75	4	1775	405T	95.4	94.5	95.4	95.0	87.5	85.5	80.0	112	248	725	295.8	215	140	215	26.64	G
		6	1181	444T	95.0	94.1	94.5	93.6	82.5	80.0	73.0	119	264	725	444.6	200	150	240	56.00	G
		8	890	445T	93.6	92.4	93.0	93.0	78.0	74.0	65.0	128	284	725	589.9	230	180	250	72.80	G
125	90	4	1780	444T	95.4	94.5	95.0	94.1	85.0	83.0	77.0	144	319	908	368.7	200	140	220	44.30	G
		6	1182	445T	95.0	94.1	94.5	93.6	83.0	80.5	74.0	148	328	908	555.3	200	140	230	68.00	G
		8	890	447T	94.1	93.0	94.1	94.1	80.0	77.0	69.0	155	344	908	737.4	220	160	260	141.0	G
150	110	4	1783	445T	95.8	95.0	95.4	94.5	85.0	83.0	78.0	172	--	1085	441.7	210	160	270	52.00	G
		6	1185	447T	95.8	95.0	95.4	94.5	83.5	81.0	74.0	176	--	1085	664.6	200	160	220	103.0	G
		8	890	449T	94.1	93.0	94.1	94.1	80.0	77.0	69.0	187	--	1085	884.9	220	160	250	166.0	G
200	150	4	1785	447T	95.4	94.5	95.8	95.0	87.0	83.5	78.5	226	--	1450	588.3	200	140	210	73.50	G
		6	1186	449T	95.8	95.0	95.4	94.5	84.0	81.0	74.0	233	--	1450	885.4	200	140	210	125.0	G
		8	890	449T	94.5	93.6	94.1	94.1	82.5	77.0	69.0	240	--	1450	1180	200	160	230	221.0	G

- NOTE :
- The above are typical values based on test according to ANSI/IEEE standard 112 method B.
 - Breakdown & locked rotor torques are shown as average expected values.
 - Efficiency, power factor, speed and torque are the same for other voltages.
Current values vary inversely with voltage.
 - Tolerance according to NEMA MG1-12 & IEC 60034-1.
 - Data subject to change without notice.

APPD.	Liau-Shin Hung	21-Feb-17	TECO Electric & Machinery Co., Ltd.	DWG. NO.	31057D62114
CHKD.	Ho-Miuy Te	22-Feb-17		REV. 04	
DWN.	Davis Ting	13-Feb-17		2/6	

ITEM	A	K
01	M10	NPT2"
02	M16	NPT2"
03	M10	NPT2.5"
04	M16	NPT2.5"
05	M10	NPT3"
06	M16	NPT3"
07	M10	NPT3.5"
08	M16	NPT3.5"
09	M10	NPT4"
10	M16	NPT4"
11	M10	PF5"
12	M16	PF5"

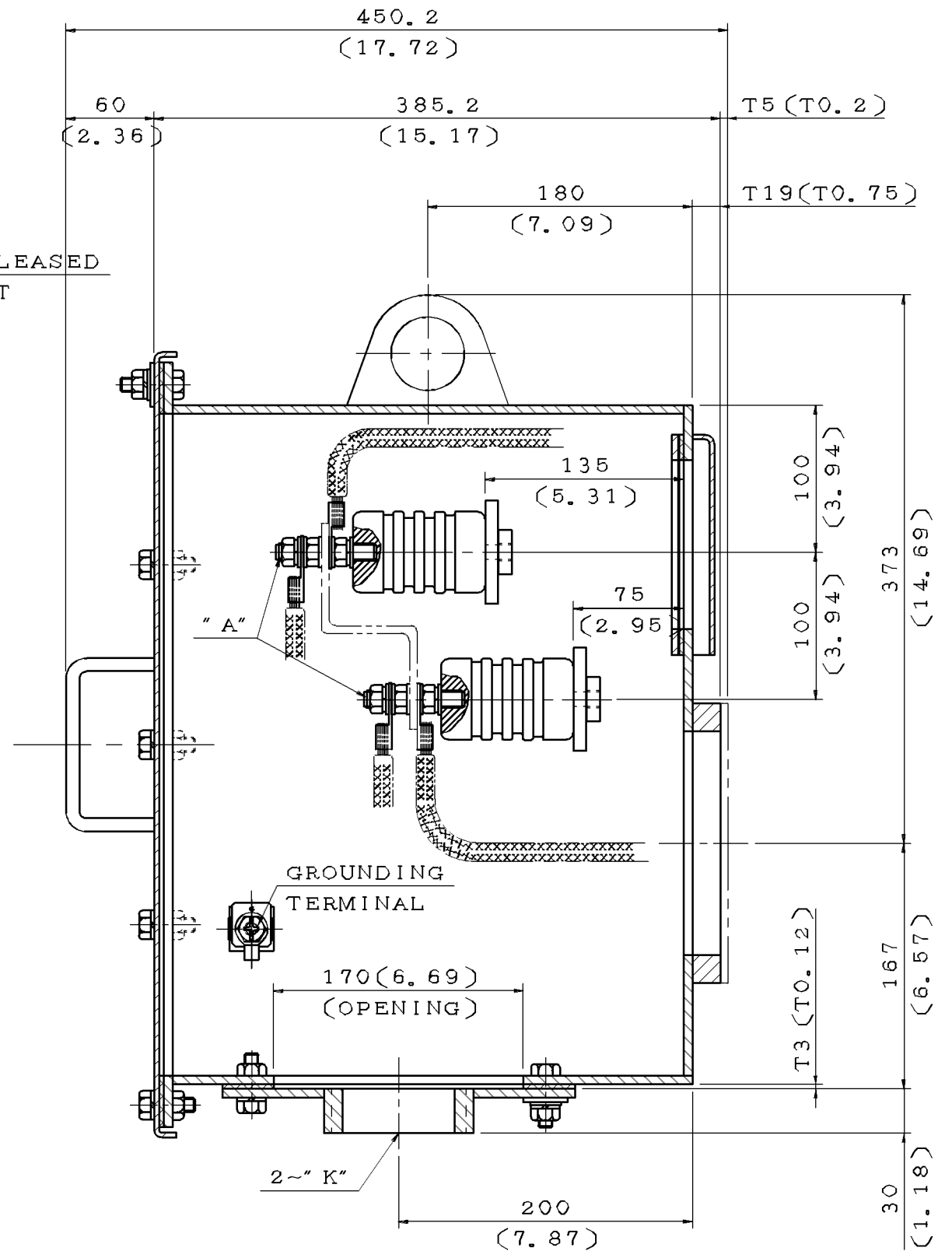
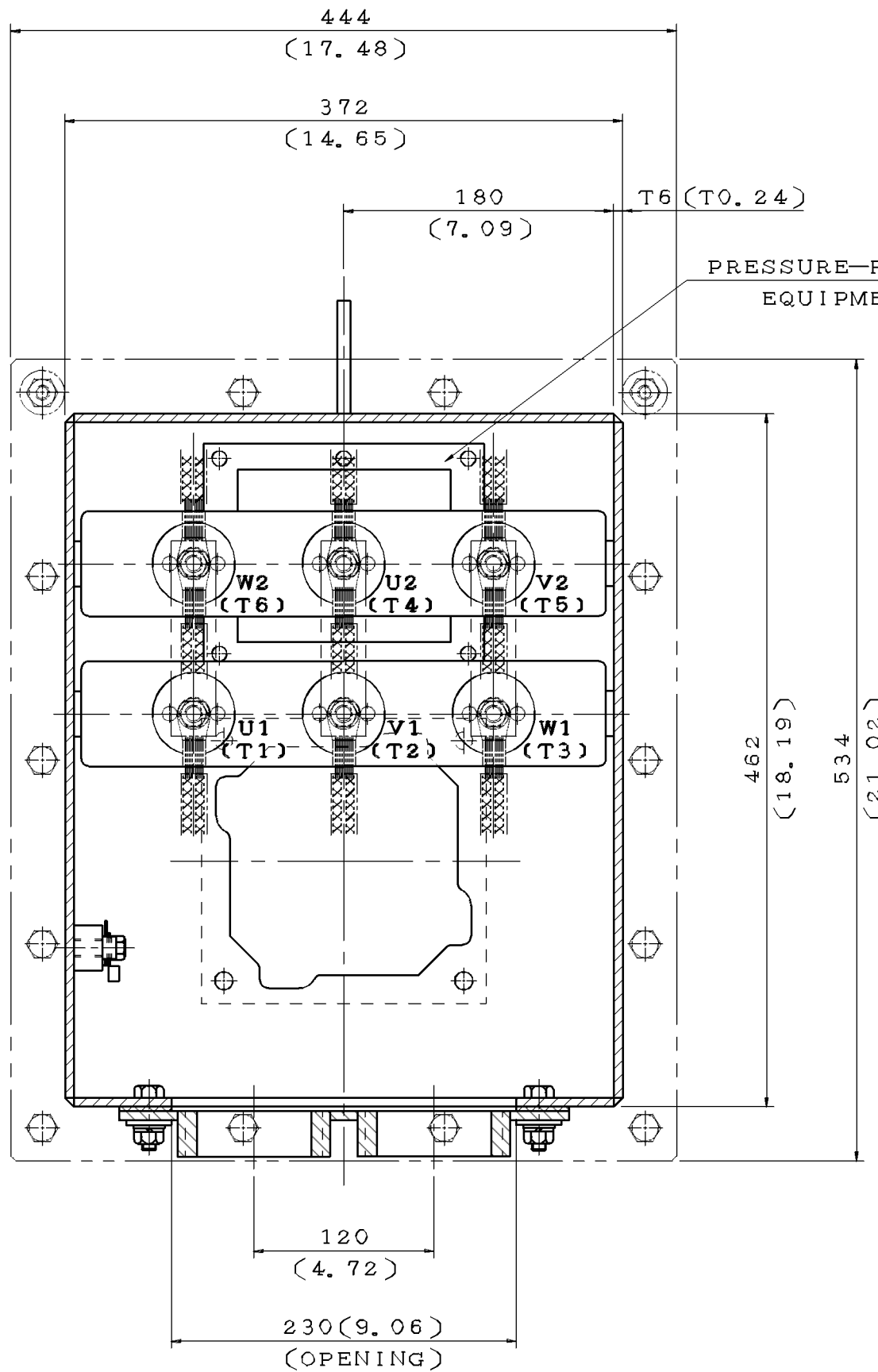

NOTE:
 1. DIMENSIONS IN mm(inch)
 2. PRIMARY T-BOX

DATE 08/25/2017

SCHEMATIC DRAWING

TERMINAL BOX

DWN.	J. WANG	JUL.28.2017
CHKD.	H. HUANG	JUL.28.2017
APPD.	C. LIU	JUL.28.2017

TECO® Westinghouse

DWG NO. REV:00

4B040W403

DATE	SCHEMATIC DRAWING TERMINAL BOX	MODEL
08/25/2017		CDP2006RZ

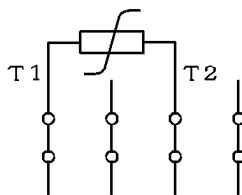
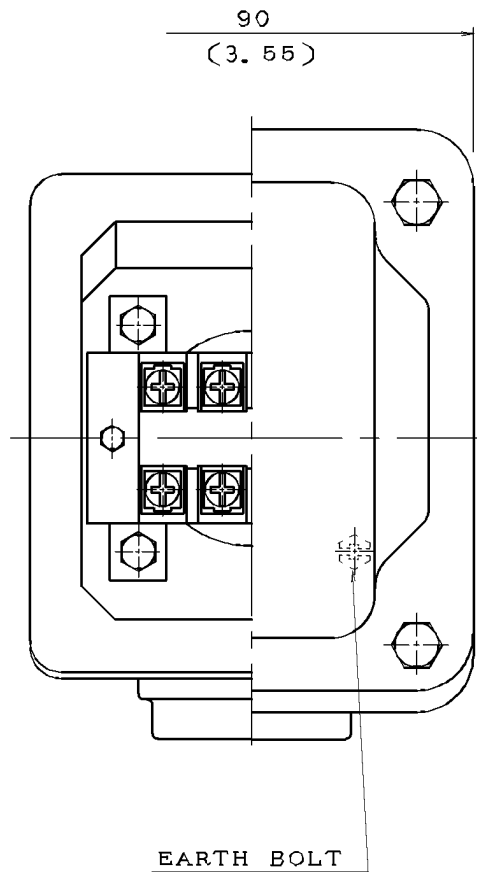
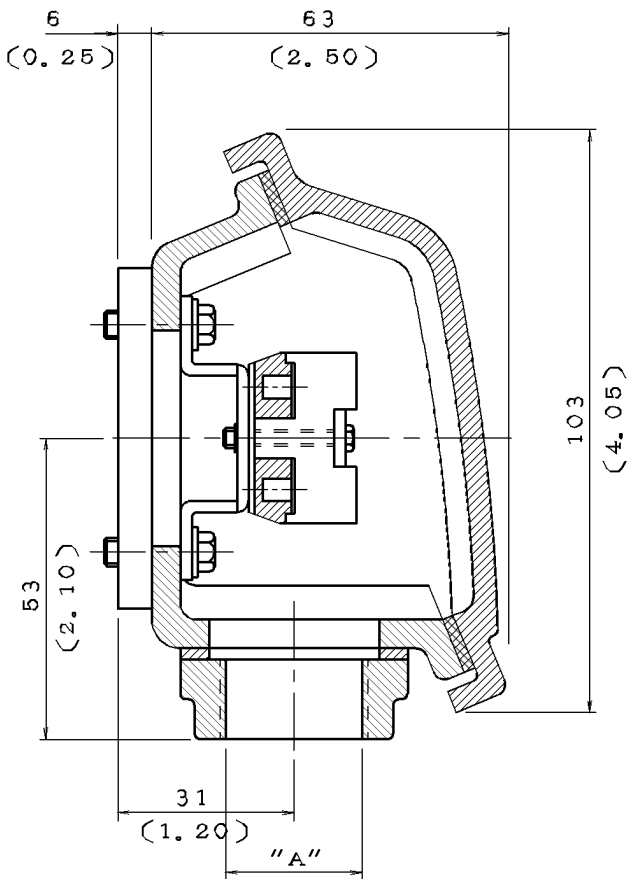

NOTE: 1. DIMENSIONS IN mm (inch)
 2. TW-06
 3. THERMISTOR T-BOX

ITEM	A
01	M20X1.5
02	M25X1.5
03	PF0.5"
04	PF0.75"
05	PF1"
06	PT0.5"
07	PT0.75"
08	NPT0.5"
09	NPT0.75"
10	NPT1"



DWN.	L. NIEH	MAY*21*2002
CHKD.	B. YANG	MAY*21*2002
APPD.	T. CHEN	MAY*21*2002

TECO Westinghouse

DWG NO. REV: 04

3A040M465

DATE	SCHEMATIC 6 LEADS	MODEL
08/25/2017		CDP2006RZ

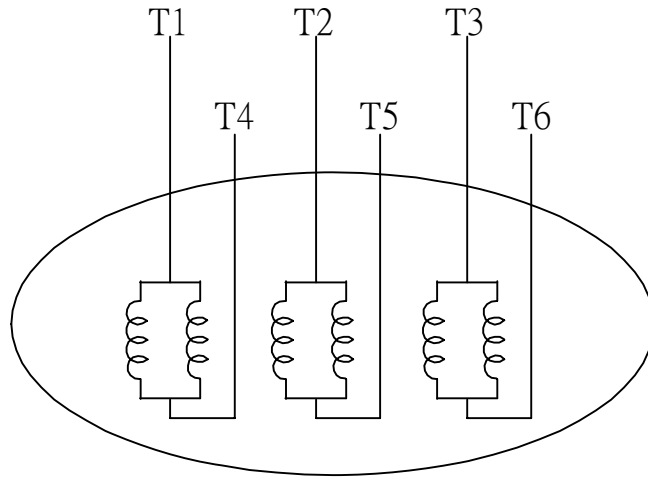

SCHEMATIC DIAGRAM - 6 LEADS

VOLTAGE	CONNECTION	ROTATION (VIEWED FROM NON-DRIVE END)
LOW (RUN. Δ)		
HIGH (START. Δ)		

DWN.	S.HUANG	MAR • 03 • 2003
CHKD.	T.HSIAO	MAR • 03 • 2003
APPD.	T.HSIAO	MAR • 03 • 2003



DWG NO.	REV: 00
3A061H634W	