

ISSUED
2-Dec-16

REVISED
20-Feb-17

OUTLINE DIMENSION SHEET

3-PHASE INDUCTION MOTOR
FRAME SIZE 449T

MODEL
AEHHGD

PAGE

Totally Enclosed Fan - Cooled Type, Squirrel - Cage Rotor

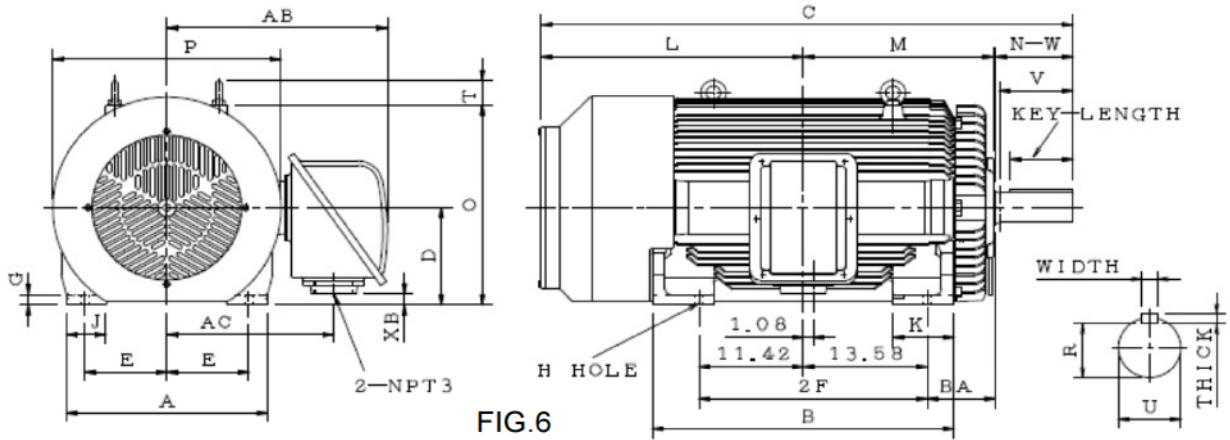

FIG.6

Dimension in inches

Output (HP)			FRAME SIZE	FIG. NO.	Mounting				A	B	C	D	G	J	K	L	M
4P	6P	8P			E	2F	H	BA									
350	300	—	449T	6	9.00	25.00	0.81	7.50	22.05	33.05	58.63	11.00	1.20	4.35	6.70	29.05	20.67
350	300	—	449TZ		9.00	25.00	0.81	7.50	22.05	33.05	58.63	11.00	1.20	4.35	6.70	29.05	20.67

FRAME SIZE	O	P	T	Key			Keyseat	Shaft Extension			Terminal Housing			Bearings	
				WIDTH	THICK	LENGTH	R	N-W	U	V	AB	AC	XB	DRIVE END	OPPOSITE DRIVE END
449T	22.6	25.45	4.3	0.875	0.875	6.91	2.880	8.500	3.375	8.00	25.15	19.05	1.25	6320	6316
449TZ	22.6	25.45	4.3	0.875	0.875	8.50	2.880	10.12	3.375	9.67	25.15	19.05	1.25	NU320	6316

- Note :**
1. Dimension D tolerance : +0.00 inches, -0.06 inch.
 2. Dimension U tolerance : +0.000 incjes, -0.001 inches.
 3. Dimension R tolerance : +0.000 inches, -0.015 inches.
 4. Dimension V is the length of straight part of shaft.

APPD.	Liau-Shin Hung	21-Feb-17
CHKD.	Hspeter	21-Feb-17
DWN.	Lynn Tsai	20-Feb-17

TECO Electric & Machinery Co., Ltd.

DWG NO.
31049J87104
REV. 01

ISSUED 1-Apr-16	PERFORMANCE DATA 3-PHASE SQUIRREL CAGE HIGH EFFICIENCY INDUCTION MOTORS	MODEL AEHHGD
REVISED 13-Feb-17		



ee C C 0 0 2 A

TEFC, NEMA T-FRAME, DESIGN - A,
CLASS F, 40°C AMBIENT, CONTINUOUS DUTY,
S.F. 1.15 460V 60Hz

TYPICAL PERFORMANCE

(460 V)

OUTPUT		POLE	FULL LOAD RPM	FRAME SIZE	EFFICIENCY(%)			POWER FACTOR(%)			CURRENT			TORQUE				ROTOR WK ² lb-ft ²	NEMA CODE LETTER	
					FULL LOAD		3/4 LOAD	1/2 LOAD	FULL LOAD	3/4 LOAD	1/2 LOAD	FULL LOAD	208V USABLE	LOCKED ROTOR	FULL LOAD	LOCKED ROTOR	PULL UP			BREAK DOWN
					NOM.	MIN.	NOM.	NOM.	(A)	ON-A	(A)	lb-ft	%FLT	%FLT	%FLT					
250	185	4	1787	449T	96.2	95.4	96	95.5	85.0	81.0	71.5	286	--	2050	734.5	200	160	275	70.8	J
		6	1189	449T	95.8	95	95.5	95	78.5	72.5	60.0	311	--	2350	1104	220	180	275	131.54	J
300	225	4	1788	449T	96.2	95.4	96	95.5	84.0	80.5	70.5	348	--	2750	881.0	240	200	275	88.95	J
		6	1188	Hybrid 449T	95.8	95	95.5	95	82.5	78.5	70.0	355	--	2850	1326	200	160	250	152.59	J
350	260	4	1786	Hybrid 449T	96.2	95.4	95.8	95.5	88.5	87.0	82.0	385	--	3100	1029	230	190	250	105.29	H

- NOTE :
- The above are typical values based on test according to ANSI/IEEE standard 112 method B.
 - Breakdown & locked rotor torques are shown as average expected values.
 - Efficiency, power factor, speed and torque are the same for other voltages.
Current values vary inversely with voltage.
 - Tolerance according to NEMA MG1-12 & IEC 60034-1.
 - Data subject to change without notice.

APPD.	Liau-Shin Hung	21-Feb-17	TECO Electric & Machinery Co., Ltd.	DWG. NO.	31057D62114
CHKD.	Ho-Miuy Te	22-Feb-17		REV. 04	
DWN.	Robo.Huang	13-Feb-17		3/6	

ITEM	A	K
01	M10	NPT2"
02	M16	NPT2"
03	M10	NPT2.5"
04	M16	NPT2.5"
05	M10	NPT3"
06	M16	NPT3"
07	M10	NPT3.5"
08	M16	NPT3.5"
09	M10	NPT4"
10	M16	NPT4"
11	M10	PF5"
12	M16	PF5"

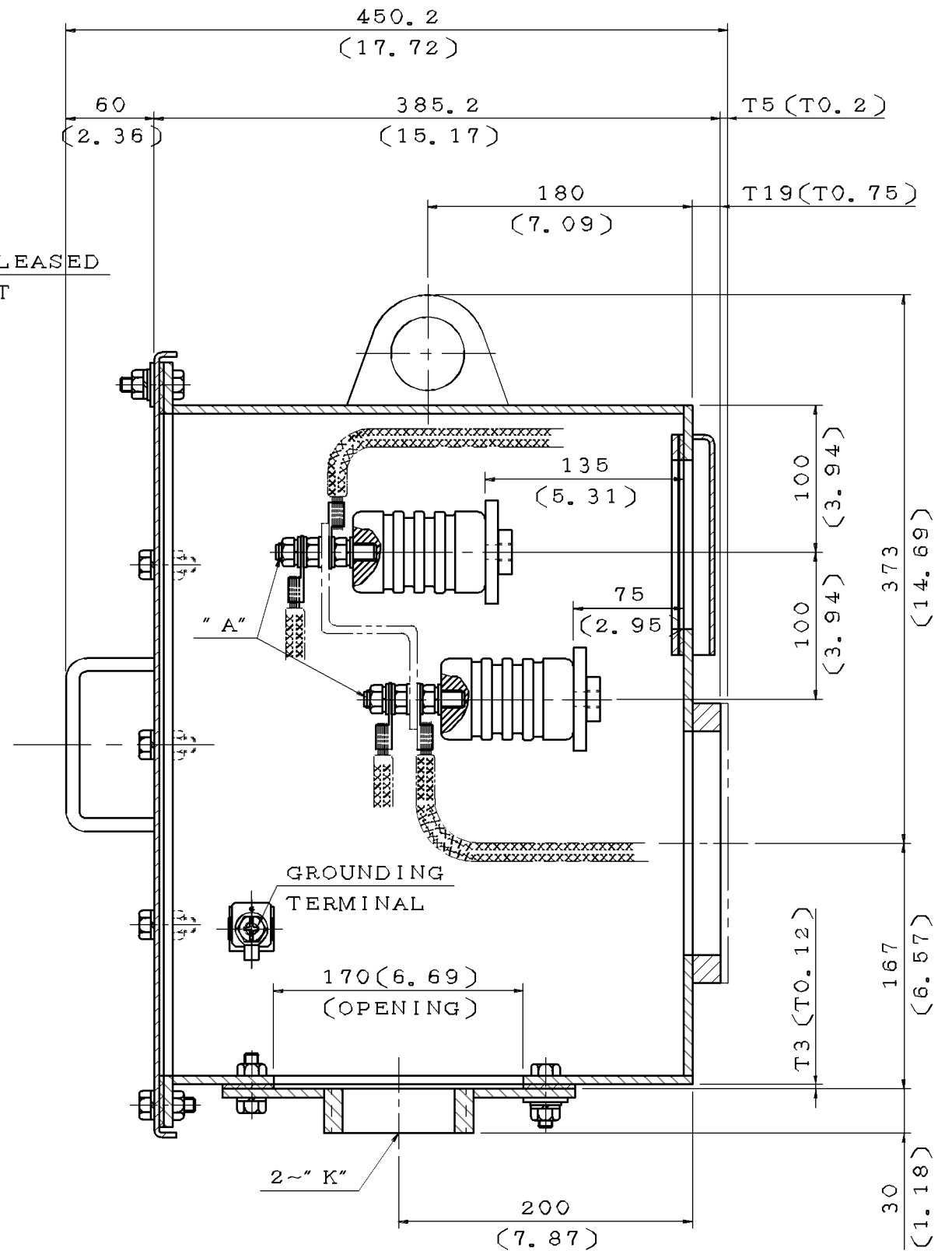
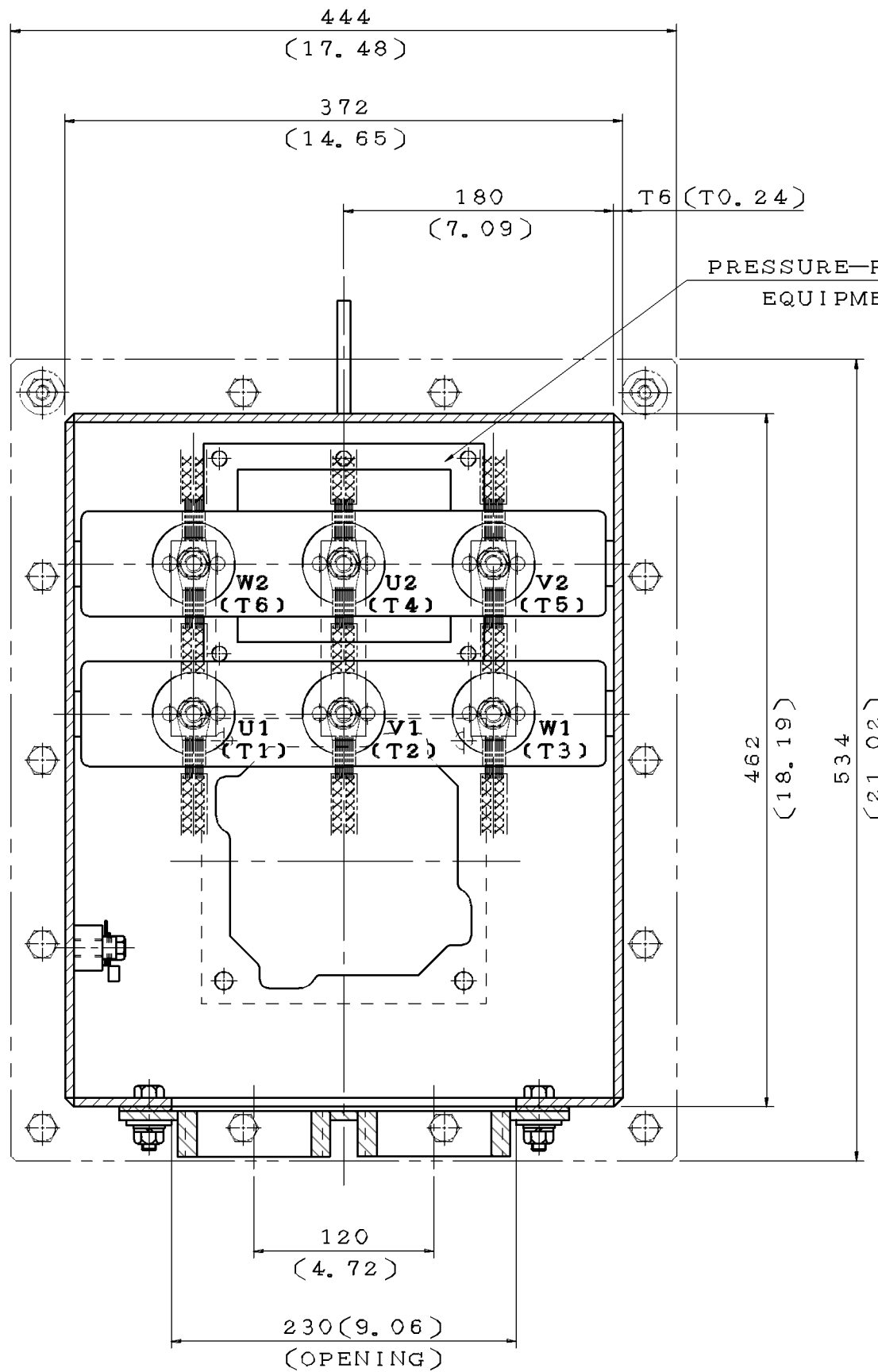

NOTE:
 1. DIMENSIONS IN mm(inch)
 2. PRIMARY T-BOX

DATE 08/25/2017

SCHEMATIC DRAWING

TERMINAL BOX

DWN.	J. WANG	JUL.28.2017
CHKD.	H. HUANG	JUL.28.2017
APPD.	C. LIU	JUL.28.2017

TECO Westinghouse

DWG NO. REV:00

4B040W403

DATE	SCHEMATIC DRAWING TERMINAL BOX	MODEL
08/25/2017		CDP2006RZ

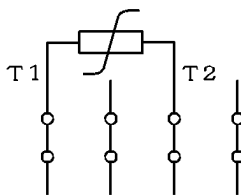
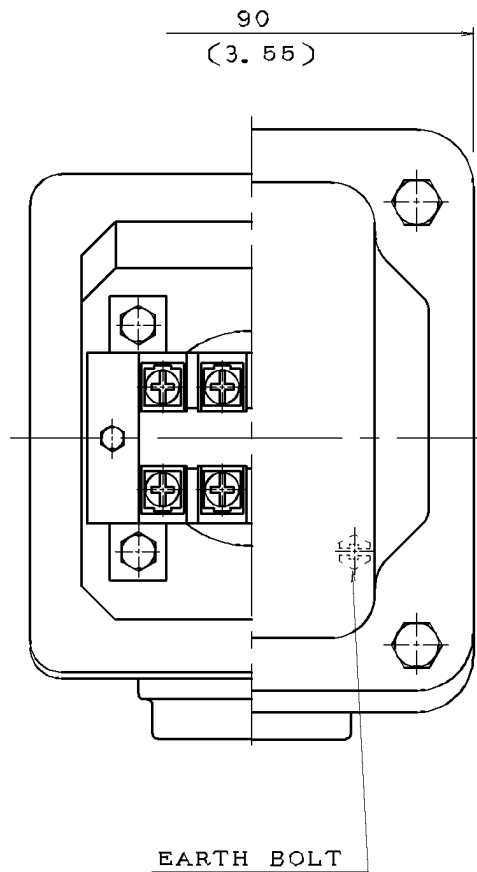
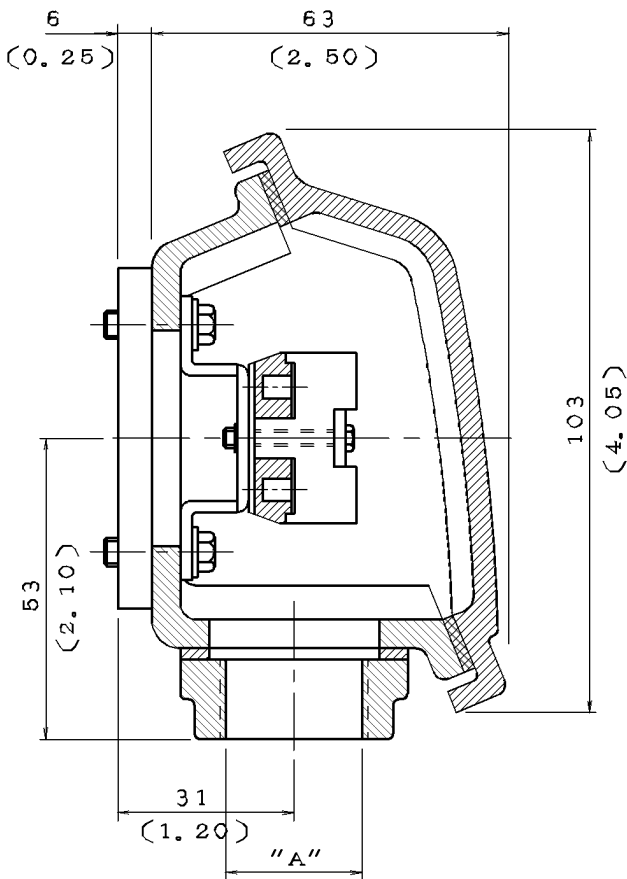

NOTE: 1. DIMENSIONS IN mm (inch)
 2. TW-06
 3. THERMISTOR T-BOX

ITEM	A
01	M20X1.5
02	M25X1.5
03	PF0.5"
04	PF0.75"
05	PF1"
06	PT0.5"
07	PT0.75"
08	NPT0.5"
09	NPT0.75"
10	NPT1"



DWN.	L. NIEH	MAY*21*2002
CHKD.	B. YANG	MAY*21*2002
APPD.	T. CHEN	MAY*21*2002

TECO **Westinghouse**

DWG NO. REV: 04

3A040M465

DATE	SCHEMATIC 6 LEADS	MODEL
08/25/2017		CDP2006RZ

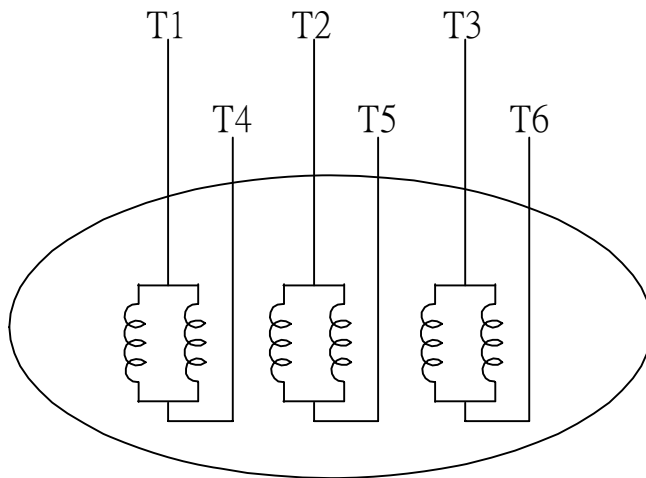

SCHEMATIC DIAGRAM - 6 LEADS

VOLTAGE	CONNECTION	ROTATION (VIEWED FROM NON-DRIVE END)
LOW (RUN. Δ)	<p>Diagram showing a delta connection for low voltage. Three horizontal lines represent supply lines L1, L2, and L3. The motor windings are connected in a triangle. Lead T1 is connected to L1, T2 to L2, and T3 to L3. Leads T4, T5, and T6 are also shown connected to the vertices of the triangle.</p>	<p>A curved arrow indicating clockwise rotation when viewed from the non-drive end.</p>
HIGH (START. Δ)	<p>Diagram showing a star connection for high voltage. Three horizontal lines represent supply lines L1, L2, and L3. The motor windings are connected in a star configuration. Lead T1 is connected to L1, T2 to L2, and T3 to L3. Leads T4, T5, and T6 are also shown connected to the star point.</p>	<p>A curved arrow indicating clockwise rotation when viewed from the non-drive end.</p>

DWN.	S.HUANG	MAR • 03 • 2003
CHKD.	T.HSIAO	MAR • 03 • 2003
APPD.	T.HSIAO	MAR • 03 • 2003



DWG NO.	REV: 00
3A061H634W	