

BALDOR® • RELIANCE 

Product Information Packet

CECP84107T-4

25HP,3520RPM,3PH,60HZ,284TSC,TEFC,F1

Part Detail							
Revision:	D	Status:	PRD/A	Change #:		Proprietary:	No
Type:	AC	Elec. Spec:	10WGZ242	CD Diagram:	CD0006	Mfg Plant:	
Mech. Spec:		Layout:	10LY-000-161	Poles:	02	Created Date:	01-15-2019
Base:		Eff. Date:	03-07-2022	Leads:	3#10		

Specs			
Catalog Number:	CECP84107T-4	Inverter Code:	Inverter Duty
Enclosure:	TEFC	IP Rating:	IP56
Frame:	284TSC	KVA Code:	F
Frame Material:	Iron	Lifting Lugs:	Standard Lifting Lugs
Output @ Frequency:	25.000 HP @ 60 HZ	Locked Bearing Indicator:	Locked Bearing
Synchronous Speed @ Frequency:	3600 RPM @ 60 HZ	Motor Lead Quantity/Wire Size:	3 @ 10 AWG
Voltage @ Frequency:	460.0 V @ 60 HZ	Motor Lead Exit:	Ko Box
XP Class and Group:	CLI GP A,B,C,D	Motor Lead Termination:	Ring Terminals
XP Division:	Division II	Motor Type:	1048M
Agency Approvals:	CCSA US	Mounting Arrangement:	F1
	CSA EEV	Power Factor:	90
	UR	Product Family:	Chem Process S/P 32-8 IEEE 841
Auxillary Box:	No Auxillary Box	Pulley End Bearing Type:	Ball
Auxillary Box Lead Termination:	None	Pulley Face Code:	C-Face
Base Indicator:	Rigid	Pulley Shaft Indicator:	Standard
Bearing Grease Type:	Polyrex EM (-20F +300F)	Rodent Screen:	None
Blower:	None	Shaft Extension Location:	Pulley End
Constant Torque Speed Range:	6	Shaft Ground Indicator:	No Shaft Grounding

Current @ Voltage:	28.000 A @ 460.0 V	Shaft Rotation:	Reversible
Design Code:	B	Shaft Slinger Indicator:	No Slinger
Drip Cover:	No Drip Cover	Speed Code:	Single Speed
Duty Rating:	CONT	Motor Standards:	NEMA
Electrically Isolated Bearing:	Not Electrically Isolated	Starting Method:	Direct on line
Enclosure Modification:	841	Thermal Device - Bearing:	None
Feedback Device:	NO FEEDBACK	Thermal Device - Winding:	None
Front Face Code:	Standard	Vibration Sensor Indicator:	No Vibration Sensor
Front Shaft Indicator:	None	Winding Thermal 1:	None
Heater Indicator:	No Heater	Winding Thermal 2:	None
Insulation Class:	F	XP Temp Code:	T3

Nameplate NP3190												
STK.NO.	CECP84107T-4		P/N			ENCLOSURE	TEFC					
SPEC.	10-0000-0476		CC	010A	FRAME	284TSC		S/N				
HP	25		CLASS	F	HZ	60		ODE BRG	6311	DE BRG	6311	
RPM	3520	RPM MAX	5400		PH	3	DES	B		D.E. BRG.	55BC03X30X	
VOLT	460		KVA-CODE	F		O.D.E. BRG.	55BC03X30X					
AMP	28		MOTOR WEIGHT	440		GREASE	POLYREX EM					
RATING	40C AMB-CONT		MAX. KVAR	3.1		BLANK						
NEMA-NOM-EFF	91.7	# OF ROTOR BARS	28		SER.F.	1.15		IP	56			
G.MIN.EFF	90.2	# OF STATOR SLOTS	36		PF	90		INV.TYPE	PWM			
TEMP CODE	T3		INVERTER-TEMP-CODE	200								
TEMP =	200		C HP FR	60		C HP TO	90					
CT HZ FROM	1.3		CT HZ TO	60								
HTR-VOLTS			HTR-AMPS			HTR-WATTS			MAX. SPACE HEATER TEMP.			
									VT HZ FROM	0-	VT HZ TO	60

Parts List		
Part Number	Description	Quantity
SA365113	SA 10-0000-0476	1.000 EA
RA354486	RA 10-0000-0476	1.000 EA
LB1115N	LABEL,LIFTING DEVICE (ON ROLLS)	1.000 EA
LB1119N	WARNING LABEL	1.000 EA
LC0006	CONNECTION LABEL	1.000 EA
LB1449	DIV-2/NEC WARNING LABEL	1.000 EA
NP3190	SS IEEE841 INV DIV-2 UL CSA-C US EEV	1.000 EA
85XU0407S04	4X1/4 U DRIVE PIN STAINLESS	4.000 EA
MN416A01	TAG-INSTAL-MAINT no wire (2100/bx) 4/22	1.000 EA
WD1000B49	T&B C73,RING TERMINAL 10-12 AWG 3/8 STUD	3.000 EA
WD1000B16	T&B CX70TN OR L70P TERMINAL LUG	1.000 EA
80XN3816A12	SET SCREW,HEX SOCKET CUP POINT,3/8-16 X	4.000 EA
10FH1007A24LP5	FAN COVER W/1.00 SLOT @ 6:00	1.000 EA
HW1001A31	LOCKWASHER 5/16, ZINC PLT.591 OD, .319 I	3.000 EA
10XN3118K20	5/16-18 X 1 1/4 GRADE 5 STEEL ZC PLATED	3.000 EA
09FN3001C02	EXTERNAL FAN, PLASTIC (COMES W/SCREW FRO	1.000 EA
HW2500A25	WOODRUFF KEY USA #1008 #BLOW CARBON STEE	1.000 EA
MJ1000A02	GREASE, MOBIL POLYREX EM - 124047	0.130 LB
10XN2520K06	1/4-20 X 3/8" HX HD SCREWGRADE 5, ZINC P	1.000 EA
10EP1110A02LP5	FR ENDPLATE, MACH W/PRIMER & PAINT	1.000 EA
10XN3816K28	3/8-16 X 1.75 HEX HD CAP SCREW, GRADE 5	4.000 EA
HW1001A38	LOCKWASHER 3/8, ZINC PLT .688 OD, .382 I	4.000 EA
HW4601A53	INPRO/SEAL VBXX FOR 311 BEARING/310 FRAM	1.000 EA
HW5100A13	W4627-047 WVY WSHER	1.000 EA

Parts List (continued)		
Part Number	Description	Quantity
HA4017A02	.125X2.50 GREASER EXTENS.F/S	1.000 EA
HA4017A02	.125X2.50 GREASER EXTENS.F/S	1.000 EA
HW4019A01	PIPE COUPLING 1/8 NPT,STEEL,ZINC COATING	1.000 EA
10XN3118K40	5/16-18 X 2.50" HEX HD, GRADE 5	4.000 EA
HA4051A00	PLASTIC CAP FOR GREASE FITTING	1.000 EA
HW4500A21	1618BALEMITE FITTING 825 UNIVERSAL	1.000 EA
HW4500A17	317400 ALEMITE GREASE RELIEF	1.000 EA
HW4500A20	1/8NPT SL PIPE PLUG	1.000 EA
HA4002A03	#304 S.S. DRAIN FITTING, .125 NPT (.44 H	1.000 EA
10EP1305A116P	PU ENDPLATE, MACH W/INPRO SEAL & EPOXY P	1.000 EA
HW1001A38	LOCKWASHER 3/8, ZINC PLT .688 OD, .382 I	4.000 EA
10XN3816K28	3/8-16 X 1.75 HEX HD CAP SCREW, GRADE 5	4.000 EA
HW4601A53	INPRO/SEAL VBXX FOR 311 BEARING/310 FRAM	1.000 EA
10XN3118K40	5/16-18 X 2.50" HEX HD, GRADE 5	4.000 EA
HA4051A00	PLASTIC CAP FOR GREASE FITTING	1.000 EA
HW4500A03	GREASE FITTING, .125 NPT 1610(ALEMITE) 8	1.000 EA
HW4500A17	317400 ALEMITE GREASE RELIEF	1.000 EA
HW4500A20	1/8NPT SL PIPE PLUG	1.000 EA
HA4002A03	#304 S.S. DRAIN FITTING, .125 NPT (.44 H	1.000 EA
10CB1000A09P	KOBX, MACH W/1.50 NPT & PRIMER	1.000 EA
09GS1010	GASKET, DWG, LEADWIRE SEPERATOR	1.000 EA
10XN3118K16	5/16-18 X 1' GRADE #5, STL, ZINC PLATE	4.000 EA
HW1001A31	LOCKWASHER 5/16, ZINC PLT.591 OD, .319 I	4.000 EA
WD1000B16	T&B CX70TN OR L70P TERMINAL LUG	1.000 EA

Product Information Packet: CECP84107T-4 - 25HP,3520RPM,3PH,60HZ,284TSC,TEFC,F1

59XW2520G07	.25-20X.44,HEX SER WSHR,TAPTITE 2,GREEN	1.000 EA
10CB1503A01P	CONDUIT BOX LIPPED LID, MACH W/EPXY PRMR	1.000 EA
14GS1003	GASKET CONDUIT BOX LID, NEOP	1.000 EA
10XN2520K16	1/4-20 X 1" HX HD SCRW GRADE 5, ZINC P	4.000 EA
HW1001A25	LOCKWASHER 1/4, ZINC PLT .493 OD, .255 I	4.000 EA
MG1025N19	WILKOFASST, 778.50, RELIANCE BLUE-GREEN	0.125 GA
MJ5001A27	32220KN GRAY SEALER *MIN BUY 4 QTS=1GAL	0.031 QT
MJ5001A14	DYNAPRO SEALANT, CP MTR VC#2508050 (603	0.033 EA
MJ5002A01	SILICON RUBBER SEALANT, 732CL 10.3 OZ TU	0.025 EA
10PA1000	PACKAGING GROUP COMBINED PRINT PK1023A06	1.000 EA
HW2501G17	KEY, 3/8 SQ X 1.875	1.000 EA
MJ5004A59	ADHESIVE LOCTITE #401 SURFACE INSENSITIV	0.010 EA

AC Induction Motor Performance Data

Record # 47223

Typical performance - not guaranteed values

Winding: 10WGZ242-R004		Type: 1048M	Enclosure: TEFC
Nameplate Data		460 V, 60 Hz: Single Voltage Motor	
Rated Output (HP)	25	Full Load Torque	37.3 LB-FT
Volts	460	Start Configuration	direct on line
Full Load Amps	28	Breakdown Torque	103 LB-FT
R.P.M.	3520	Pull-up Torque	42.1 LB-FT
Hz	60 Phase	Locked-rotor Torque	54 LB-FT
NEMA Design Code	B KVA Code	Starting Current	171 A
Service Factor (S.F.)	1.15	No-load Current	6.99 A
NEMA Nom. Eff.	91.7 Power Factor	Line-line Res. @ 25°C	0.29072 Ω
Rating - Duty	40C AMB-CONT	Temp. Rise @ Rated Load	57°C
S.F. Amps		Temp. Rise @ S.F. Load	70°C
		Locked-rotor Power Factor	23.3

Load Characteristics 460 V, 60 Hz, 25 HP

% of Rated Load	25	50	75	100	125	150	S.F.
Power Factor	69	83	89	90	90	90	90
Efficiency	87.8	91.6	92.2	91.8	90.9	89.7	91.3
Speed	3580.1	3563.2	3542.7	3521.3	3497	3469.9	3507
Line amperes	10.1	15.4	21.7	28.3	35.7	43.5	32.7

Performance Graph at 460V, 60Hz, 25.0HP Typical performance - Not guaranteed values

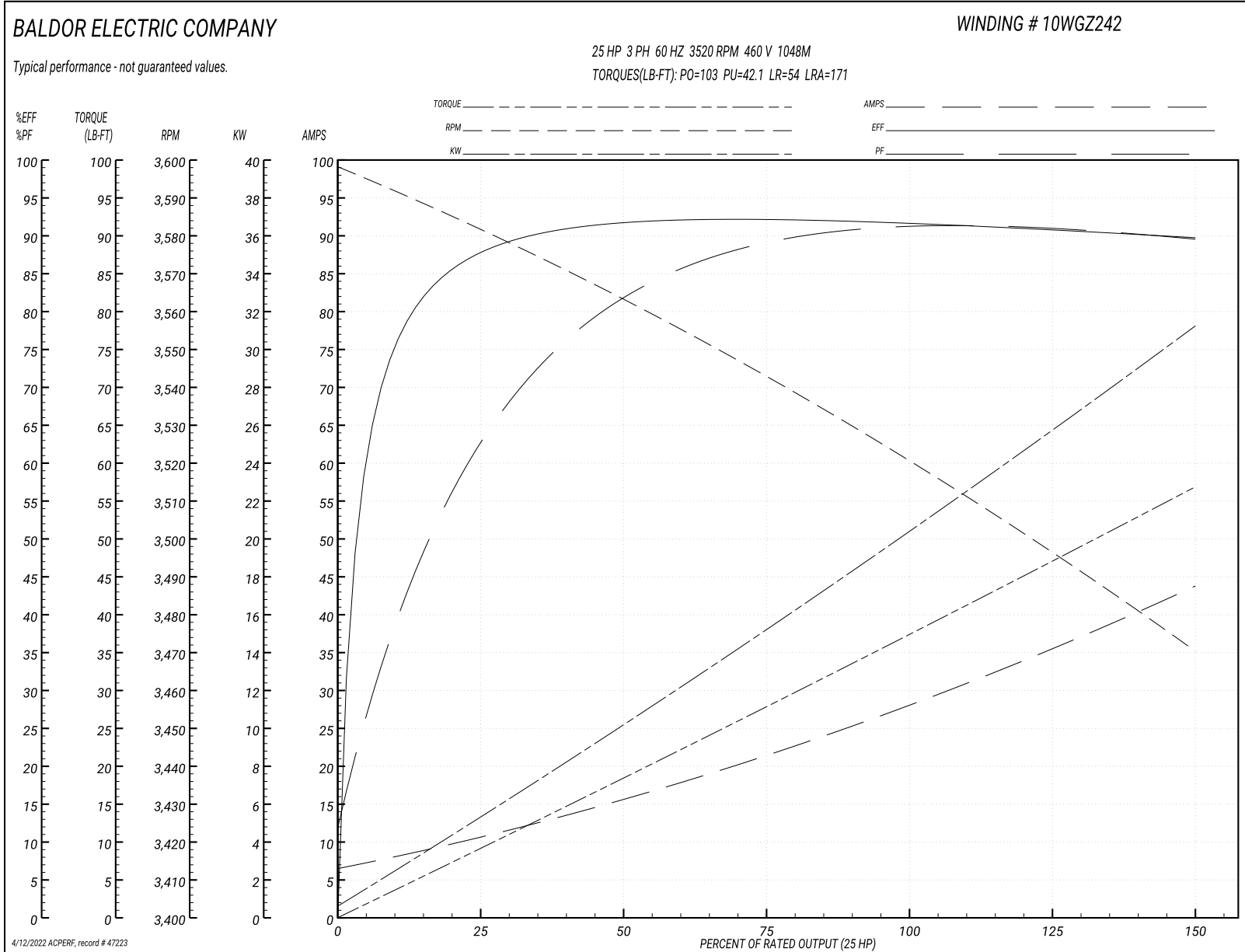

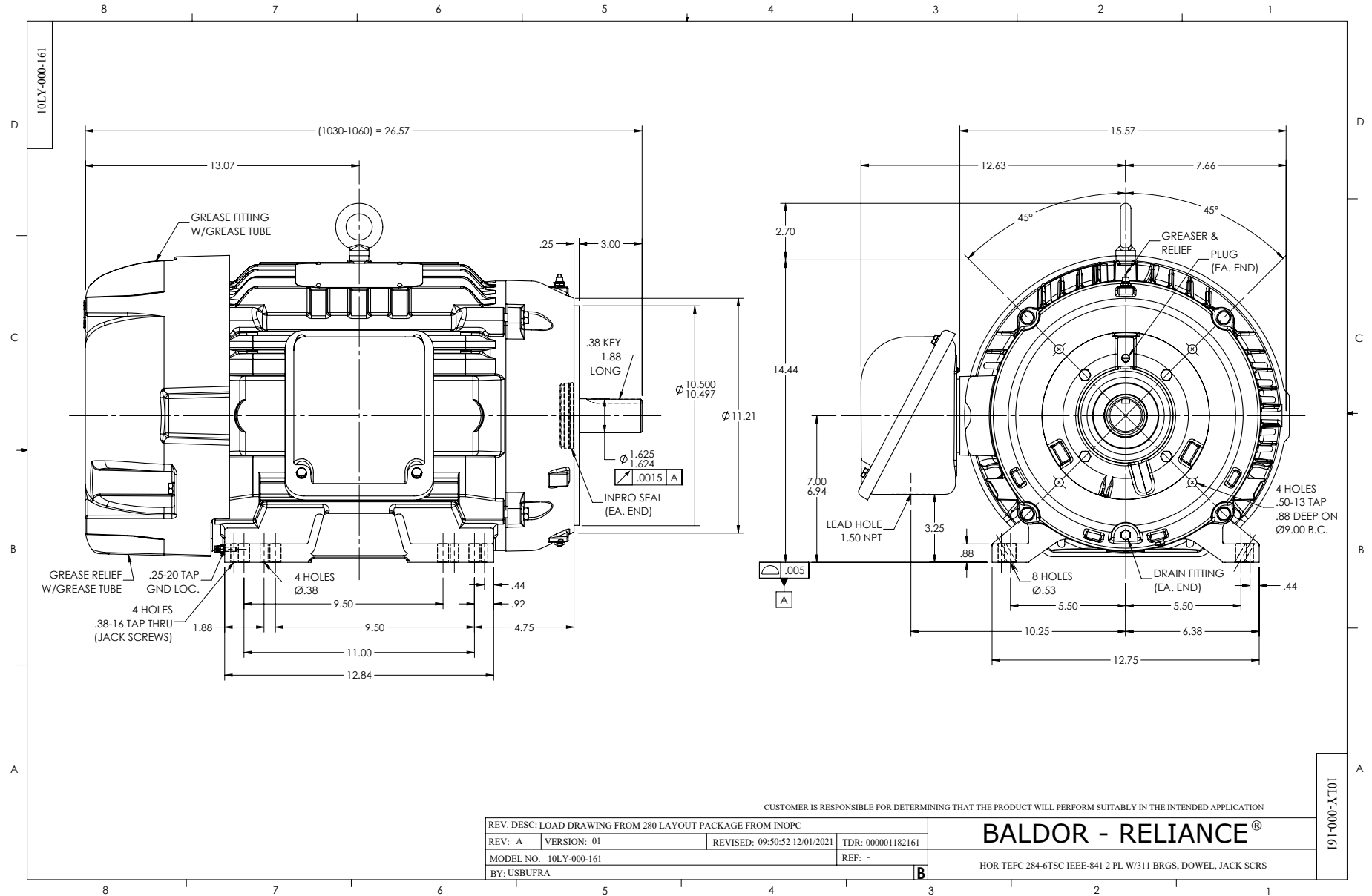

CD0006

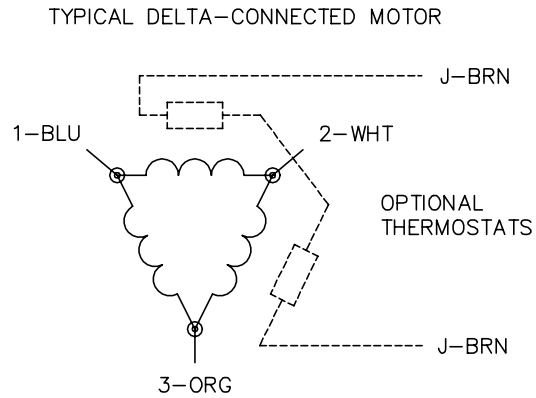
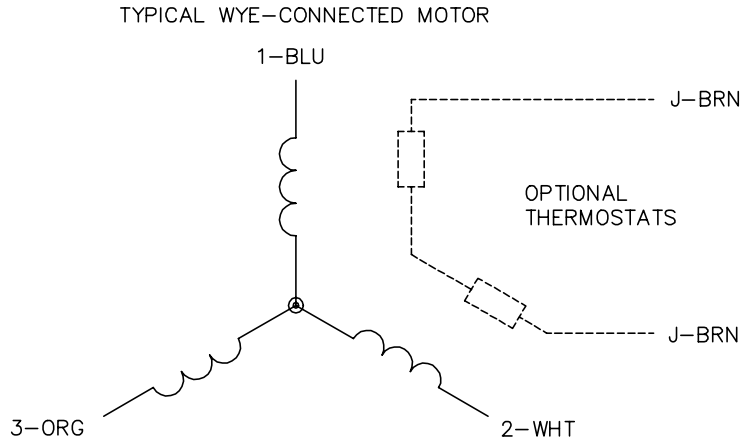

NOTES:

1. THREE LEAD MOTOR MAY BE EITHER WYE CONNECTED OR DELTA CONNECTED.
2. INTERCHANGE ANY TWO LINE LEADS TO REVERSE ROTATION.
3. OPTIONAL THERMOSTATS ARE PROVIDED WHEN SPECIFIED.
4. ACTUAL NUMBER OF INTERNAL PARALLEL CIRCUITS MAY VARY.
5. LEAD COLORS ARE OPTIONAL. LEADS MUST BE NUMBERED AS SHOWN.

CD0006

REV. DESC: ADD CLASS CONN00000007		
REV. LTR: E	VERSION: 01	TDR: 000001099922
FILE: \AAA\00005\141	REVISED: 10:24:49 02/19/2019	BY: ENBRIRO
MTL: -		

BALDOR - RELIANCE®

3PH, SV, 3 LEADS, WYE OR DELTA CONNECTED

SH 1 of 1

Marketing maintained PDF of MN416:

<http://www.baldor.com/support/Literature/Load.ashx/MN416?ManNumber=MN416>