

BALDOR® • RELIANCE 

Product Information Packet

CECP84111T-4

25HP, 1180RPM, 3PH, 60HZ, 324TC, TEFC, F1

Part Detail							
Revision:	B	Status:	PRD/A	Change #:		Proprietary:	No
Type:	AC	Elec. Spec:	12WGY445	CD Diagram:	CD0006	Mfg Plant:	
Mech. Spec:		Layout:	12LY-000-140	Poles:	06	Created Date:	01-15-2019
Base:		Eff. Date:	08-31-2020	Leads:	3#8		

Specs			
Catalog Number:	CECP84111T-4	Inverter Code:	Inverter Duty
Enclosure:	TEFC	IP Rating:	IP56
Frame:	324TC	KVA Code:	G
Frame Material:	Iron	Lifting Lugs:	Standard Lifting Lugs
Output @ Frequency:	25.000 HP @ 60 HZ	Locked Bearing Indicator:	Locked Bearing
Synchronous Speed @ Frequency:	1200 RPM @ 60 HZ	Motor Lead Quantity/Wire Size:	3 @ 8 AWG
Voltage @ Frequency:	460.0 V @ 60 HZ	Motor Lead Exit:	Ko Box
XP Class and Group:	CLI GP A,B,C,D	Motor Lead Termination:	Ring Terminals
XP Division:	Division II	Motor Type:	1264M
Agency Approvals:	CCSA US	Mounting Arrangement:	F1
	CSA EEV	Power Factor:	79
	UR	Product Family:	Chem Process S/P 32-8 IEEE 841
Auxillary Box:	No Auxillary Box	Pulley End Bearing Type:	Ball
Auxillary Box Lead Termination:	None	Pulley Face Code:	C-Face
Base Indicator:	Rigid	Pulley Shaft Indicator:	Standard
Bearing Grease Type:	Polyrex EM (-20F +300F)	Rodent Screen:	None
Blower:	None	Shaft Extension Location:	Pulley End
Constant Torque Speed Range:	1	Shaft Ground Indicator:	No Shaft Grounding

Current @ Voltage:	32.000 A @ 460.0 V	Shaft Rotation:	Reversible
Design Code:	B	Shaft Slinger Indicator:	No Slinger
Drip Cover:	No Drip Cover	Speed Code:	Single Speed
Duty Rating:	CONT	Motor Standards:	NEMA
Electrically Isolated Bearing:	Not Electrically Isolated	Starting Method:	Direct on line
Enclosure Modification:	841	Thermal Device - Bearing:	None
Feedback Device:	NO FEEDBACK	Thermal Device - Winding:	None
Front Face Code:	Standard	Vibration Sensor Indicator:	No Vibration Sensor
Front Shaft Indicator:	None	Winding Thermal 1:	None
Heater Indicator:	No Heater	Winding Thermal 2:	None
Insulation Class:	F	XP Temp Code:	T3

Nameplate NP3190												
STK.NO.	CECP84111T-4		P/N			ENCLOSURE	TEFC					
SPEC.	12-0000-0417		CC	010A	FRAME	324TC		S/N				
HP	25		CLASS	F	HZ	60		ODE BRG	6312	DE BRG	6312	
RPM	1180	RPM MAX	1800		PH	3	DES	B		D.E. BRG.	60BC03X30X	
VOLT	460		KVA-CODE	G		O.D.E. BRG.	60BC03X30X					
AMP	32		MOTOR WEIGHT	640		GREASE	POLYREX EM					
RATING	40C AMB-CONT		MAX. KVAR	9		BLANK						
NEMA-NOM-EFF	93	# OF ROTOR BARS	42		SER.F.	1.15		IP	56			
G.MIN.EFF	91.7	# OF STATOR SLOTS	54		PF	79		INV.TYPE	PWM			
TEMP CODE	T3		INVERTER-TEMP-CODE	200								
TEMP =	200		C HP FR	60		C HP TO	90					
CT HZ FROM	1		CT HZ TO	60								
HTR-VOLTS			HTR-AMPS			HTR-WATTS			MAX. SPACE HEATER TEMP.			
									VT HZ FROM	O	VT HZ TO	60

Parts List		
Part Number	Description	Quantity
SA365060	SA 12-0000-0417	1.000 EA
RA354431	RA 12-0000-0417	1.000 EA
LB1115N	LABEL,LIFTING DEVICE (ON ROLLS)	1.000 EA
LB1119N	WARNING LABEL	1.000 EA
LC0006	CONNECTION LABEL	1.000 EA
LB1449	DIV-2/NEC WARNING LABEL	1.000 EA
NP3190	SS IEEE841 INV DIV-2 UL CSA-C US EEV	1.000 EA
85XU0407S04	4X1/4 U DRIVE PIN STAINLESS	4.000 EA
MN416A01	TAG-INSTAL-MAINT no wire (2100/bx) 4/22	1.000 EA
WD1000B48	T&B D73, RING TERMINAL 8 AWG 3/8 STUD	3.000 EA
WD1000B19	TERMINAL BURNDY L250HP	1.000 EA
HW1001A38	LOCKWASHER 3/8, ZINC PLT .688 OD, .382 I	1.000 EA
80XN3816A12	SET SCREW,HEX SOCKET CUP POINT,3/8-16 X	4.000 EA
12FH1002A15GP6	FAN COVER, MACH, W/PRIMER W/MG1025N19	1.000 EA
HW1001A50	LOCKWASHER 1/2, ZINC PLT,.879 OD, .509 I	4.000 EA
XY5013A12	NUT,1/2-13,HEX,STEEL,ZINCPLATED	4.000 EA
09FN3001B03SP	EXTERNAL FAN, PLASTIC (COMES W/SCREW FRO	1.000 EA
HW2500A25	WOODRUFF KEY USA #1008 #BLOW CARBON STEE	1.000 EA
MJ1000A02	GREASE, MOBIL POLYREX EM - 124047	0.200 LB
10XN3816K08	3/8-16 X .50 HEX HD CAP SCREW GRADE 5	1.000 EA
12EP1111A02GP6	FR ENDPLATE, MACH W/EPOXY PRIMER & RELIA	1.000 EA
HA3400A32	STUD, 1/2-13 X 7.38	4.000 EA
HW1001A50	LOCKWASHER 1/2, ZINC PLT,.879 OD, .509 I	4.000 EA
HW4601A55	INPRO/SEAL #1698-A-M0022-0 VBXX 312 BRG/	1.000 EA

Parts List (continued)		
Part Number	Description	Quantity
HW5100A15	W4997-050 WVY WSHR (WB)	1.000 EA
HW4500A20	1/8NPT SL PIPE PLUG	1.000 EA
HA4017A02	.125X2.50 GREASER EXTENS.F/S	1.000 EA
HA4017A01	1/8 X 4 GREASE EXT (F/S)	1.000 EA
HW4019A01	PIPE COUPLING 1/8 NPT,STEEL,ZINC COATING	1.000 EA
10XN3118K40	5/16-18 X 2.50" HEX HD, GRADE 5	4.000 EA
HA4051A00	PLASTIC CAP FOR GREASE FITTING	1.000 EA
HW4500A21	1618BALEMITE FITTING 825 UNIVERSAL	1.000 EA
HW4500A17	317400 ALEMITE GREASE RELIEF	1.000 EA
HA4002A03	#304 S.S. DRAIN FITTING, .125 NPT (.44 H	1.000 EA
HA4002A03	#304 S.S. DRAIN FITTING, .125 NPT (.44 H	1.000 EA
12EP1105A99P	PU EP, MACH, PLS, INPRO W/EPOXY PRIMER	1.000 EA
HW1001A50	LOCKWASHER 1/2, ZINC PLT.,.879 OD, .509 I	4.000 EA
10XN5013K28	1/2-13 X 1.75 HEX HEAD MACH SCREW,GRAD	4.000 EA
HW4601A55	INPRO/SEAL #1698-A-M0022-0 VBXX 312 BRG/	1.000 EA
HW4500A20	1/8NPT SL PIPE PLUG	1.000 EA
10XN3118K40	5/16-18 X 2.50" HEX HD, GRADE 5	4.000 EA
HA4051A00	PLASTIC CAP FOR GREASE FITTING	1.000 EA
HW4500A03	GREASE FITTING, .125 NPT 1610(ALEMITE) 8	1.000 EA
HW4500A17	317400 ALEMITE GREASE RELIEF	1.000 EA
10CB1000A04P	KO BOX, MACH W/2.00 NPT W/EPOXY PRIMER	1.000 EA
09GS1010	GASKET, DWG, LEADWIRE SEPERATOR	1.000 EA
10XN3118K16	5/16-18 X 1' GRADE #5, STL, ZINC PLATE	4.000 EA
HW1001A31	LOCKWASHER 5/16, ZINC PLT.591 OD, .319 I	4.000 EA

Product Information Packet: CECP84111T-4 - 25HP,1180RPM,3PH,60HZ,324TC,TEFC,F1

WD1000B16	T&B CX70TN OR L70P TERMINAL LUG	1.000 EA
59XW2520G07	.25-20X.44,HEX SER WSHR,TAPTITE 2,GREEN	1.000 EA
10CB1503A01P	CONDUIT BOX LIPPED LID, MACH W/EPXY PRMR	1.000 EA
14GS1003	GASKET CONDUIT BOX LID, NEOP	1.000 EA
10XN2520K16	1/4-20 X 1" HX HD SCRW GRADE 5, ZINC P	4.000 EA
HW1001A25	LOCKWASHER 1/4, ZINC PLT .493 OD, .255 I	4.000 EA
MG1025N19	WILKOFAS, 778.50, RELIANCE BLUE-GREEN	0.125 GA
MJ5001A27	32220KN GRAY SEALER *MIN BUY 4 QTS=1GAL	0.031 QT
MJ5001A14	DYNAPRO SEALANT, CP MTR VC#2508050 (603	0.033 EA
MJ5002A01	SILICON RUBBER SEALANT, 732CL 10.3 OZ TU	0.025 EA
12PA1000	PACKAGING GROUP PRINT PK1024A07	1.000 EA
HW2501H33	KEY, 1/2 SQ X 3.875	1.000 EA
MJ5004A59	ADHESIVE LOCTITE #401 SURFACE INSENSITIV	0.010 EA

AC Induction Motor Performance Data

Record # 47214

Typical performance - not guaranteed values

Winding: 12WGY445-R012		Type: 1264M	Enclosure: TEFC
Nameplate Data		460 V, 60 Hz: Single Voltage Motor	
Rated Output (HP)	25	Full Load Torque	111 LB-FT
Volts	460	Start Configuration	direct on line
Full Load Amps	32	Breakdown Torque	283 LB-FT
R.P.M.	1180	Pull-up Torque	131 LB-FT
Hz	60 Phase	Locked-rotor Torque	156 LB-FT
NEMA Design Code	B KVA Code	Starting Current	178 A
Service Factor (S.F.)	1.15	No-load Current	12.4 A
NEMA Nom. Eff.	93 Power Factor	Line-line Res. @ 25°C	0.29206 Ω
Rating - Duty	40C AMB-CONT	Temp. Rise @ Rated Load	48°C
S.F. Amps		Temp. Rise @ S.F. Load	60°C
		Locked-rotor Power Factor	27.6
		Rotor inertia	12.2 LB-FT ²

Load Characteristics 460 V, 60 Hz, 25 HP

% of Rated Load	25	50	75	100	125	150	S.F.
Power Factor	47	67	76	79	81	81	80
Efficiency	90.3	93.2	93.6	93.2	92.3	91	92.7
Speed	1194.5	1190.4	1185.5	1180.1	1173.8	1165.5	1176
Line amperes	14.4	19	24.7	31.6	39.1	48.1	36.1

Performance Graph at 460V, 60Hz, 25.0HP Typical performance - Not guaranteed values

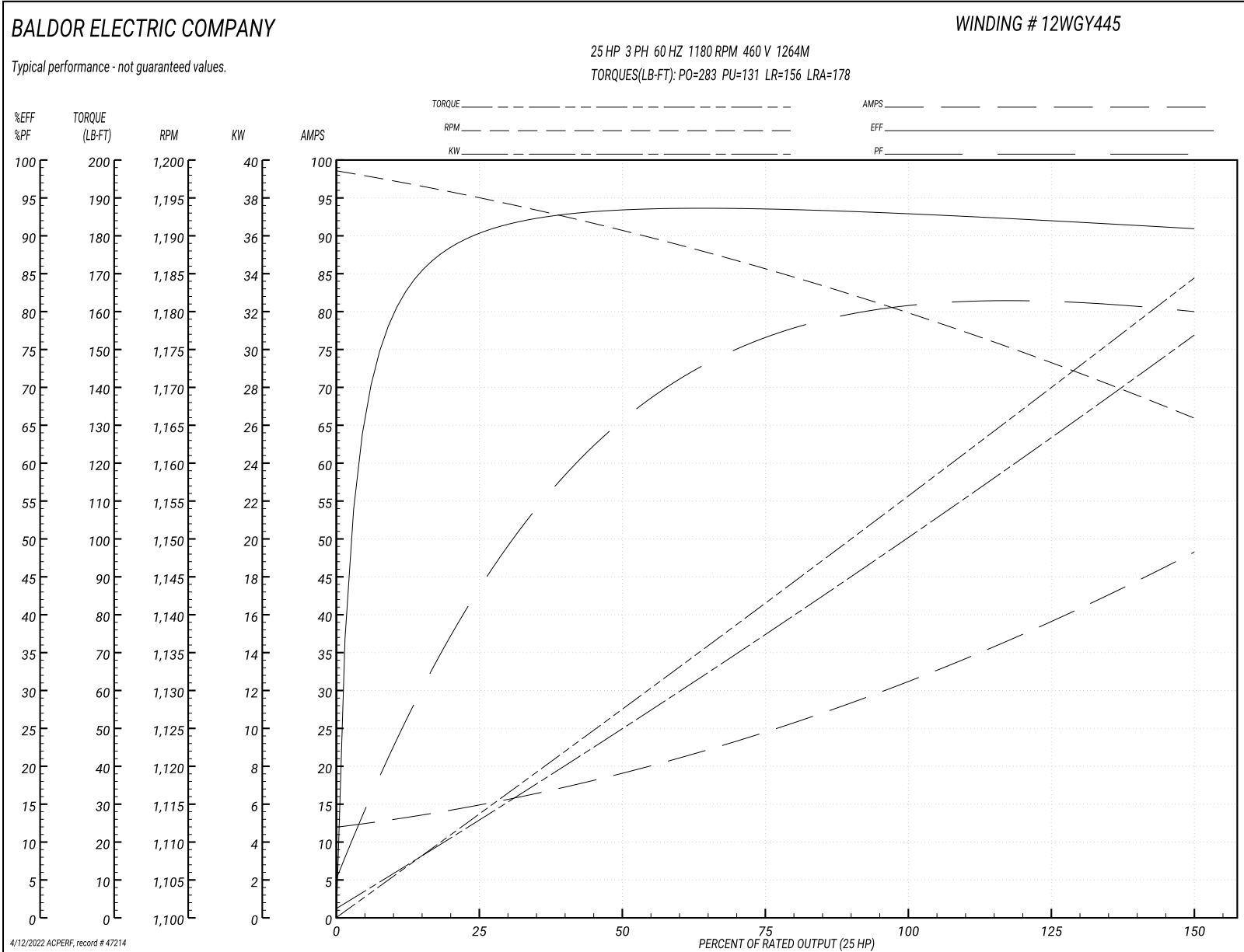

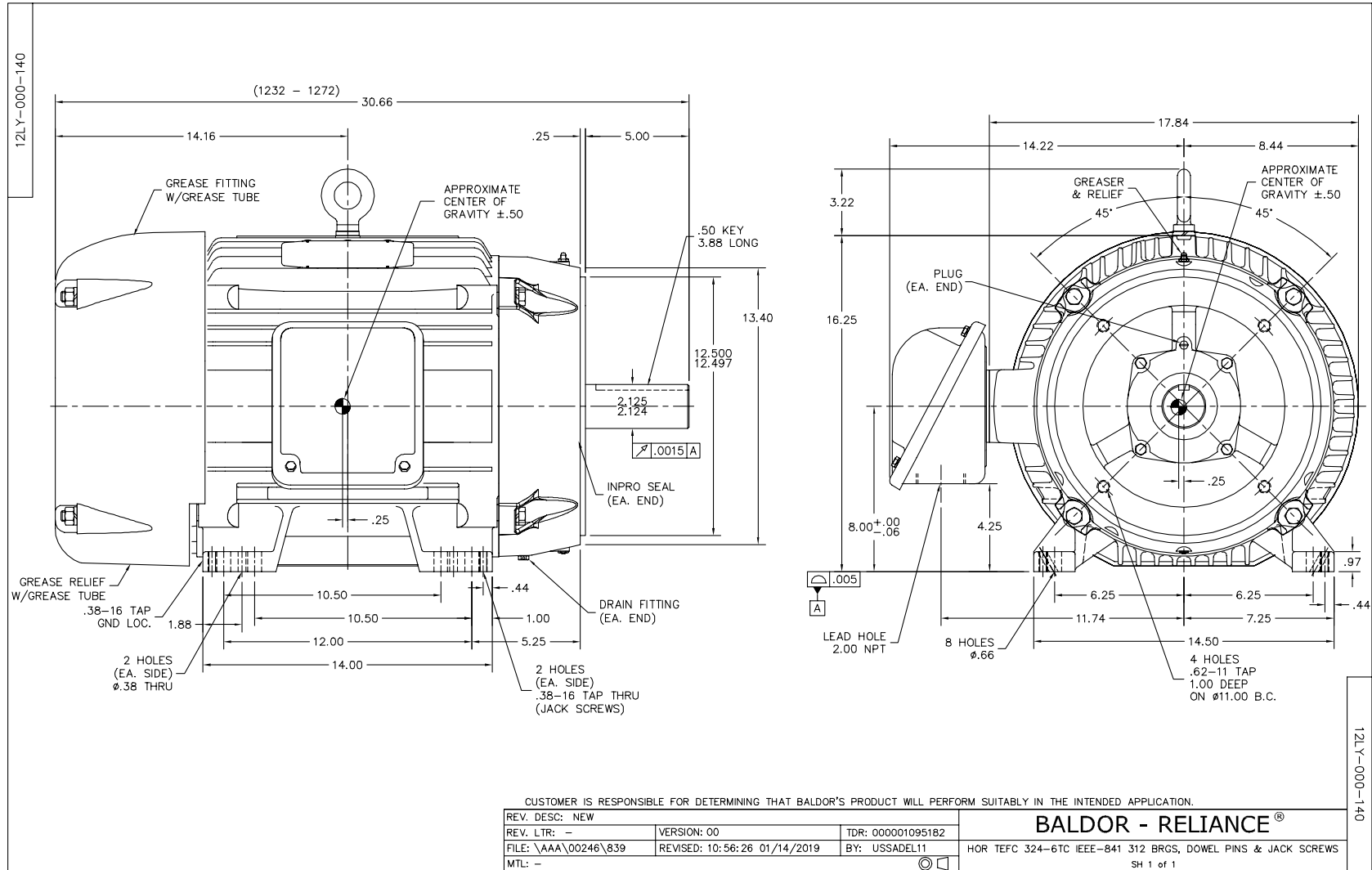

CD0006



NOTES:

1. THREE LEAD MOTOR MAY BE EITHER WYE CONNECTED OR DELTA CONNECTED.
2. INTERCHANGE ANY TWO LINE LEADS TO REVERSE ROTATION.
3. OPTIONAL THERMOSTATS ARE PROVIDED WHEN SPECIFIED.
4. ACTUAL NUMBER OF INTERNAL PARALLEL CIRCUITS MAY VARY.
5. LEAD COLORS ARE OPTIONAL. LEADS MUST BE NUMBERED AS SHOWN.

CD0006

REV. DESC: ADD CLASS CONN00000007		
REV. LTR: E	VERSION: 01	TDR: 000001099922
FILE: \AAA\00005\141	REVISED: 10:24:49 02/19/2019	BY: ENBRIRO
MTL: -	© □	

BALDOR - RELIANCE®

3PH, SV, 3 LEADS, WYE OR DELTA CONNECTED

SH 1 of 1

Marketing maintained PDF of MN416:

<http://www.baldor.com/support/Literature/Load.ashx/MN416?ManNumber=MN416>