

**BALDOR • RELIANCE**

---

# Customer information packet

## CECP84312T-4

50HP, 1185RPM, 3PH, 60HZ, 365TC, A36062M, TEFC

Class - None

Division - Division II

## Specifications

Enclosure	TEFC
Frame	365TC
Frame Material	Iron
Frequency	60.00 Hz
Motor Letter Type	Three Phase
Output @ Frequency	50.000 HP @ 60 HZ
Phase	3
Synchronous Speed @ Frequency	1200 RPM @ 60 HZ
Voltage @ Frequency	460.0 V @ 60 HZ
XP Class and Group	None
XP Division	Division II
Agency Approvals	UR CCSA US
Ambient Temperature	40 °C
Auxillary Box	No Auxillary Box
Base Indicator	Rigid
Bearing Grease Type	Polyrex EM (-20F +300F)
Constant Torque Speed Range	6-60
Current @ Voltage	61.700 A @ 460.0 V
Design Code	B
Drip Cover	No Drip Cover
Duty Rating	CONT
Efficiency @ 100% Load	94.1 %
Enclosure Modification	841
Feedback Device	NO FEEDBACK
Heater Indicator	No Heater
High Voltage Full Load Amps	61.7 a
Insulation Class	B
Inverter Code	Inverter Ready
IP Rating	IP56
KVA Code	F
Lifting Lugs	Standard Lifting Lugs

## Part detail

Revision	E
Type	AC
Mech. spec.	
Base	
Status	PRD/A
Elec. spec.	A36WG0777
Layout	617428-620
Eff. date	09-29-2021
CD Diagram	416820-036
Poles	06
Leads	3#4
Proprietary	False
Created date	01-03-2019

<b>Motor Lead Quantity/Wire Size</b>	3 @ 4 AWG
<b>Motor Standards</b>	NEMA
<b>Motor Type</b>	A36062M
<b>Mounting Arrangement</b>	F1
<b>No Load Current</b>	20.8 a
<b>Number of Poles</b>	6
<b>Overall Length</b>	33.48 IN
<b>Power Factor</b>	81
<b>Product Family</b>	General Industrial
<b>Pulley End Bearing Type</b>	Ball
<b>Pulley Face Code</b>	C-Face
<b>Service Factor</b>	1.15
<b>Shaft Diameter</b>	2.374 IN
<b>Shaft Ground Indicator</b>	No Shaft Grounding
<b>Shaft Rotation</b>	Reversible
<b>Shaft Slinger Indicator</b>	No Slinger
<b>Speed</b>	1185 rpm
<b>Speed Code</b>	Single Speed
<b>Starting Method</b>	Direct on line
<b>Thermal Device - Winding</b>	None
<b>XP Temp Code</b>	T3A

**Nameplate**

---

NP2496L	
MOBIL POLYREX EM	

---

---

**000613007EX**

---

<b>CAT NO</b>	CECP84312T-4	<b>SPEC NO.</b>	A36-7237-0777
<b>NO. ROTOR BARS</b>	55	<b>GREASE TYPE</b>	POLYREX EM
<b>NO. SLOTS</b>	72	<b>NL AMPS AT RATED VOLTAGE</b>	20.8
<b>5 YEAR WARRANTY</b>		<b>WINDING RES @25 C</b>	.12973 <b>OHMS</b>
<b>MFG. DATE</b>		<b>SER.NO</b>	

---

**NP3237**

<b>CAT NO</b>	CECP84312T-4	<b>SPEC NO.</b>	A36-7237-0777						
<b>HP</b>	50	<b>AMPS</b>	61.7	<b>VOLTS</b>	460	<b>DESIGN</b>	B		
<b>FRAME SIZE</b>	365TC	<b>RPM</b>	1185	<b>HZ</b>	60	<b>AMB</b>	40	<b>SF</b>	1.15
<b>D.E. BRG.DATA</b>	6313	<b>O.D.E. BRG.DATA</b>	6313	<b>PH</b>	3	<b>DUTY</b>	CONT	<b>INSUL.CLASS</b>	B
<b>D.E. BRG.</b>	65BC03J30X	<b>TYPE P</b>	P	<b>ENCL</b>	TEFC	<b>CODE</b>	F		
<b>O.D.E. BRG.</b>	65BC03J30X	<b>POWER FACTOR</b>	81	<b>NEMA-NOM-EFFICIENCY</b>	94.1				
<b>3/4 LOAD EFF.</b>	94.4	<b>IP</b>	56	<b>MAX CORR KVAR</b>	14	<b>GUARANTEED EFFICIENCY</b>	93		
<b>TEMP CODE</b>	T3A	<b>TEMP =</b>	180						
<b>CHP HZ</b>	60-90	<b>CT HZ</b>	6-60	<b>VT HZ</b>	0-60				
<b>INVERTER-TEMP-CODE</b>	T3A								
<b>SER.NO.</b>		<b>MOTOR WEIGHT</b>	925						

## Parts list

Part number	Description	Quantity
SA364599	SA A36-7237-0777	1.000 ea
RA353933	RA A36-7237-0777	1.000 ea
421948051	LABEL, MYLAR	1.000 ea
NP2496L	MOTOR LUBE NAMEPLATE	1.000 ea
000613006PU	N/P (RELEASE QTY 10,000) UL CSA LABEL	1.000 ea
000613007EX	SS IEEE 841 EMBOSSED AUXILIARY NAMEPLATE	1.000 ea
000692000JP	N/P	1.000 ea
000692000VH	N/P (RELEASE 1000 PCS)	1.000 ea
000692000VD	LABEL WARNING	1.000 ea
NP3237	SS SUPER E INVERTER DUTY IEEE 841	1.000 ea
085922083BH	BRKT 360 085922072WCC KB	1.000 ea
415072001B	CLAMP	1.000 ea
078559034A	+F/C A 078559001A - 360	1.000 ea
034180012DA	KEY 1X4X1/4X1-1/2 L	1.000 ea
412118006A	DRAIN	1.000 ea
078550001M	FAN KB 60/30 (30) 360	1.000 ea
004824015A	GREASE POLYREX EM	0.540 lb
032018012DK	HHCS 1/2-13X1-1/2 PLTD. 032018012DR	4.000 ea
032018008AK	HHCS 1/4-20X1 PLATED	4.000 ea
032018024CK	HHCS 3/8-16X3 PLTD.	3.000 ea
415096002A	CPLG 1/8 HEX TYPE	1.000 ea
410700004F	WSHR	1.000 ea
423709011C	WASHER	3.000 ea
035000001G	GREASE RELIEF FITTING, ALEMITE 317400	1.000 ea
034530052AB	P/NIP 1/8X6-1/2 Zinc	1.000 ea
034530032BB	P/NIP 1/4X4" SCHED 40	1.000 ea
034630002AB	CPLG 1/4" PLATED	1.000 ea
415028079E	INPRO SEAL,,625 WIDE,313 BRG	1.000 ea
034600001AA	BUSH 1/4TO1/8 BLACK	1.000 ea
034600001AA	BUSH 1/4TO1/8 BLACK	1.000 ea
085922070HA	E360 C FACE BRKT 6313 TEFC-4.64"-INPRO	1.000 ea

032018012DK	HHCS 1/2-13X1-1/2 PLTD. 032018012DR	4.000 ea
032018024CK	HHCS 3/8-16X3 PLTD.	3.000 ea
412118006A	DRAIN	1.000 ea
423709011C	WASHER	3.000 ea
415028079E	INPRO SEAL,,625 WIDE,313 BRG	1.000 ea
035000001G	GREASE RELIEF FITTING, ALEMITE 317400	1.000 ea
076708000BB	CONDUIT BOX-360	1.000 ea
415039016A	TERBD, 360-400	1.000 ea
076709000A	C/B Cover - 360	1.000 ea
067053000B	GASK 320-400	1.000 ea
418150003A	GREASE FITTING CAP	1.000 ea
032018010CK	HHCS 3/8-16X1-1/4 PLTD. 032018010CR	4.000 ea
035000001A	ALFTG 1/8" 1610-BL	1.000 ea
415000115H	T/LUG #2AWG-4/0AWG	1.000 ea
033512008LB	HHTTS 1/4-20X1 PLATED	4.000 ea
406099000A	PLUG - FAN COVER 320-440	1.000 ea
034000014AB	WSH ID.406 OD.812 TH.065	4.000 ea
035000001A	ALFTG 1/8" 1610-BL	1.000 ea
418150003A	GREASE FITTING CAP	1.000 ea
MG1025N19	WILKO 778.50 BLUE GREEN - 55 GAL DRUMS	0.250 ga
033775004EA	DRSCR #6-1/4 304 S.S.	4.000 ea
034180034HA	KEY 5/8X5/8X4-1/4 L	1.000 ea
HW1000A32	5/16 FL WASHER WIDE,ID=.344,OD=1.125	3.000 ea
032509020C	CARRIAGE BOLT - 360	3.000 ea
LB1449	DIV-2/NEC WARNING LABEL	1.000 ea
14PA1000	PACKAGING 314 GROUP COMBINED PRINT	1.000 ea
032018005DL	1/2-13 X 5/8 SILICON BRONZE HHCS	1.000 ea



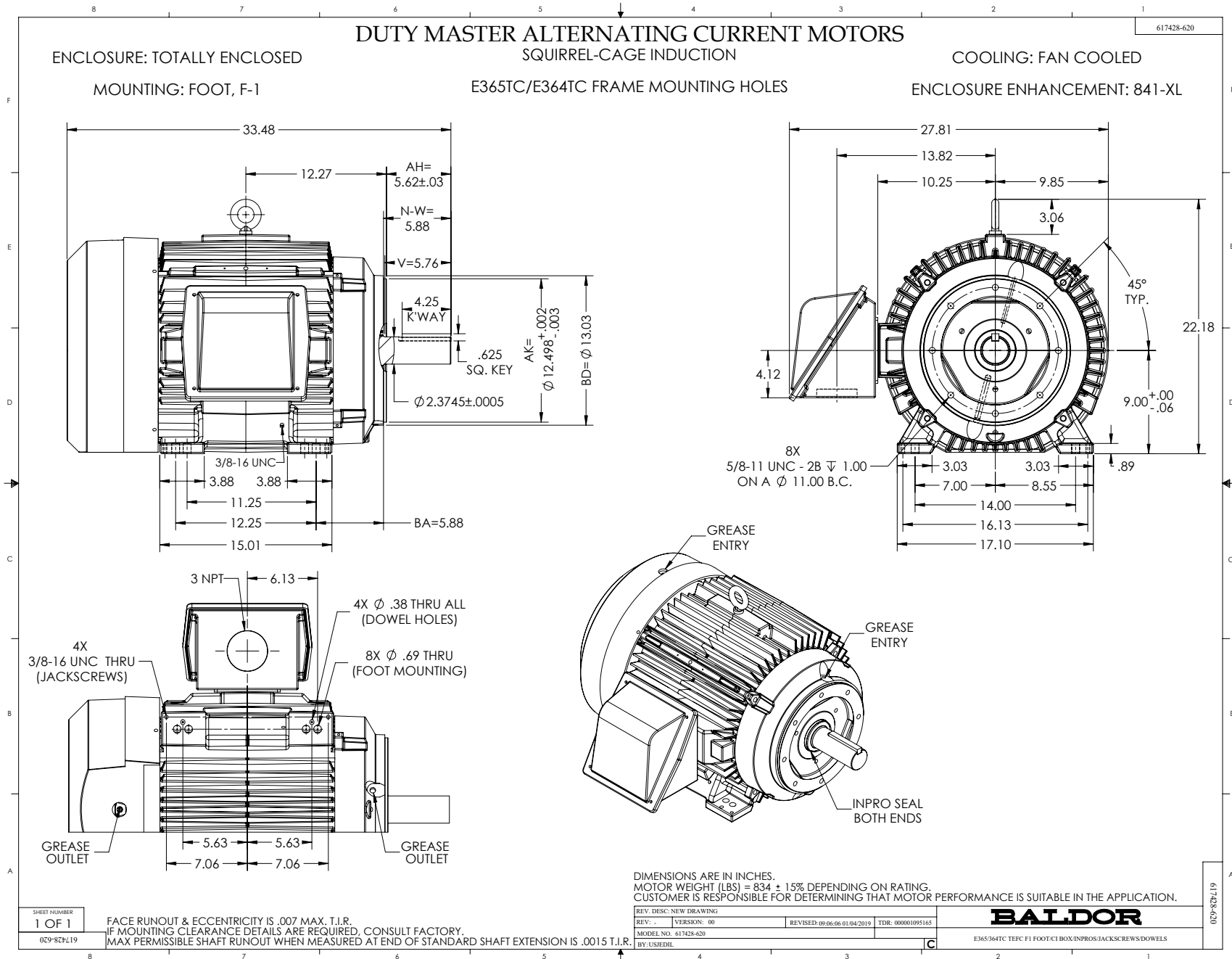

416820-036

A-C MOTOR  
CONNECTION DIAGRAM  
STANDARD 3 LEAD CONNECTED



(N.P. 1575-BA)

REV. DESC: LOADED TO BUS, C/R 335225		
REV. LTR: -	VERSION: 00	TDR: 000000538207
FILE: \MGA\00000\682	REVISED: 11:54:06 04/30/2010	
MTL: -	BY: RAGRA	

**BALDOR**

CONN DIAG - STANDARD 3 LEAD  
SH 1 of 1

416820-036