

BALDOR® • RELIANCE 

Product Information Packet

CECR9404T

40HP, 1775RPM, 3PH, 60HZ, 324T, TEFC, F1

Part Detail							
Revision:	C	Status:	PRD/A	Change #:		Proprietary:	No
Type:	AC	Elec. Spec:	12WGY872	CD Diagram:	CD0005	Mfg Plant:	
Mech. Spec:	12H992	Layout:	12LYH992	Poles:	04	Created Date:	02-21-2019
Base:	RG	Eff. Date:	04-09-2021	Leads:	9#8		

Specs			
Catalog Number:	CECR9404T	Front Shaft Indicator:	None
Enclosure:	TEFC	Heater Indicator:	No Heater
Frame:	324TC	Insulation Class:	F
Frame Material:	Iron	Inverter Code:	Inverter Duty
Output @ Frequency:	40.000 HP @ 60 HZ	IP Rating:	IP55
Synchronous Speed @ Frequency:	1800 RPM @ 60 HZ	KVA Code:	G
Voltage @ Frequency:	460.0 V @ 60 HZ	Lifting Lugs:	Standard Lifting Lugs
	230.0 V @ 60 HZ	Locked Bearing Indicator:	Locked Bearing
XP Class and Group:	None	Motor Lead Quantity/Wire Size:	9 @ 8 AWG
XP Division:	Not Applicable	Motor Lead Termination:	Flying Leads
Agency Approvals:	CSA	Motor Type:	1264M
	CSA EEV	Mounting Arrangement:	F1
	UR	Power Factor:	81
Auxillary Box:	No Auxillary Box	Product Family:	Super-E Chemical Processing
Auxillary Box Lead Termination:	None	Pulley End Bearing Type:	Ball
Base Indicator:	Rigid	Pulley Face Code:	Standard
Bearing Grease Type:	Polyrex EM (-20F +300F)	Pulley Shaft Indicator:	Standard
Blower:	None	Rodent Screen:	None

Constant Torque Speed Range:	6	Shaft Ground Indicator:	No Shaft Grounding
Current @ Voltage:	98.000 A @ 230.0 V	Shaft Rotation:	Reversible
	49.000 A @ 460.0 V	Shaft Slinger Indicator:	Shaft Slinger
	106.000 A @ 208.0 V	Speed Code:	Single Speed
Design Code:	A	Motor Standards:	NEMA
Drip Cover:	No Drip Cover	Starting Method:	Direct on line
Duty Rating:	CONT	Thermal Device - Bearing:	None
Electrically Isolated Bearing:	Not Electrically Isolated	Thermal Device - Winding:	None
Enclosure Modification:	Severe Duty Features	Vibration Sensor Indicator:	No Vibration Sensor
Feedback Device:	NO FEEDBACK	Winding Thermal 1:	None
		Winding Thermal 2:	None

Nameplate NP3293													
CAT.NO.	CECR9404T			P/N				ENCLOSURE	TEFC				
SPEC.	12H992Y872G1		CC	010A	FRAME	324TC		S/N					
HP	40		CLASS	F	HZ	60		DES	A				
RPM	1775		RPM MAX	2700		PH	3		KVA-CODE	G			
VOLT	230/460			I.P.	55								
AMP	98/49			SER.F.	1.25		PF	81		ODE BRG	6312	DE BRG	6313
RATING	40C AMB-CONT			NEMA-NOM-EFF	94.1		GREASE	POLYREX EM					
HTR-VOLTS			HTR-AMPS			HTR-WATTS			INV.TYPE				
	SFA 122/61			C HP FR	60		C HP TO	90					
				CT HZ FROM	6		CT HZ TO	60					
				MOTOR WEIGHT	650		VT HZ FROM	6		VT HZ TO 60			

Parts List		
Part Number	Description	Quantity
SA366468	SA 12H992Y872G1	1.000 EA
RA355892	RA 12H992Y872G1	1.000 EA
09FN3001C03	EXTERNAL FAN, PLASTIC (COMES W/SCREW FRO	1.000 EA
10CB1000A203P	KOBX W/2.00 NPT & .31 GND MTG, EPOXY PRI	1.000 EA
09GS1010	GASKET, DWG, LEADWIRE SEPERATOR	1.000 EA
10XN3118K16	5/16-18 X 1' GRADE #5, STL, ZINC PLATE	4.000 EA
HW1001A31	LOCKWASHER 5/16, ZINC PLT.591 OD, .319 I	4.000 EA
WD1000B25	GND LUG, BURNDY L125HP OR T&B L125HP-BB	1.000 EA
19XW3118G08	.31-18X.50,HEX WSHR HD,TAPTITE 2,GREEN	1.000 EA
HW1001A31	LOCKWASHER 5/16, ZINC PLT.591 OD, .319 I	1.000 EA
HA4017A11	1/8 X 2.75 GREASE EXT (F/S)	1.000 EA
HW4019A01	PIPE COUPLING 1/8 NPT,STEEL,ZINC COATING	1.000 EA
HA4017A01	1/8 X 4 GREASE EXT (F/S)	1.000 EA
HW4500A20	1/8NPT SL PIPE PLUG	1.000 EA
HA3400A32	STUD, 1/2-13 X 7.38	4.000 EA
HW1001A50	LOCKWASHER 1/2, ZINC PLT.,.879 OD, .509 I	4.000 EA
HW4600B41	V-RING SLINGER 2.125 X 2.880 X 0.280	1.000 EA
HW5100A15	W4997-050 WVY WSHR (WB)	1.000 EA
10XN3118K40	5/16-18 X 2.50" HEX HD, GRADE 5	4.000 EA
10XN3816K48	3/8-16 X 3 HEX HD CAP SCREW,Z/P	4.000 EA
12EP1300A01P	PUEP 364-5TC W/313 BRG & EPOXY PRIMER	1.000 EA
10XN5013K28	1/2-13 X 1.75 HEX HEAD MACH SCREW,GRAD	4.000 EA
HW1001A50	LOCKWASHER 1/2, ZINC PLT.,.879 OD, .509 I	4.000 EA
HW4600B42	V-RING SLINGER 2.375 X 3.070 X .28 VITON	1.000 EA

Parts List (continued)		
Part Number	Description	Quantity
12FH1002A13P	FAN COVER, MACH W/EPOXY PRIMER	1.000 EA
XY5013A12	NUT,1/2-13,HEX,STEEL,ZINCPLATED	4.000 EA
HW1001A50	LOCKWASHER 1/2, ZINC PLT.,.879 OD, .509 I	4.000 EA
10CB1503A01P	CONDUIT BOX LIPPED LID, MACH W/EPXY PRMR	1.000 EA
14GS1003	GASKET CONDUIT BOX LID, NEOP	1.000 EA
10XN2520K16	1/4-20 X 1" HX HD SCRW GRADE 5, ZINC P	4.000 EA
HW1001A25	LOCKWASHER 1/4, ZINC PLT .493 OD, .255 I	4.000 EA
HW2501H33	KEY, 1/2 SQ X 3.875	1.000 EA
MJ5002A01	SILICON RUBBER SEALANT, 732CL 10.3 OZ TU	0.030 EA
MJ5001A27	32220KN GRAY SEALER *MIN BUY 4 QTS=1GAL	0.031 QT
MJ5002A01	SILICON RUBBER SEALANT, 732CL 10.3 OZ TU	0.025 EA
LB1115N	LABEL,LIFTING DEVICE (ON ROLLS)	1.000 EA
LB1002N	LABEL,MARINE DUTY (ON ROLLS)	1.000 EA
12EP1111A57PP44	FR ENDPLATE, MACH W/EPOXY PRIMER & PAINT	1.000 EA
HW4500A17	317400 ALEMITE GREASE RELIEF	1.000 EA
HW4500A21	1618BALEMITE FITTING 825 UNIVERSAL	1.000 EA
HA4054	SHORT T-DRAIN FITTING, .125" N.P.T.	1.000 EA
HA4051A00	PLASTIC CAP FOR GREASE FITTING	1.000 EA
MJ1000A02	GREASE, MOBIL POLYREX EM - 124047	0.200 LB
HW4500A17	317400 ALEMITE GREASE RELIEF	1.000 EA
HW4500A03	GREASE FITTING, .125 NPT 1610(ALEMITE) 8	1.000 EA
HA4054	SHORT T-DRAIN FITTING, .125" N.P.T.	1.000 EA
HA4051A00	PLASTIC CAP FOR GREASE FITTING	1.000 EA
HW2500A25	WOODRUFF KEY USA #1008 #BLOW CARBON STEE	1.000 EA

Product Information Packet: CECR9404T - 40HP,1775RPM,3PH,60HZ,324T,TEFC,F1

MG1025G96	WILKOFAST SG, 779.7048, MOUSE GRAY #7048	0.080 GA
85XU0407S04	4X1/4 U DRIVE PIN STAINLESS	4.000 EA
LB1119N	WARNING LABEL	1.000 EA
LC0005	CONN.DIA.,TY M,9-LD,DUAL VOLT,REVERSING	1.000 EA
NP3293	SS CRUSHER DUTY INV UL CSA-EEV PREM CC	1.000 EA
12PA1000	PACKAGING GROUP PRINT PK1024A07	1.000 EA
MN416A01	TAG-INSTAL-MAINT no wire (2100/bx) 4/22	1.000 EA

AC Induction Motor Performance Data

Record # 48603

Typical performance - not guaranteed values

Winding: 12WGY872-R001		Type: 1264M	Enclosure: TEFC
Nameplate Data		460 V, 60 Hz: High Voltage Connection	
Rated Output (HP)	40	Full Load Torque	118 LB-FT
Volts	230/460	Start Configuration	direct on line
Full Load Amps	98/49	Breakdown Torque	313 LB-FT
R.P.M.	1775	Pull-up Torque	202 LB-FT
Hz	60 Phase	Locked-rotor Torque	289 LB-FT
NEMA Design Code	A KVA Code	Starting Current	304 A
Service Factor (S.F.)	1.25	No-load Current	19.5 A
NEMA Nom. Eff.	94.1 Power Factor	Line-line Res. @ 25°C	0.14 Ω
Rating - Duty	40C AMB-CONT	Temp. Rise @ Rated Load	55°C
S.F. Amps	122/61	Temp. Rise @ S.F. Load	76°C
		Locked-rotor Power Factor	30
		Rotor inertia	8.49 LB-FT ²

Load Characteristics 460 V, 60 Hz, 40 HP

% of Rated Load	25	50	75	100	125	150	S.F.
Power Factor	46	67	77	81	82	82	82
Efficiency	89.8	93.7	94.3	94.2	93.4	93	93.6
Speed	1794	1790	1784	1779	1771	1763	1772
Line amperes	22.6	29.7	38.7	49.2	60.7	73.8	60.7

Performance Graph at 460V, 60Hz, 40.0HP Typical performance - Not guaranteed values

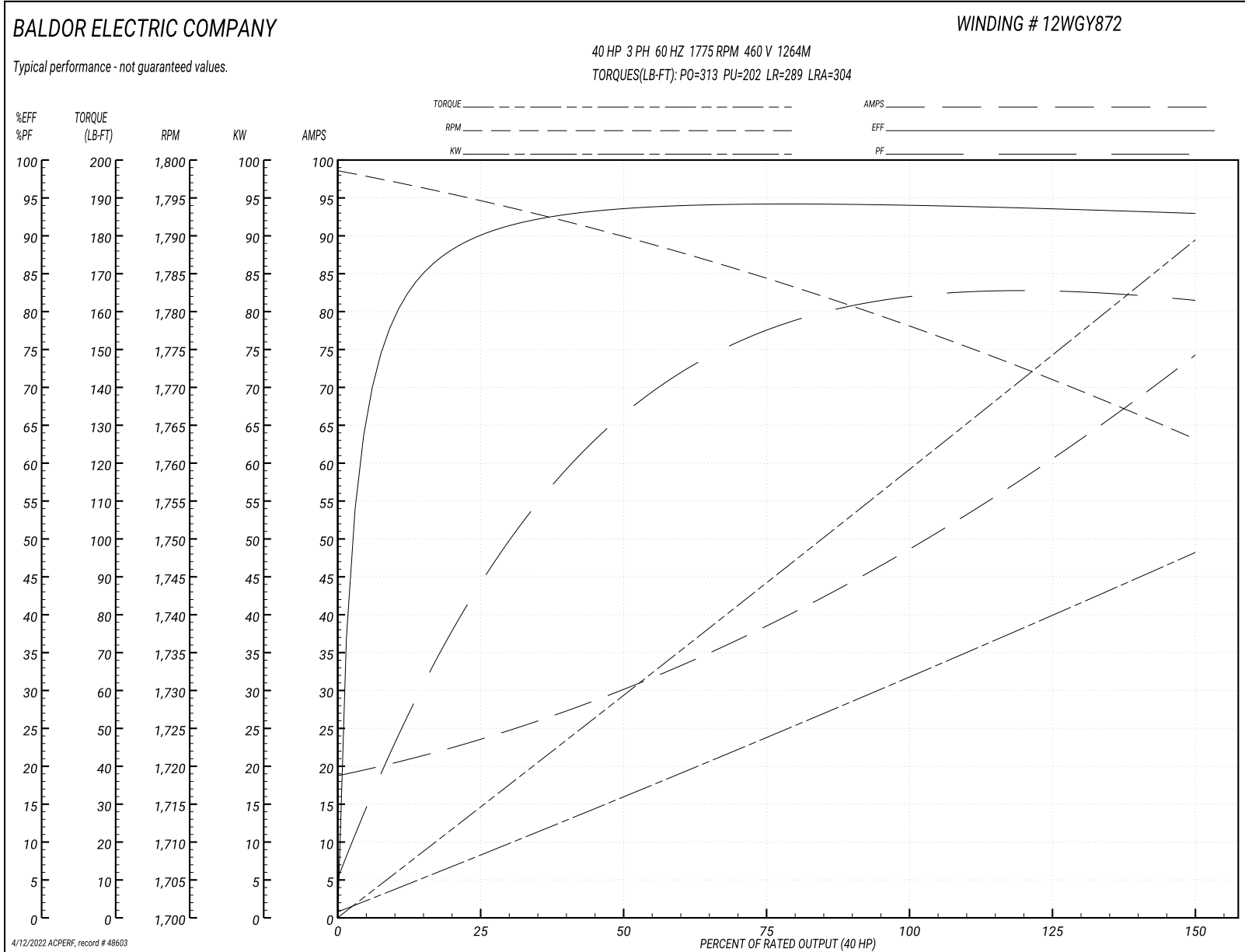

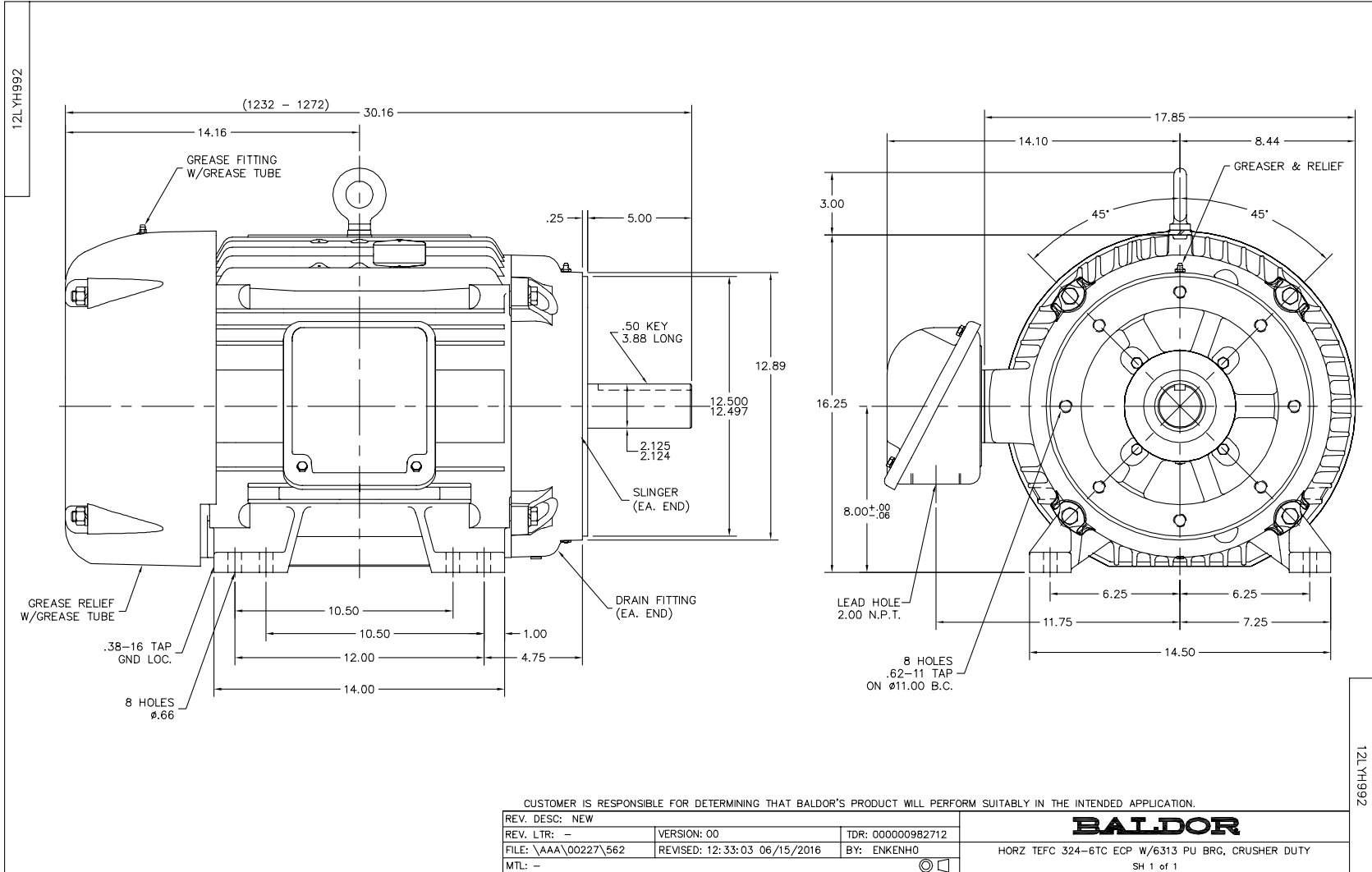

CD0005

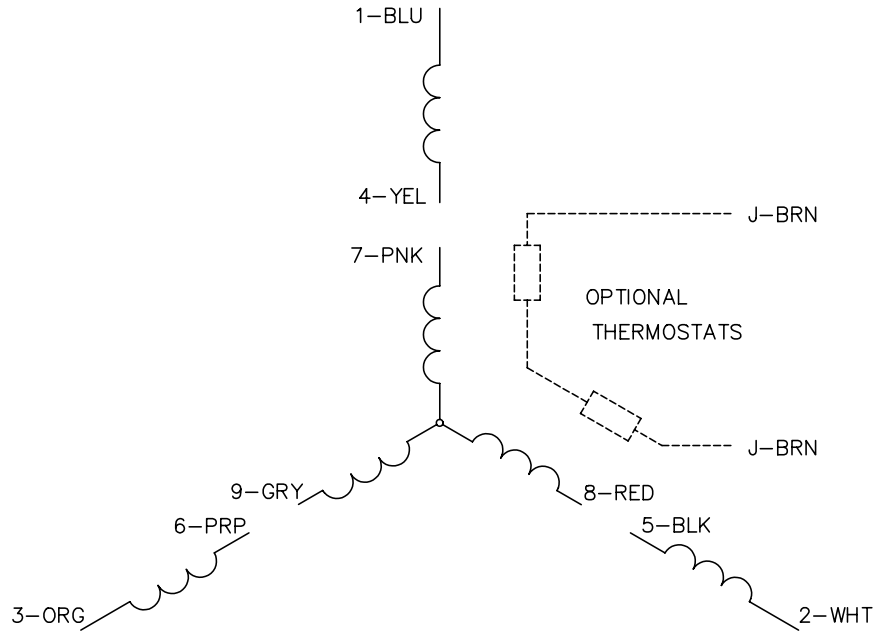

LOW VOLTAGE
(2Y)

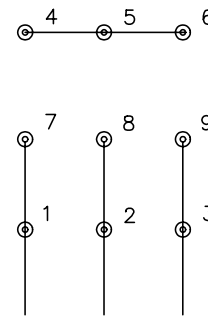

LINE

HIGH VOLTAGE
(1Y)

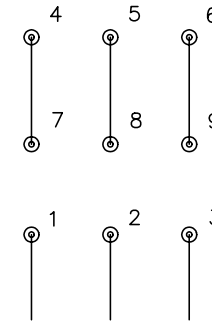

LINE

NOTES:

1. INTERCHANGE ANY TWO LINE LEADS TO REVERSE ROTATION.
2. OPTIONAL THERMOSTATS ARE PROVIDED WHEN SPECIFIED.
3. ACTUAL NUMBER OF INTERNAL PARALLEL CIRCUITS MAY BE A MULTIPLE OF THOSE SHOWN ABOVE.
4. LEAD COLORS ARE OPTIONAL. LEADS MUST ALWAYS BE NUMBERED AS SHOWN.

REV. DESC: REVISE TO SHOW OPTIONAL COLORS

REV. LTR: E BY: JLP

REVISED: 01/19/99 10:15

TDR: 0171435

900000

FILE: AAA00005140

MDL: -

MTL: -

BALDOR ELECTRIC Co.

3PH, DV, 9 LEADS

CD0005

Marketing maintained PDF of MN416:

<http://www.baldor.com/support/Literature/Load.ashx/MN416?ManNumber=MN416>