

BALDOR® • RELIANCE 

Product Information Packet

CEDM3709T

7.5HP,3520RPM,3PH,60HZ,213TC,3728M,TEFC

Part Detail							
Revision:	F	Status:	PRD/A	Change #:		Proprietary:	No
Type:	AC	Elec. Spec:	37WGR224	CD Diagram:	CD0005	Mfg Plant:	
Mech. Spec:	37N854	Layout:	37LYN854	Poles:	02	Created Date:	04-14-2016
Base:	RG	Eff. Date:	06-24-2021	Leads:	9#14		

Specs			
Catalog Number:	CEDM3709T	Heater Indicator:	No Heater
Enclosure:	TEFC	Insulation Class:	F
Frame:	213TC	Inverter Code:	Inverter Duty
Frame Material:	Steel	KVA Code:	J
Output @ Frequency:	7.500 HP @ 60 HZ	Lifting Lugs:	Standard Lifting Lugs
Synchronous Speed @ Frequency:	3600 RPM @ 60 HZ	Locked Bearing Indicator:	Locked Bearing
Voltage @ Frequency:	460.0 V @ 60 HZ	Motor Lead Quantity/Wire Size:	9 @ 14 AWG
	230.0 V @ 60 HZ	Motor Lead Exit:	Ko Box
XP Class and Group:	None	Motor Lead Termination:	Flying Leads
XP Division:	Not Applicable	Motor Type:	3728M
Agency Approvals:	UR	Mounting Arrangement:	F1
	CSA EEV	Power Factor:	84
	CCSA US	Product Family:	Dirty Duty Plus
Auxillary Box:	No Auxillary Box	Pulley End Bearing Type:	Sealed Bearing
Auxillary Box Lead Termination:	None	Pulley Face Code:	C-Face
Base Indicator:	Rigid	Pulley Shaft Indicator:	Standard
Bearing Grease Type:	Polyrex EM (-20F +300F)	Rodent Screen:	None
Blower:	None	RoHS Status:	ROHS COMPLIANT

Constant Torque Speed Range:	6	Shaft Extension Location:	Pulley End
Current @ Voltage:	18.000 A @ 230.0 V	Shaft Ground Indicator:	No Shaft Grounding
	19.000 A @ 208.0 V	Shaft Rotation:	Reversible
	9.000 A @ 460.0 V	Shaft Slinger Indicator:	No Slinger
Design Code:	A	Speed Code:	Single Speed
Drip Cover:	No Drip Cover	Motor Standards:	NEMA
Duty Rating:	CONT	Starting Method:	Direct on line
Electrically Isolated Bearing:	Not Electrically Isolated	Thermal Device - Bearing:	None
Feedback Device:	NO FEEDBACK	Thermal Device - Winding:	None
Front Face Code:	Standard	Vibration Sensor Indicator:	No Vibration Sensor
Front Shaft Indicator:	None	Winding Thermal 1:	None
		Winding Thermal 2:	None

Nameplate NP3504E												
CAT NO	CEDM3709T											
SPEC.	37N854R224G1						ENCL	TEFC				
FRAME	213TC			HP	7.5							
VOLTS	230/460											
FLA	18/9				I.P.	56						
RPM	3520			RPM MAX	5400							
HZ	60			PH	3		CLASS	F				
SER.F.	1.15			DES	A		CC	010A				
NEMA-NOM-EFF	89.5											
RATING	40C AMB-CONT											
DE BRG	6307			ODE BRG	6206							
GREASE	POLYREX EM											
C HP FR	60			C HP TO	90							
CT HZ FROM	6			CT HZ TO	60							
SER.NO												
	50C AT 1.0 SF											
							VT HZ FROM	6		VT HZ TO	60	

Parts List		
Part Number	Description	Quantity
SA319731	SA 37N854R224G1	1.000 EA
RA307440	RA 37N854R224G1	1.000 EA
HW3200A01	3/8-16X3/4 I-BLT WELDED F/S	1.000 EA
37CB1000A17E	37 KOBX .75 NPT @ 6:00 (E-COAT)	1.000 EA
37GS1016B01	SANTOPRENE KOBX GASKET W/LIP (BLACK)	1.000 EA
51XW2520A12	.25-20 X .75, TAPTITE II, HEX WSHR SLTD	2.000 EA
11XW1032G06	10-32 X .38, TAPTITE II, HEX WSHR SLTD U	1.000 EA
HW3001B01	BRASS CUP WASHER, FOR #10 SCREW	1.000 EA
37EP1100E37EP5	FRONT TEFC 206 BRG W/CLIPPER	1.000 EA
HA4054	SHORT T-DRAIN FITTING, .125" N.P.T.	1.000 EA
HW4606A03	JM CLIPPER/SEAL (LWE-1156-1875-AL44)	1.000 EA
HW4500S33	1/8 NPT STAINLESS #304 SS PLUG	3.000 EA
HW5100A06	W2420-025 WVY WSHR (WB)	1.000 EA
37EP1300B75E	PULLEY 213-5TC ENCL 307 BRG (E-COAT)	1.000 EA
HA4054	SHORT T-DRAIN FITTING, .125" N.P.T.	1.000 EA
HW4606A04	JM CLIPPER/SEAL (LWE-1376-2125-AL45)	1.000 EA
HW4500S33	1/8 NPT STAINLESS #304 SS PLUG	3.000 EA
10XN2520S28	1/4-20X 1 3/4 HEX HD SS X	4.000 EA
XY3118S12	5/16-18 HEX NUT, STAINLESS STEEL	4.000 EA
51XB1214A20	12-14X1.25 HXWSSLD SERTYB	1.000 EA
07FH4011EP5	FH CAST - POWDER COAT PRIMER 5 MILS	1.000 EA
10XN1032S08	10-32X1/2 HEX HEAD S STL	3.000 EA
36CB4518E	36 LIPPED CB LID E-COATING	1.000 EA
37GS1003	1/16 NEOPRENE GASKET-BLACK, CONDUIT BOX	1.000 EA

Parts List (continued)		
Part Number	Description	Quantity
59XN0832S07	8/32 X 7/16 HX WS HD SER X	4.000 EA
HW2502F21	#303 SS,SQ KEY 5/16 X 2.375	1.000 EA
HA7000A02	KEY RETAINER RING, 1 1/8 DIA, 1 3/8 DIA	1.000 EA
MJ5001A02	732 CL SEALANT 3 OZ DIXIE BEARING 289100	0.001 EA
85XU0407S04	4X1/4 U DRIVE PIN STAINLESS	2.000 EA
LB1115N	LABEL,LIFTING DEVICE (ON ROLLS)	1.000 EA
LB1164	LABEL,WARNING AND DRAIN	1.000 EA
MJ5001A23	P.D. GEORGE B-276 AIR DRY VARNISH	0.001 GA
LB1000	LABEL, DIRTY DUTY	1.000 EA
WD1000D21	TRM,T&B #B71M,RING,18-14,.25,NON-INSL	9.000 EA
MJ1000A02	GREASE, MOBIL POLYREX EM - 124047	0.050 LB
MG1500Y02	WILKOPON PRIMER YELLOW	0.010 GA
MG1025L01	WILKOFASFD, 786.04, BLACK	0.010 GA
36FN3000C02SP	EXFN, PLASTIC, 5.25 OD, 1.175 ID	1.000 EA
HA3104S14	300UBOLT 12.125LG SS	4.000 EA
LC0005	CONN.DIA.,TY M,9-LD,DUAL VOLT,REVERSING	1.000 EA
NP3504E	SS DIRTY DUTY PLUS INV UL CSA-C US EEV	1.000 EA
37PA1074	PALLET PACK GRP, PRINT BOX PK1026A06	1.000 EA
MN416A01	TAG-INSTAL-MAINT no wire (2100/bx) 4/22	1.000 EA

AC Induction Motor Performance Data

Record # 55732

Typical performance - not guaranteed values

Winding: 37WGR224-R038		Type: 3728M		Enclosure: TEFC	
Nameplate Data			460 V, 60 Hz: High Voltage Connection		
Rated Output (HP)	7.5	Full Load Torque		10.9 LB-FT	
Volts	230/460	Start Configuration		direct on line	
Full Load Amps	18/9	Breakdown Torque		40.4 LB-FT	
R.P.M.	3520	Pull-up Torque		20.6 LB-FT	
Hz	60 Phase	3	Locked-rotor Torque		21.8 LB-FT
NEMA Design Code	A KVA Code	J	Starting Current		68.4 A
Service Factor (S.F.)	1.15	No-load Current		3.73 A	
NEMA Nom. Eff.	89.5 Power Factor	84	Line-line Res. @ 25°C		1.1 Ω
Rating - Duty	40C AMB-CONT	Temp. Rise @ Rated Load		45°C	
S.F. Amps		Temp. Rise @ S.F. Load		55°C	
		Locked-rotor Power Factor		33	
		Rotor inertia		0.255 LB-FT ²	

Load Characteristics 460 V, 60 Hz, 7.5 HP

% of Rated Load	25	50	75	100	125	150	S.F.
Power Factor	45	69	79	84	87	89	86
Efficiency	81.5	88.8	90.5	90.7	90.2	89.4	90.3
Speed	3581	3563	3542	3520	3496	3471	3506
Line amperes	4.22	5.36	7.03	8.94	11	13.1	10.2

Performance Graph at 460V, 60Hz, 7.5HP Typical performance - Not guaranteed values

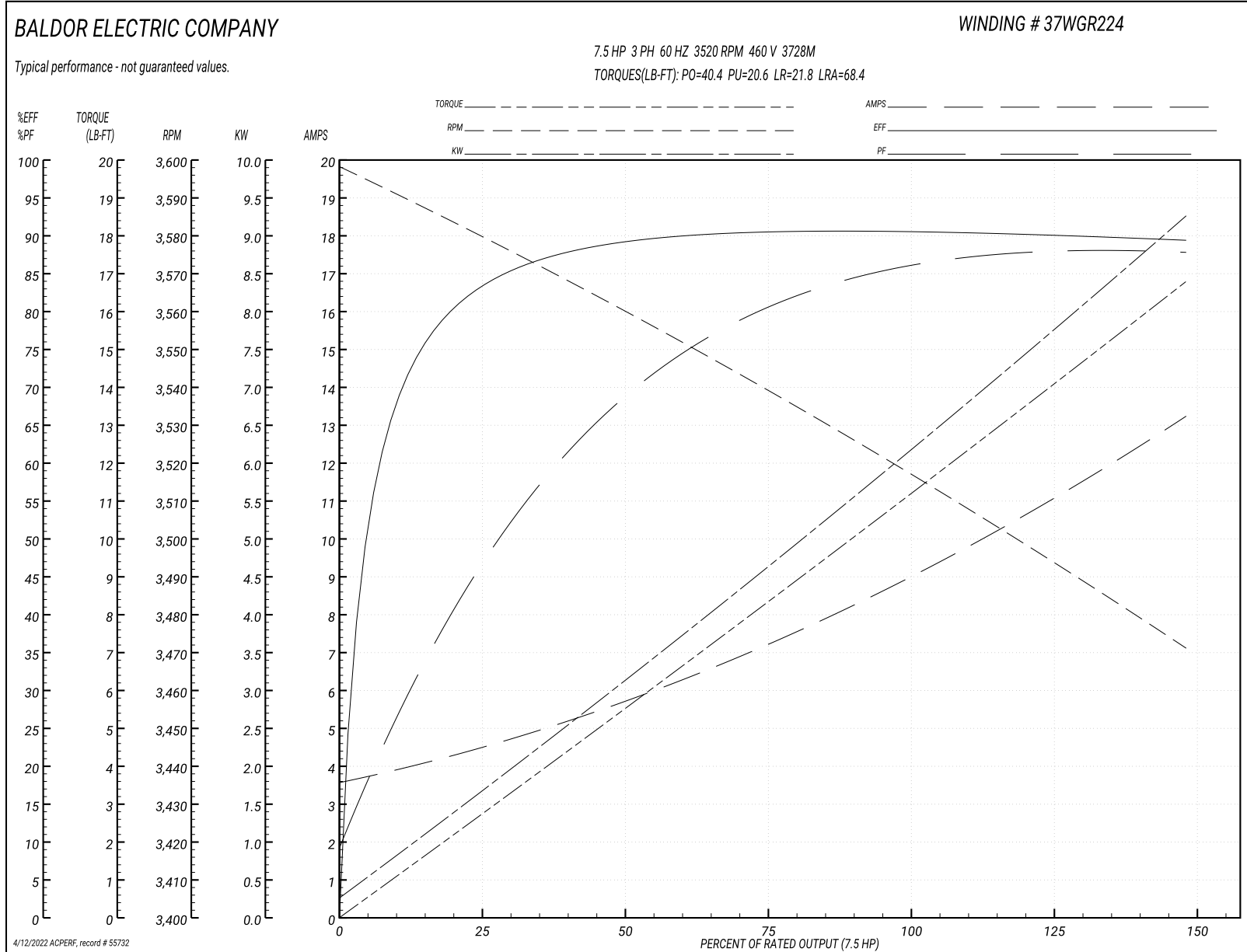

37LYN854

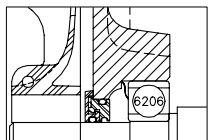
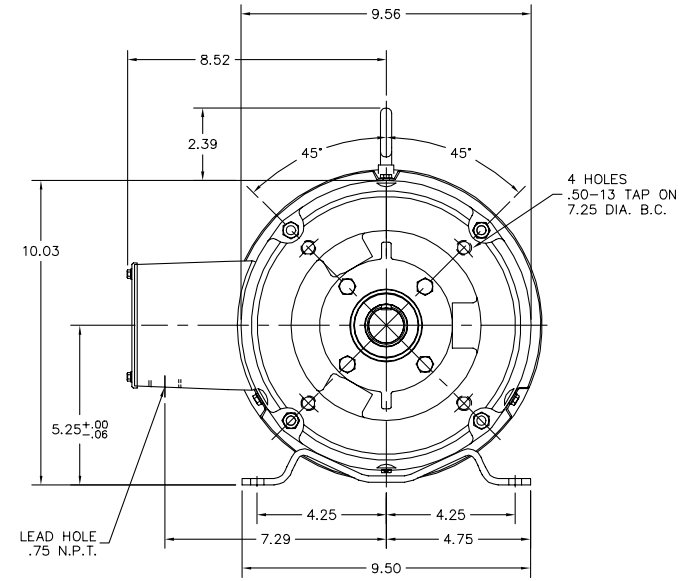
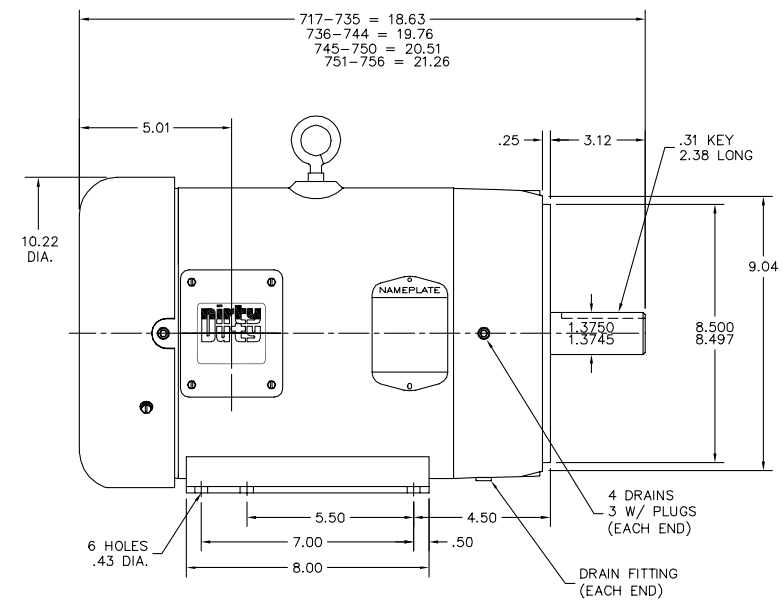

FRONT END DETAIL

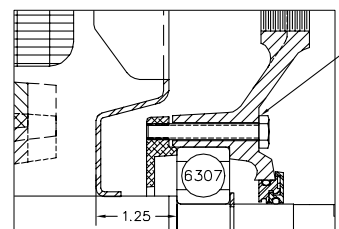

PULLEY END DETAIL

CUSTOMER IS RESPONSIBLE FOR DETERMINING THAT BALDOR'S PRODUCT WILL PERFORM SUITABLY IN THE INTENDED APPLICATION.

REV. DESC: NEW	VERSION: 00	TDR: 000000968673
REV. LTR: -	REVISED: 06:38:31 04/14/2016	BY: ENCHALO
FILE: \AAA\00226\145		
MTL: -		

BALDOR
 STD HORZ 213-5TC TEFC 37M DDP
 SH 1 of 1

37LYN854

CD0005



LOW VOLTAGE (2Y)



LINE

HIGH VOLTAGE (1Y)

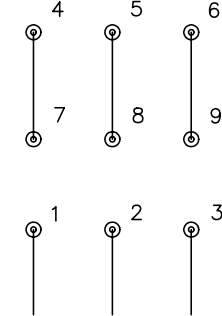

LINE

NOTES:

1. INTERCHANGE ANY TWO LINE LEADS TO REVERSE ROTATION.
2. OPTIONAL THERMOSTATS ARE PROVIDED WHEN SPECIFIED.
3. ACTUAL NUMBER OF INTERNAL PARALLEL CIRCUITS MAY BE A MULTIPLE OF THOSE SHOWN ABOVE.
4. LEAD COLORS ARE OPTIONAL. LEADS MUST ALWAYS BE NUMBERED AS SHOWN.

REV. DESC: REVISE TO SHOW OPTIONAL COLORS			
REV. LTR: E	BY: JLP	REVISED: 01/19/99 10:15	TDR: 0171435
90000		FILE: AAA00005140	MDL: -
		MTL: -	

BALDOR ELECTRIC Co.

3PH, DV, 9 LEADS

CD0005