

BALDOR® • RELIANCE 

Product Information Packet

CEM2549T-G

75HP,3535RPM,3PH,60HZ,364TSC,OPSB,F1

Part Detail							
Revision:	A	Status:	PRD/A	Change #:		Proprietary:	No
Type:	AC	Elec. Spec:	42WGX343	CD Diagram:	CD0180	Mfg Plant:	
Mech. Spec:		Layout:	42LY-000-037	Poles:	02	Created Date:	09-16-2020
Base:		Eff. Date:	11-11-2021	Leads:	9#6		

Specs			
Catalog Number:	CEM2549T-G	Heater Indicator:	No Heater
Enclosure:	OPSB	Insulation Class:	H
Frame:	364TSC	Inverter Code:	Inverter Duty
Frame Material:	Steel	IP Rating:	NONE
Output @ Frequency:	75.000 HP @ 60 HZ	KVA Code:	F
Synchronous Speed @ Frequency:	3600 RPM @ 60 HZ	Lifting Lugs:	Standard Lifting Lugs
Voltage @ Frequency:	230.0 V @ 60 HZ	Locked Bearing Indicator:	Locked Bearing
	460.0 V @ 60 HZ	Motor Lead Termination:	Flying Leads
Agency Approvals:	CSA	Motor Type:	4250M
	CSA EEV	Mounting Arrangement:	F1
	UR	Power Factor:	90
Auxillary Box:	No Auxillary Box	Product Family:	General Purpose
Auxillary Box Lead Termination:	None	Pulley Face Code:	C-Face
Base Indicator:	Rigid	Rodent Screen:	None
Bearing Grease Type:	Polyrex EM (-20F +300F)	Shaft Ground Indicator:	Shaft Grounding
Blower:	None	Shaft Rotation:	Reversible
Current @ Voltage:	168.000 A @ 230.0 V	Speed Code:	Single Speed
	84.000 A @ 460.0 V	Motor Standards:	NEMA

Design Code:	A	Starting Method:	Direct on line
Drip Cover:	No Drip Cover	Thermal Device - Bearing:	None
Duty Rating:	CONT	Thermal Device - Winding:	None
Electrically Isolated Bearing:	Not Electrically Isolated	Vibration Sensor Indicator:	No Vibration Sensor
Feedback Device:	NO FEEDBACK	Winding Thermal 1:	None
		Winding Thermal 2:	None

Nameplate NP3554LUA											
CAT.NO.	CEM2549T-G			P/N				ENCL	OPSB		
SPEC.	42-0000-0090		CC	010A		FRAME	364TSC		SER.NO.		
HP	75		CLASS	H		HZ	60				
RPM	3535		PH	3		DES	A				
VOLTS	230/460			CODE	F		ODE BRG	6311		DE BRG	6313
AMPS	168/84			USABLE AT 208V	182						
RATING	40C AMB-CONT			NEMA-NOM-EFF	93.6		GREASE	POLYREX EM			
PF	90		SER.F.	1.15		CT30-60(2:1)		VT3-60(20:1)			
USABLE AT	50HZ 60HP 190/380V 204/102A				SF1.0						
HTR-VOLTS			HTR-AMPS			MAX. SPACE HEATER TEMP.					

Parts List		
Part Number	Description	Quantity
SA386799	SA 42-0000-0090	1.000 EA
RA377106	RA 42-0000-0090	1.000 EA
LB1115N	LABEL,LIFTING DEVICE (ON ROLLS)	1.000 EA
LB1119N	WARNING LABEL	1.000 EA
LC0181	CONNECTION LABEL	1.000 EA
NP3554LUA	SS SUPER-E VPWM INV READY UL CSA-EEV PRE	1.000 EA
85XU0407S04	4X1/4 U DRIVE PIN STAINLESS	4.000 EA
MN416A01	TAG-INSTAL-MAINT no wire (2100/bx) 4/22	1.000 EA
HA6360	LIFTING LUG FOR 42 FRAME MOTORS.	2.000 EA
MJ1000A02	GREASE, MOBIL POLYREX EM - 124047	0.200 LB
HA3151A07	THRUBOLT STUD 1/2-13 X 20.000	4.000 EA
HW1001A50	LOCKWASHER 1/2, ZINC PLT.,.879 OD, .509 I	8.000 EA
XY5013A12	NUT,1/2-13,HEX,STEEL,ZINCPLATED	8.000 EA
42EP3200A01	FR ENDPLATE, MACH	1.000 EA
HW5100A13	W4627-047 WVY WSHER	1.000 EA
HA4051A00	PLASTIC CAP FOR GREASE FITTING	1.000 EA
HW4500A03	GREASE FITTING, .125 NPT 1610(ALEMITE) 8	1.000 EA
HW4500A20	1/8NPT SL PIPE PLUG	1.000 EA
42EP1400A01	PUEP MACH,	1.000 EA
10XN3816K52	3/8-16 X 3-1/4 HEX HEAD CAP SCREW GRD 5	4.000 EA
HW1001A38	LOCKWASHER 3/8, ZINC PLT .688 OD, .382 I	4.000 EA
HA4051A00	PLASTIC CAP FOR GREASE FITTING	1.000 EA
HW4500A03	GREASE FITTING, .125 NPT 1610(ALEMITE) 8	1.000 EA
HW4500A20	1/8NPT SL PIPE PLUG	1.000 EA

Parts List (continued)		
Part Number	Description	Quantity
10CB1000A390	CONDUIT BOX, MACH	1.000 EA
19XW3118A12	.31-18 X .75 HEX WASHER HEAD TAPTITE II	4.000 EA
HW1001A31	LOCKWASHER 5/16, ZINC PLT.591 OD, .319 I	4.000 EA
WD1000B53	TERMINAL BURNDY KPA34	1.000 EA
10XN5013K10	1/2-13 X .625 HEX HD, GRADE 5	1.000 EA
HA6017	CAST ADAPTER, 40,42 KOBX	1.000 EA
19XW3118A12	.31-18 X .75 HEX WASHER HEAD TAPTITE II	2.000 EA
HW1001A31	LOCKWASHER 5/16, ZINC PLT.591 OD, .319 I	2.000 EA
10CB1500	CONDUIT BOX LID, MACH	1.000 EA
10XN2520K16	1/4-20 X 1" HX HD SCRW GRADE 5, ZINC P	4.000 EA
HW1001A25	LOCKWASHER 1/4, ZINC PLT .493 OD, .255 I	4.000 EA
42AD2001C01	BAFFLE PLATE 42 OPEN, SLOTTED BAND MTRS	1.000 EA
42AD2001C01	BAFFLE PLATE 42 OPEN, SLOTTED BAND MTRS	1.000 EA
MG1000Y03	MUNSELL 2.53Y 6.70/ 4.60, GLOSS 20,	0.125 GA
40PA1000	PACKAGING GROUP	1.000 EA
HW2501H18	KEY, 1/2 SQ X 2.000	1.000 EA

AC Induction Motor Performance Data

Record # 69619

Typical performance - not guaranteed values

Winding: 42WGX343-R001		Type: 4250M		Enclosure: OPSB	
Nameplate Data			460 V, 60 Hz: High Voltage Connection		
Rated Output (HP)	75	Full Load Torque	112 LB-FT		
Volts	230/460	Start Configuration	direct on line		
Full Load Amps	168/84	Breakdown Torque	381 LB-FT		
R.P.M.	3535	Pull-up Torque	111 LB-FT		
Hz	60 Phase	3	Locked-rotor Torque	148 LB-FT	
NEMA Design Code	B KVA Code	F	Starting Current	509 A	
Service Factor (S.F.)	1.15	No-load Current	19.8 A		
NEMA Nom. Eff.	93.6	Power Factor	90	Line-line Res. @ 25°C	0.092782 Ω
Rating - Duty	40C AMB-CONT	Temp. Rise @ Rated Load	41°C		
S.F. Amps		Temp. Rise @ S.F. Load	52°C		
		Locked-rotor Power Factor	21.3		

Load Characteristics 460 V, 60 Hz, 75 HP

% of Rated Load	25	50	75	100	125	150	S.F.
Power Factor	67	84	89	90	90	89	90
Efficiency	92.4	94.5	94.5	93.8	92.8	91.5	93.2
Speed	3584.7	3571.7	3556.4	3538.6	3518	3495.6	3526
Line amperes	28.3	44.4	63	83.9	106	130	97.2

Performance Graph at 460V, 60Hz, 75.0HP Typical performance - Not guaranteed values

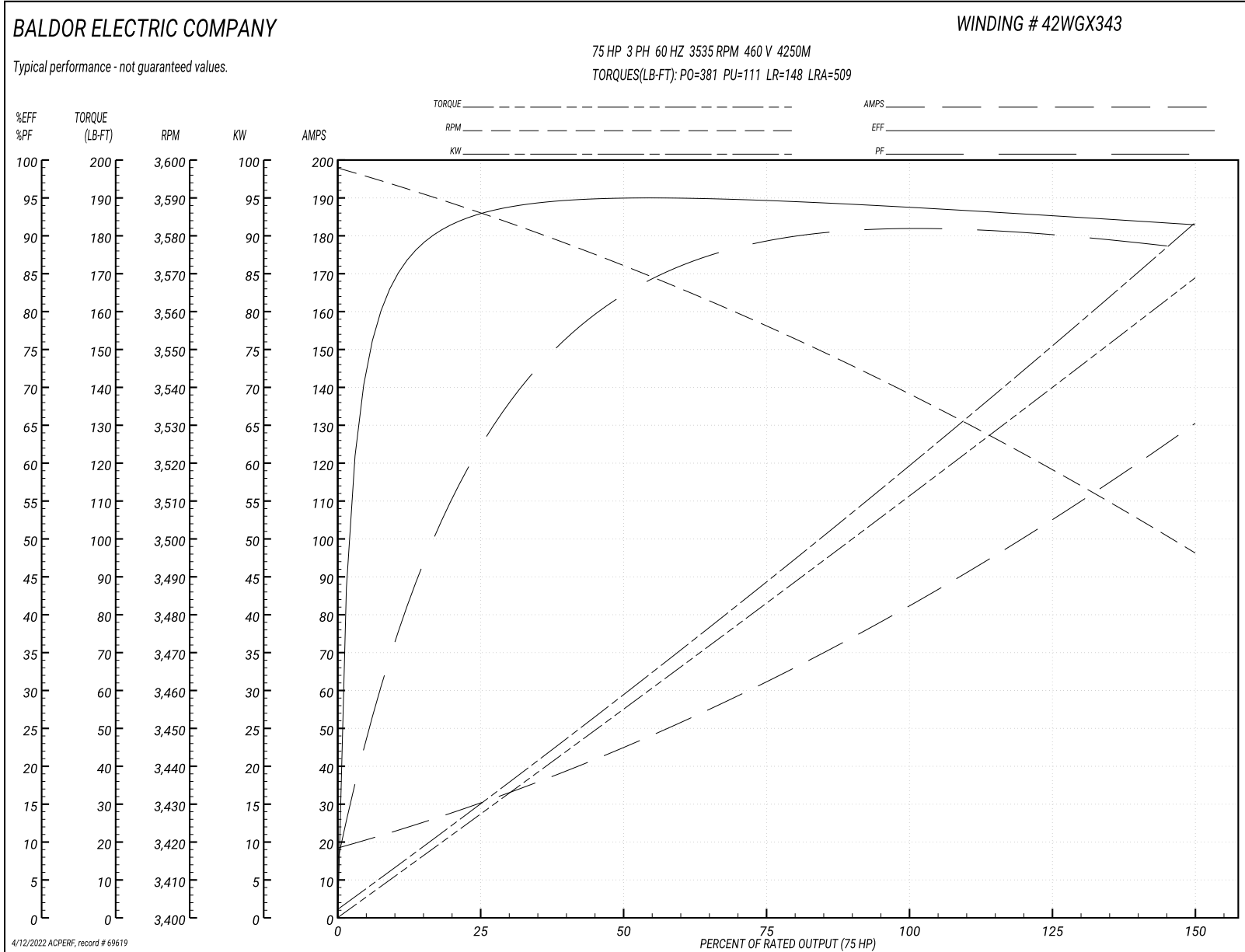

42LY-000-037

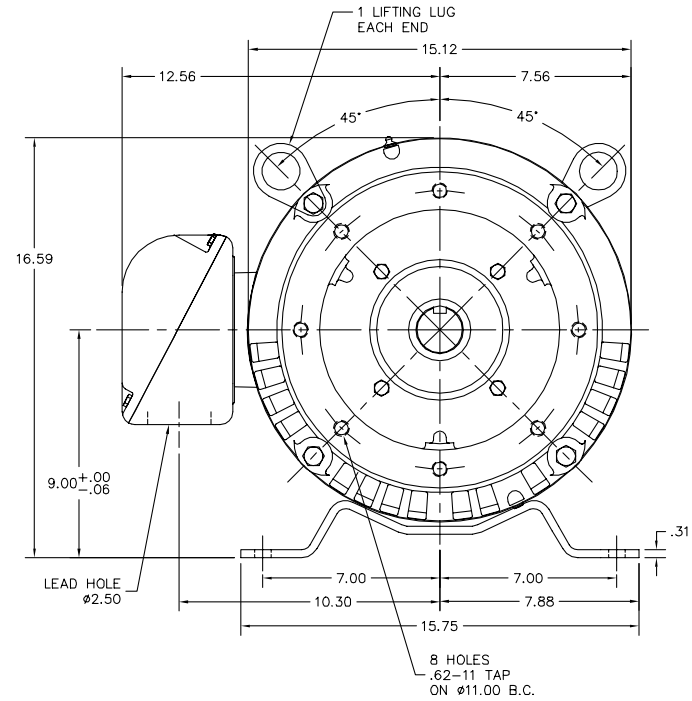
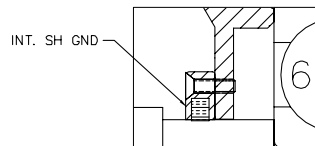
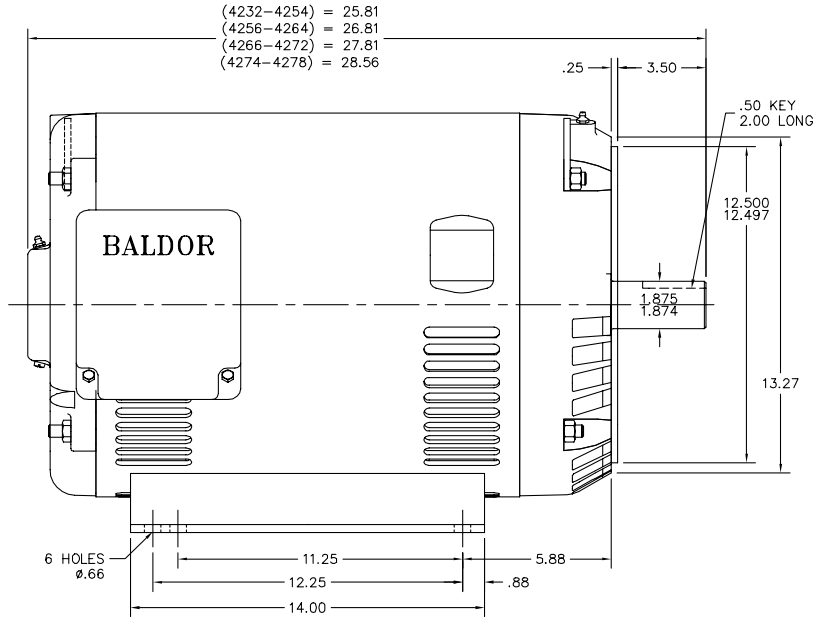

42LY-000-037

CUSTOMER IS RESPONSIBLE FOR DETERMINING THAT THE PRODUCT WILL PERFORM SUITABLY IN THE INTENDED APPLICATION.

REV. DESC: REMOVED LEADERS FOR GRSR & RELIEF	VERSION: 01	TDR: 000001181744
REV. LTR: A	REVISED: 02:17:44 11/22/2021	BY: USSADEL11
FILE: \AAA\00255\916		
MTL: -		

BALDOR - RELIANCE®
 HOR OPSB 364-5TSC W/CI KOBX, INT SH GND
 SH 1 of 1

CD0180

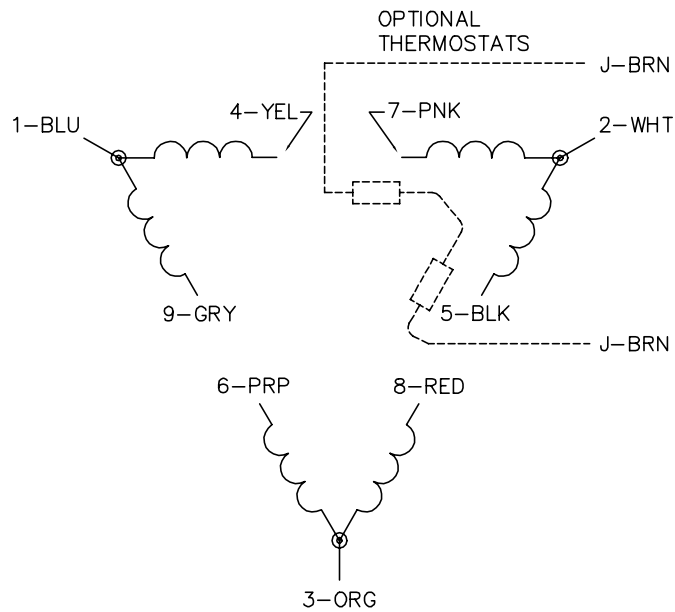

LOW VOLTAGE
(2D)



HIGH VOLTAGE
(1D)



NOTES:

1. INTERCHANGE ANY TWO LINE LEADS TO REVERSE ROTATION.
2. OPTIONAL THERMOSTATS ARE PROVIDED WHEN SPECIFIED.
3. ACTUAL NUMBER OF INTERNAL PARALLEL CIRCUITS MAY BE A MULTIPLE OF THOSE SHOWN ABOVE.
4. LEAD COLORS ARE OPTIONAL. LEADS MUST ALWAYS BE NUMBERED AS SHOWN.

CD0180

REV. DESC: ADD CLASS CONN00000007		
REV. LTR: D	VERSION: 01	TDR: 000001099922
FILE: \AAA\00005\148	REVISED: 10:25:29 02/19/2019	BY: ENBRIRO
MTL: -	© □	

BALDOR - RELIANCE®

3PH, DV, 9 LEADS, DELTA CONNECTION

SH 1 of 1

Marketing maintained PDF of MN416:

<http://www.baldor.com/support/Literature/Load.ashx/MN416?ManNumber=MN416>