

BALDOR® • RELIANCE 

Product Information Packet

CEM3614T-G

2HP, 1175RPM, 3PH, 60HZ, 184TC, TEFC, F1

Part Detail							
Revision:	A	Status:	PRD/A	Change #:		Proprietary:	No
Type:	AC	Elec. Spec:	36WGR104	CD Diagram:	CD0005	Mfg Plant:	
Mech. Spec:		Layout:	36LYN147	Poles:	06	Created Date:	12-17-2019
Base:		Eff. Date:	11-11-2021	Leads:	9#16		

Specs			
Catalog Number:	CEM3614T-G	Feedback Device:	NO FEEDBACK
Enclosure:	TEFC	Heater Indicator:	No Heater
Frame:	184TC	Insulation Class:	H
Frame Material:	Steel	Inverter Code:	Inverter Ready
Output @ Frequency:	2.000 HP @ 60 HZ	IP Rating:	NONE
Synchronous Speed @ Frequency:	1200 RPM @ 60 HZ	KVA Code:	L
Voltage @ Frequency:	460.0 V @ 60 HZ	Lifting Lugs:	Standard Lifting Lugs
	230.0 V @ 60 HZ	Locked Bearing Indicator:	Locked Bearing
XP Class and Group:	None	Motor Lead Termination:	Flying Leads
XP Division:	Not Applicable	Motor Type:	3644M
Agency Approvals:	CSA	Mounting Arrangement:	F1
	CSA EEV	Power Factor:	66
	UR	Product Family:	General Purpose
Auxillary Box:	No Auxillary Box	Pulley Face Code:	C-Face
Auxillary Box Lead Termination:	None	Rodent Screen:	None
Base Indicator:	Rigid	Shaft Ground Indicator:	Shaft Grounding
Bearing Grease Type:	Polyrex EM (-20F +300F)	Shaft Rotation:	Reversible
Blower:	None	Speed Code:	Single Speed

Current @ Voltage:	3.200 A @ 460.0 V	Motor Standards:	NEMA
	6.400 A @ 230.0 V	Starting Method:	Direct on line
Design Code:	B	Thermal Device - Bearing:	None
Drip Cover:	No Drip Cover	Thermal Device - Winding:	None
Duty Rating:	CONT	Vibration Sensor Indicator:	No Vibration Sensor
Electrically Isolated Bearing:	Not Electrically Isolated	Winding Thermal 1:	None
		Winding Thermal 2:	None

Nameplate NP3441LUA										
CAT.NO.	CEM3614T-G									
SPEC	36-0000-0253									
HP	2									
VOLTS	230/460									
AMPS	6.4/3.2									
RPM	1175									
FRAME	184TC				HZ	60			PH	3
SF	1.15		CODE	L	DES	B		CLASS	H	
NEMA NOM. EFF	88.5		PF	66						
RATING	40C AMB-CONT									
CC	010A				USABLE AT 208V					6.6
ENCL	TEFC		SER							
DE	6206			ODE	6205					
VPWM INVERTER READY										
CT6-60H(10:1)VT3-60H(20:1										
	50HZ 2HP 190/380V 7.4/3.7A									
	SF1.0									

Parts List		
Part Number	Description	Quantity
SA377290	SA 36-0000-0253	1.000 EA
RA367205	RA 36-0000-0253	1.000 EA
LB1115N	LABEL,LIFTING DEVICE (ON ROLLS)	1.000 EA
LC0005E01	CONN.DIA./WARNING LABEL (LC0005/LB1119N)	1.000 EA
NP3441LUA	ALUM SUPER-E VPWM INV READY UL CSA-EEV C	1.000 EA
85XU0407S04	4X1/4 U DRIVE PIN STAINLESS	2.000 EA
MN416A01	TAG-INSTAL-MAINT no wire (2100/bx) 4/22	1.000 EA
HW3200A01	3/8-16X3/4 I-BLT WELDED F/S	1.000 EA
36FH4009A102	IEC FH GREASER PRIMED	1.000 EA
51XW1032A06	10-32 X .38, TAPTITE II, HEX WSHR SLTD S	3.000 EA
36FN3000C01SP	EXFN, PLASTIC, 5.25 OD, .912 ID	1.000 EA
51XB1214A16	12-14X1.00 HXWSSLD SERTYB	1.000 EA
MJ1000A02	GREASE, MOBIL POLYREX EM - 124047	0.050 LB
HA3101A28	THRUBOLT 1/4-20 X 12.500 OHIO ROD	4.000 EA
LB1459	AEGIS SGR LABEL "AEGISLBL-100"	1.000 EA
36EP3104A01	FREP MACH W/GRSR, RAISED FH PADS	1.000 EA
HW5100A05	WVY WSHR F/205 & 304 BRGS	1.000 EA
HW4500A01	1641B(ALEMITE)400 UNIV, GREASE FITT	1.000 EA
36EP3301A23	PU ENDPLATE, ENCL. 182-4TC 206 BRG. W/GR	1.000 EA
10XN2520A28	1/4-20X 1 3/4 HEX HD	4.000 EA
HW1001A25	LOCKWASHER 1/4, ZINC PLT .493 OD, .255 I	4.000 EA
HW4500A01	1641B(ALEMITE)400 UNIV, GREASE FITT	1.000 EA
BP5310A02	AEGIS SH GRD ASSY W/RETAINER RING	1.000 EA
36CB3004	36 CB CASTING W/1.09 DIA LEAD HOLE @ 6:0	1.000 EA

Parts List (continued)		
Part Number	Description	Quantity
FE-0000001	ZRTG FE ASSEMBLY	1.000 EA
36GS1000SP	GASKET-CONDUIT BOX, .06 THICK #SV-330 LE	1.000 EA
PE-0000001	ZRTG PE ASSEMBLY	1.000 EA
51XB1016A08	10-16X 1/2HXWSSLD SERTYB	2.000 EA
HW3001B02	BRASS CUP WASHER W/GROUND SYMBOL TAB,	1.000 EA
11XW1032G06	10-32 X .38, TAPTITE II, HEX WSHR SLTD U	1.000 EA
36CB4516	750LIPPED CB LID - GALVANNEAL	1.000 EA
37GS1001	GASKET, CONDUIT BOX LID, .06 THICK LEXID	1.000 EA
51XW0832A07	8-32 X .44, TAPTITE II, HEX WSHR SLTD SE	4.000 EA
MG1000Y03	MUNSELL 2.53Y 6.70/ 4.60, GLOSS 20,	0.022 GA
G0PA1000	PKG GRP, PRINT PK1026A06	1.000 EA
HW2501E19	STD SQUARE KEY .25 SQUARE X 2.125 LONG	1.000 EA
HA7000A02	KEY RETAINER RING, 1 1/8 DIA, 1 3/8 DIA	1.000 EA

AC Induction Motor Performance Data

Record # 80304

Typical performance - not guaranteed values

Winding: 36WGR104-R009		Type: 3644M		Enclosure: TEFC	
Nameplate Data			460 V, 60 Hz: High Voltage Connection		
Rated Output (HP)	2	Full Load Torque	8.95 LB-FT		
Volts	230/460	Start Configuration	direct on line		
Full Load Amps	6.4/3.2	Breakdown Torque	33.6 LB-FT		
R.P.M.	1175	Pull-up Torque	17.9 LB-FT		
Hz	60 Phase	3	Locked-rotor Torque	23.4 LB-FT	
NEMA Design Code	B KVA Code	L	Starting Current	23 A	
Service Factor (S.F.)	1.15	No-load Current	2.01 A		
NEMA Nom. Eff.	88.5	Power Factor	66	Line-line Res. @ 25°C	4.95 Ω
Rating - Duty	40C AMB-CONT		Temp. Rise @ Rated Load	34°C	
S.F. Amps			Temp. Rise @ S.F. Load	41°C	
			Locked-rotor Power Factor	28.9	
			Rotor inertia	0.413 LB-FT ²	

Load Characteristics 460 V, 60 Hz, 2 HP

% of Rated Load	25	50	75	100	125	150	S.F.
Power Factor	28	46	57	66	70	73	68
Efficiency	79	86.6	88.4	88.9	88.9	87.3	88.9
Speed	1196	1189	1182	1175	1167	1157	1170
Line amperes	2.11	2.38	2.76	3.21	3.75	4.38	3.53

Performance Graph at 460V, 60Hz, 2.0HP Typical performance - Not guaranteed values

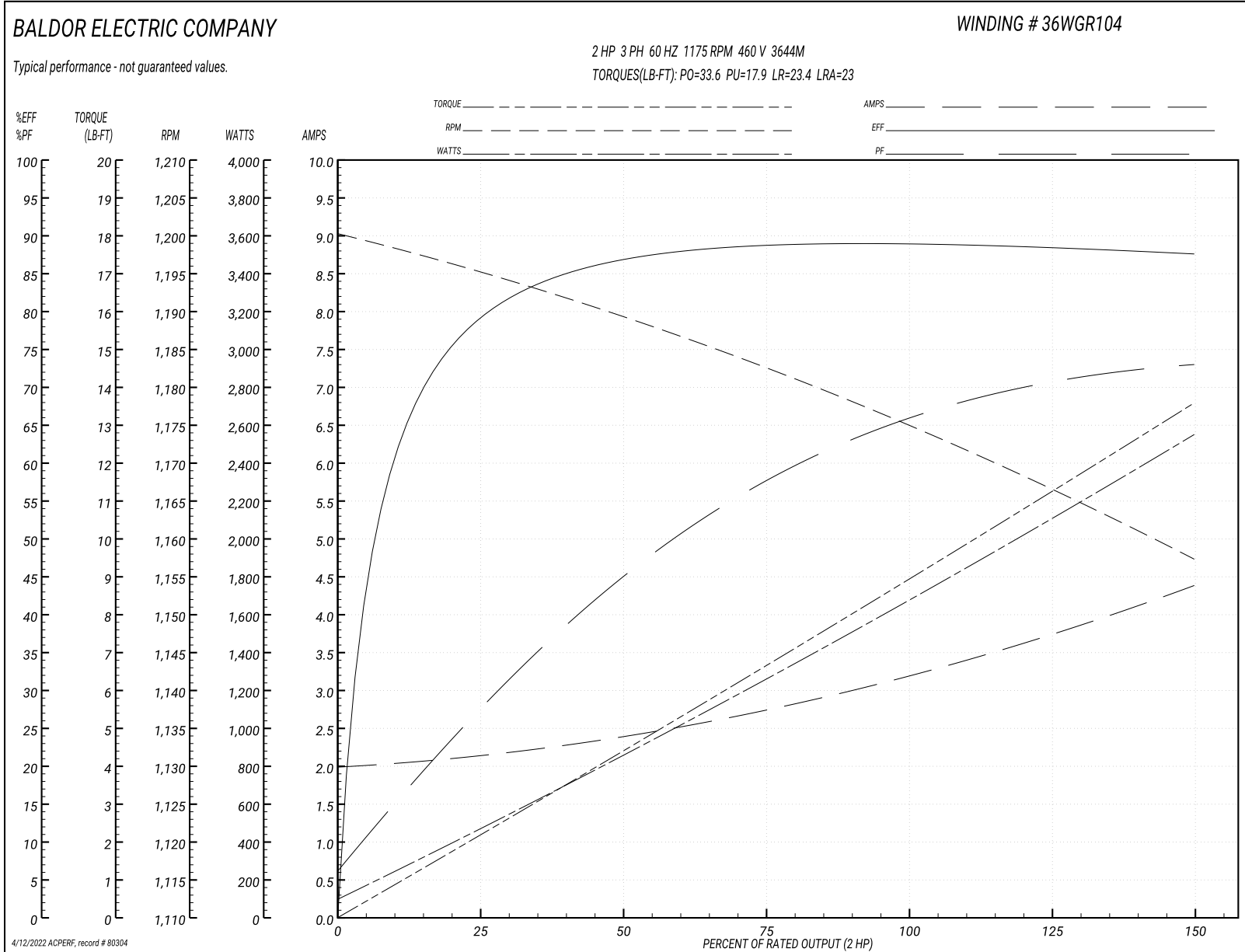

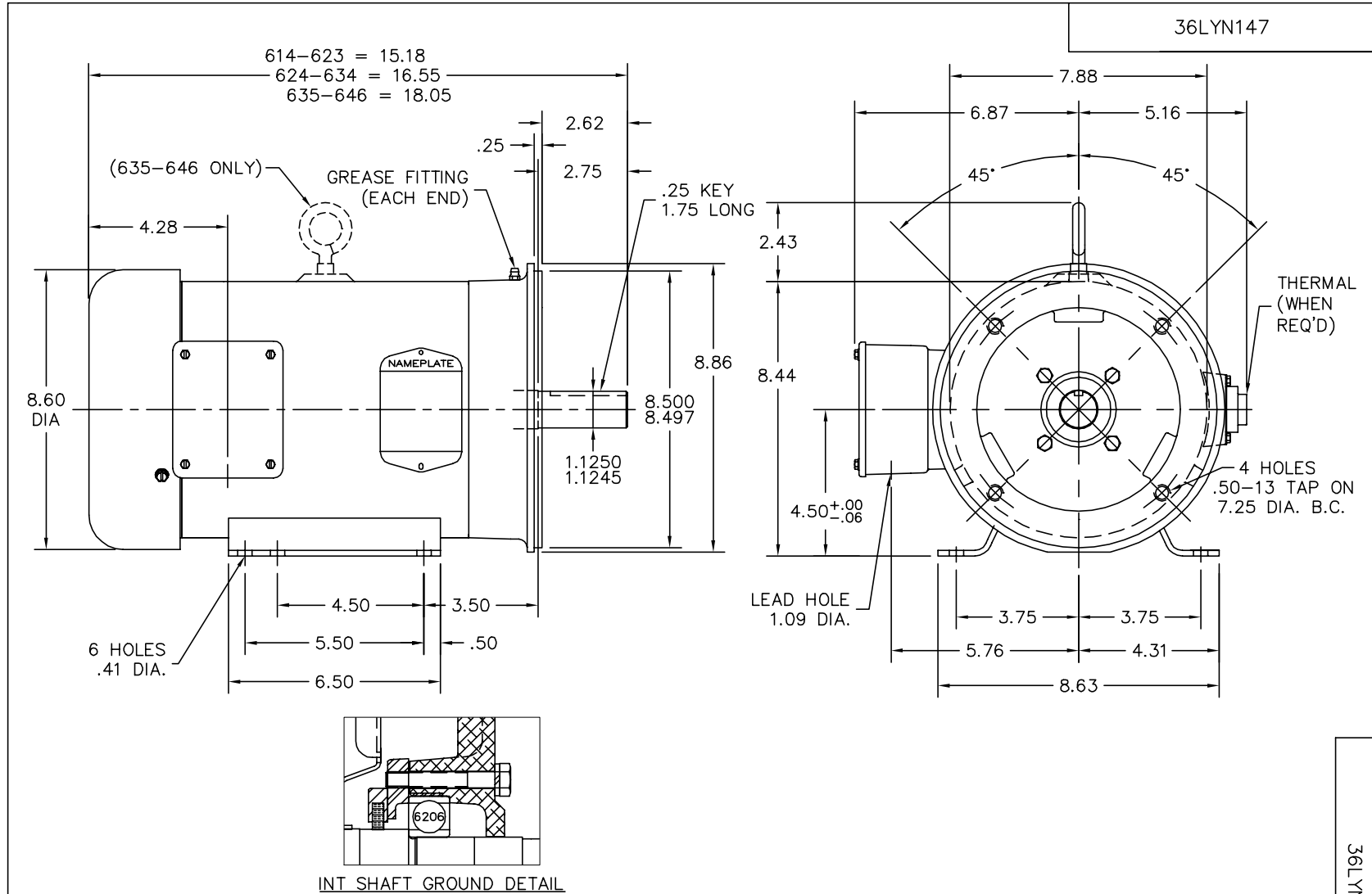

CUSTOMER IS RESPONSIBLE FOR DETERMINING THAT BALDOR'S PRODUCT WILL PERFORM SUITABLY IN THE INTENDED APPLICATION.

REV. DESC: CHG RET RING		
REV. LTR: A	VERSION: 01	TDR: 000000582987
FILE: \AAA\00174\176	REVISED: 10:23:06 03/05/2011	
MTL: -	BY: ENWINBO	

BALDOR

HORZ FACE MTD 182-4TC TEFC 36M W/INT SH GND (AEGIS)

SH 1 of 1

36LYN147

CD0005



LOW VOLTAGE
(2Y)



LINE

HIGH VOLTAGE
(1Y)

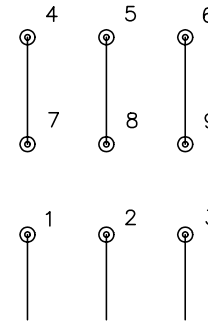

LINE

NOTES:

1. INTERCHANGE ANY TWO LINE LEADS TO REVERSE ROTATION.
2. OPTIONAL THERMOSTATS ARE PROVIDED WHEN SPECIFIED.
3. ACTUAL NUMBER OF INTERNAL PARALLEL CIRCUITS MAY BE A MULTIPLE OF THOSE SHOWN ABOVE.
4. LEAD COLORS ARE OPTIONAL. LEADS MUST ALWAYS BE NUMBERED AS SHOWN.

REV. DESC: REVISE TO SHOW OPTIONAL COLORS			
REV. LTR: E	BY: JLP	REVISED: 01/19/99 10:15	TDR: 0171435
90000		FILE: AAA00005140	MDL: -
		MTL: -	

BALDOR ELECTRIC Co.

3PH, DV, 9 LEADS

CD0005

Marketing maintained PDF of MN416:

<http://www.baldor.com/support/Literature/Load.ashx/MN416?ManNumber=MN416>